

# Ingersoll-Rand®

## Winches and High Capacity Hoists



# Winches and High Capacity Hoists

## Table of Contents



This catalog presents the products of the Winch and High Capacity Hoist business segment of IR.

By providing more focused attention to our products and their related markets, the improvements in these products, processes and services will continue to drive our pursuit of excellence. Our belief is that customers will respond by making IR their supplier and partner of choice.

These winch and hoist products are sold and serviced by a network of distributors around the world. We appreciate the opportunity to meet your material handling product needs.

### 1. Electric Winches

#### Electric Worm Gear Series

1500 and 2000 lb (682 and 909 kg) capacity ..... 2

#### Electric Winches and Car Pullers

200 to 25000 lb (91 to 11364 kg) capacity ..... 3

#### Fulcrum Winches

5300 to 50000 lb (2409 to 22680 kg) capacity ..... 7

### 2. Air Winches

Selection Guide ..... 12

#### Classic Air Winch Series

1000 and 2000 lb (454 and 909 kg) capacity ..... 15

#### Liftstar™ and Pullstar™ Gear Motor Series

330 to 22000 lb (150 to 10000 kg) capacity ..... 17

#### FA2B “Third Generation” Air Winch Series

4000 lb (1818 kg) capacity ..... 21

#### FA2.5A/FA5A “Third Generation” Air Winch Series

5000 to 10000 lb (1818 to 2273 kg) capacity ..... 24

#### Force 5™ Air Winch Series

4400 to 22000 lb (2000 to 10000 kg) capacity ..... 27

#### Force 5™ “Guideline and Podline” Series

3400 and 10200 lb (1545 and 4636 kg) capacity ..... 35

Accu-Spool™ Level Wind ..... 36

#### Force 5™ “Offshore” Man Rider™ Series

330 to 6870 lb (150 to 3117 kg) capacity  
meets ABS, DNV and LRS and CE requirements ..... 37

#### “Third Generation” “Offshore” Gulf Man Rider™

2500 lb (1136 kg) capacity ..... 42

#### Liftstar “Offshore” Man Rider™ Series

330 to 2200 lb (150 to 1000 kg) capacity ..... 43

#### Force 5™ “Onshore” Man Rider™ Series

2200 and 4400 lb (1000 and 2000 kg) capacity  
meets ANSI-ASME A10.22-1990 ..... 46

### 3. Natural Gas Powered Winches

1000 to 10000 lb (455 to 4545 kg) capacity ..... 49

### 4. Hydraulic Winches

1000 to 100000 lb (455 to 45450 kg) capacity ..... 50

### 5. High Capacity Chain Hoists

#### Hercu-Link™ Air Chain Hoist

5 to 100 metric ton capacity ..... 53

#### Liftchain LCA Lube Free Hoist Series

1.5 to 100 metric ton capacity ..... 59

#### Hercu-Link™ Electric Chain Hoist

5 to 50 metric ton capacity ..... 68

### 6. Trolleys and Accessories

#### Man Rider™ Plain and Brake

1.5 to 6 metric ton capacity ..... 74

#### Man Rider™ Piston Motor Driven and 4-Wheel Drive

1.5 to 6 metric ton capacity ..... 75

Winch Construction Cages ..... 76

Accu-Trol™ Pneumatic Pendant Control ..... 77

Electric-Over-Air Pendant Control ..... 78

Air line accessories ..... 79

### 7. Tech Tips

Drum calculation program ..... 80

Fleet angle, stall & line pull info, wire rope guide ..... 81

S•COR•E information ..... 82

I-Beam Specifications ..... 83

English to metric conversion chart ..... 84

Winch Check List ..... 85

Hoist Check List ..... 86

Notes ..... 87

### 8. Hoist and Winch Limited Warranty ..... 89



FM 53539



## Electric Winches

*The IR line of electric winches incorporates over 70 years of experience in solving the most challenging lifting, pulling and positioning applications in the world's toughest industries.*

### *Why choose an IR electric winch?*

- The high quality components in an IR electric winch deliver reliable performance and long lasting service.
- IR electric winches are designed to offer maximum environmental resistance.
- Each IR winch is provided with a totally enclosed fan cooled motor.
- The motor design of each IR winch incorporates class "B" electrical insulation with a minimum 1.0 service factor that ensures the motor's ability to deliver 100% of its rated horsepower throughout the duty cycle of that motor.
- The automatic braking system delivers positive load control for lifting and lowering.
- IR electric winches incorporate a flexible design that allows for horizontal, vertical or upside down positioning.

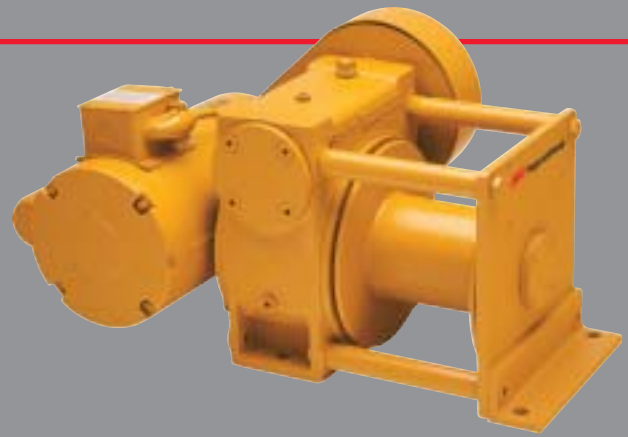

# Electric Worm Gear Series

## 1500 and 2000 lb (682 and 909 kg) capacity



### Standard features:

- Fully reversing, totally enclosed, non-ventilated (TENV) motors; 15 minute duty cycle for EBT1500; 10 for EBT2000
- Spring set, electromagnetically released automatic shoe style brake with manual release for emergency operation
- Bronze worm gear provides automatic self-locking for extra safety
- Fully enclosed anti-friction bearings
- Hand crank for emergency manual operation

- Aluminum frame and drum
- Belt driven

### Options:

- Control package:
  - NEMA 4, watertight enclosure
  - NEMA 4, magnetic reversing starters
  - NEMA 3R or 4, pushbutton controls
  - NEMA 1 or 4, reversing drum switch
- Single or three phase motors
- 12" (305 mm) drum
- Free spool feature
- Chain drive
- Electronic overload protection



EBT2000B20-5

### Specifications

Model no.	Line pull 2nd layer		Line speed 2nd layer		Duty cycle min	hp	Maximum drum storage for rope diameter of								Shipping weight	
	lbs	kg	fpm	m/min			ft	3/16" m	1/4" m	5/16" m	3/8" m	lbs	kg			
EBT1500A20-5	1500	682	20	6	15	1 1/2	338	103	200	61	122	37	87	27	129	59
EBT1500A20-12	1500	682	20	6	15	1 1/2	811	247	600	183	292	89	208	63	145	66
EBT2000B20-5	2000	909	20	6	10	1 1/2	338	103	200	61	122	37	87	27	129	59
EBT2000B20-12	2000	909	20	6	10	1 1/2	811	247	600	83	292	89	208	63	145	66

Notes: For three phase, replace "A" (single) in model number with the letter "B". EBT2000 not available in single phase. A=115/230-1-60, B=230/460-3-60, re-connectable dual voltage. Amp draw at 230v: EBT1500A = 10.5 amps; EBT2000B = 5.0 amps

### Line pull / lifting capacity at various rope layers

3/16" (5 mm) wire rope; maximum number of layers: 10

Model number	Cap. layer no. 5 (mid-layer)		Cap. layer no. 10	
	lbs	kg	lbs	kg
EBT1500A20-*	1200	545	900	409
EBT2000B20-*	1600	727	1210	550

1/4" (6 mm) wire rope; maximum number of layers: 10

Model number	Cap. layer no. 3 (mid-layer)		Cap. layer no. 6	
	lbs	kg	lbs	kg
EBT1500A20-*	1140	518	810	368
EBT2000B20-*	1520	691	1080	491

5/16" (8 mm) wire rope; maximum number of layers: 6

Model number	Cap. layer no. 3 (mid-layer)		Cap. layer no. 6	
	lbs	kg	lbs	kg
EBT1500A20-*	1330	605	1000	455
EBT2000B20-*	1780	809	1330	605

3/8" (10 mm) wire rope; maximum number of layers: 5

Model number	Cap. layer no. 3 (mid-layer)		Cap. layer no. 6	
	lbs	kg	lbs	kg
EBT1500A20-*	1310	595	1040	473
EBT2000B20-*	1740	791	1390	632

### Dimensions

Model	Drum length A		B		C		D	
	in.	mm	in.	mm	in.	mm	in.	mm
EBT1500A20-5	5	127	4.38	111	9.44	240	13.63	346
EBT1500A20-12	12	305	7.88	200	16.44	418	20.63	524
EBT2000B20-5	5	127	4.25	108	9.44	240	21.75	552
EBT2000B20-12	12	305	7.75	197	16.44	418	28.75	730

Dimensions are subject to change. Contact factory for certified prints.

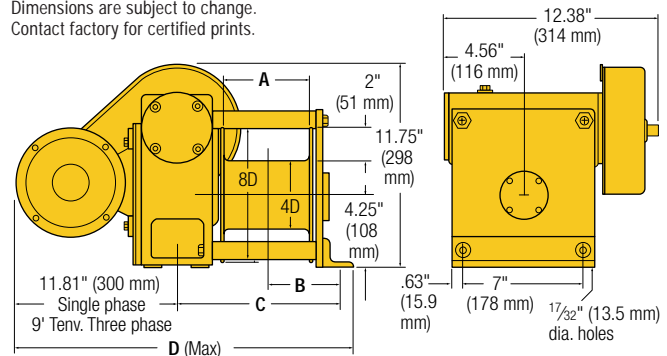

### How to Order:

Complete the model below by adding the appropriate code for the desired voltage. Add option codes as required. Example: EBT1500B20-5-4C

Series	Line pull 2nd layer (lbs)	Model single/three phase	Line speed 2nd layer (fpm)	Drum length (inches)	Voltage	Options (all factory installed)
EBT	1500	B	20	5	4	C
EBT	1500	A = Single phase		5 = 5 inches (127 mm)	1 = 115V	C = Free spool <sup>2</sup>
	2000	B = Three phase		12 = 12 inches (305 mm)	2 = 230V	D1 = NEMA 1 drum switch
					3 = 380V	D4 = NEMA 4 drum switch
					4 = 460V	Q = Special paint; please specify
					5 = 575V	R = Chain drive
						S = Rotary limit switch <sup>2</sup>
						Y = Electronic overload <sup>1</sup>

Note: Magnetic reversing starter and pushbutton controls are sold separately.  
 1 Requires the purchase of a magnetic reversing starter (see control options)  
 2 Mutually exclusive-cannot provide both (C & S) options on same winch.

# Electric Winches and Car Pullers

## 200 to 25000 lb (91 to 11364 kg) capacity



**IR electric winches and car pullers offer maximum performance and reliability.**

**Standard features:**

- Totally enclosed fan cooled (TEFC) motors are high torque design, Nema "B" class with an average of 280 percent starting torque. Rated for continuous duty.
- Winches utilize an automatic disc brake rated at 200% motor torque
- Structural steel frames allow flexibility in installation
- Car pullers have a lever operated, jaw clutch that allows for:
  - disengagement of the drum for free spooling of wire rope
  - bi-directional rail car pulling
- Car pullers have an adjustable drag brake to control drum spinning and cable over-run during free spooling operation

**Options:**

- Available in single or three phase motors (single phase through 3hp only)
- IEEE 45 marine grade motor (three phase only) and gear box available (specify by adding **M** to model; see **How to Order** information)
  - Three phase marine grade winch motors have a corrosion-resistant coating on motor windings to prevent corrosion due to condensation
  - Marine grade gear-boxes incorporate bronze filters and breather cover caps
- Longer or shorter drum sizes
- Drum divider flange and extra cable anchors
- Grooved drums



6000B20  
Electric Winch

- Control packages consisting of:
  - NEMA 4 magnetic reversing starters (single and three phase)
  - NEMA 4 wall-mount pushbutton stations
  - NEMA 3R or NEMA 4 hand-held pushbutton pendants
  - NEMA 1 or NEMA 4 reversing drum switches (through 2hp only)
- Sandblast/carbozinc primer with a Marine 812 finish
- Heaters (in motor windings)
- Limit switch; 2 position; upper and lower; NEMA 4 class enclosure
- Adjustable torque limiting clutch
- Disengaging clutch
- Horizontal Load Reversing (HLR) designs for load movement in two directions. Includes grooved drum, two wire rope anchors and a drum length to spool all wire rope on the first layer
- Explosion-proof components
- Design and manufacturing expertise for special applications

### Specifications

Model single/ three phase	Rated capacity at 2nd layer <sup>(1)</sup>		Appx line spd/min			Starting line pull				Running line pull				Rec'd wire rope in. mm	Drum capacity <sup>(2)</sup>		Shipping weight				
	lbs	kg	ft	m	hp	1st layer lbs	kg	4th layer lbs	kg	1st layer lbs	kg	4th layer lbs	kg		2nd layer ft	m	full drum ft	m	lbs	kg	
200A40/B40	200	91	40	12.2	1/3	550	280	438	199	220	100	175	80	1/4	6	81	25	288	88	160	73
250A40/B40	250	114	20	6.1	1/4	688	313	538	245	275	125	215	98	1/4	6	81	25	288	88	160	73
500A20/B20	500	227	20	6.1	1/2	1375	625	1075	489	550	250	430	195	1/4	6	81	25	288	88	160	72
500A40/B40	500	227	40	12.2	3/4	1375	625	1075	489	550	250	430	195	1/4	6	81	25	288	88	160	72
700A40/B40	700	318	40	12.2	1	1938	881	1525	693	775	352	610	277	1/4	6	81	25	288	88	150	68
800A20/B20	800	364	20	6.1	2	2200	1000	1750	795	880	400	700	318	1/4	6	81	25	288	88	190	86
1300A20*/B20* <sup>(3)</sup>	1300	591	20	6.1	1	3240	1473	2550	1159	1410	641	1110	505	5/16	8	120	37	605	184	370	168
1400A40*/B40* <sup>(3)</sup>	1400	636	40	12.2	2	3540	1609	2780	1264	1540	700	1210	550	5/16	8	120	37	605	184	370	168
1600B90	1600	727	90	27.4	5	4400	2000	3350	1523	1760	800	1340	609	3/8	10	105	32	460	140	625	283
2000A20*/B20* <sup>(3)</sup>	2000	909	20	6.1	1 1/2	4950	2250	3750	1705	2150	977	1675	761	3/8	10	105	32	460	140	375	170
2000A40*/B40* <sup>(3)</sup>	2000	909	40	12.2	3	4970	2259	3770	1714	2160	982	1675	761	3/8	10	105	32	460	140	445	202
2000B60	2000	909	60	19.3	5	5400	2455	4175	1898	2160	982	1670	759	3/8	10	105	32	460	140	575	261
3000B40* <sup>(3)</sup>	3000	1364	40	12.2	5	7600	3455	5900	2682	3300	1500	2560	1164	7/16	12	119	36	422	129	575	261
3500B80	3500	1591	80	24.4	12	9450	4295	7450	3386	3780	1718	2980	1355	7/16	12	125	38	875	267	690	313
4000A20*/B20* <sup>(3)</sup>	4000	1818	20	6.1	3	9700	4409	7270	3305	4220	1918	3160	1436	1/2	13	107	33	309	94	525	239
4500B50* <sup>(3)</sup>	4500	2045	50	15.2	7 1/2	11200	5091	8450	3841	4840	2200	3680	1673	1/2	13	107	33	309	94	630	286
6000B20* <sup>(3)</sup>	6000	2727	20	6.1	5	15400	7000	11600	5273	6700	3045	5040	2291	5/8	16	146	45	422	129	930	422
6000B40* <sup>(3)</sup>	6000	2727	40	12.2	7 1/2	17200	7818	12950	5886	7480	3400	5630	2559	5/8	16	146	45	422	129	950	431
10000B20*	10000	4545	20	6.1	7 1/2	29670	13486	22200	10091	12900	5864	9650	4386	3/4	19	146	45	323	98	1525	692
10000B40* <sup>(3)</sup>	10000	4545	40	12.2	15	27150	12341	20350	9250	11800	5364	8850	4023	3/4	19	146	45	323	98	1740	789
15000B20* <sup>(3)</sup>	15000	6818	20	6.1	12	37500	17045	30000	13636	17200	7818	13000	5909	1	25	230	70	600	183	2750	1247
25000B25* <sup>(3)</sup>	25000	11363	25	7.6	20	62800	28545	48300	21955	27300	12409	21000	9545	1 1/4	32	240	73	860	262	3550	1614

\*Chain drive from motor drum. Design factor 6:1 or more on chain at rated line pulls.

(1) Capacities rated at specified voltage with single line on second layer on drum, providing 5:1 design factor. Starting line pulls for reference only.

(2) Drum capacities shown represent tightly spooled wire rope. Recommended drum working capacity is 80% of value shown.

(3) Also available as car puller models. Add **CP** to model number when ordering. Example: **CP1300B20**

**Dimensions**

Model Single	Three phase	Dimensions in inches																
		A	B	C	D	E	F	H	J	K	L	M	N	O	P	Q	R	R <sub>1</sub>
200A40	200B40	1.75	8	8	4.50	18	13.50	15.50	6	5.75	7.50	7.50	20	13.63	1	1	-	-
250A20	250B20	1.75	8	8	4.50	8	13.50	15.50	6	5.75	7.50	7.50	20	13.63	1	1	-	-
500A20	500B20	1.75	8	8	4.50	18	13.50	15.50	6	5.75	9.31	7.50	20	14.63	1	1	-	-
500A40	500B40	1.75	8	8	4.50	18	13.50	15.50	6	5.75	9.31	7.50	20	14.63	1	1	-	-
700A40	700B40	1.75	8	8	4.50	18	13.50	15.50	6	5.75	9.31	7.50	20	14.63	1	1	-	-
800A20	800B20	1.75	8	8	4.50	18	13.50	15.50	6	5.75	9.31	7.50	20	14.63	1	1	-	-
1300A20	1300B20	2.69	12	12	6.63	12.63	18.50	20	8	9	5	9.50	27.25	16.75	1	0.75	44	2.50
1400A40	1400B40	2.69	12	12	6.63	12.63	18.50	20	8	9	8	9.50	27.25	16.75	1	0.75	44	2.50
	1600B90	2.69	12	12	6.63	28	18	20	7	8.13	15.81	9.13	30	17.25	1	1	-	-
2000A20	2000B20	2.69	12	12	6.63	12.63	18.50	20	8	9	6.25	9.50	27.25	16.75	1	0.75	44	2.50
2000A40	2000B40	2.69	12	12	6.63	12.63	18.50	20	8	9	6.25	9.50	27.25	16.75	1	0.75	44	2.50
	2000B60	2.69	12	12	6.63	28	18	20	7	8.13	15.81	9.13	30	17.25	1	1	-	-
	3000B40	2.69	12	14	8.63	15.50	20	21.50	9	9.50	9.50	12.50	33	20.25	1	0.75	51	4
	3500B80	4.69	12.75	18	8.63	32	20	22	10	8.19	30.81	13.50	34.50	20.25	1	1	-	-
4000A20	4000B20	2.69	12	14	8.63	15.50	20	21.50	9	9.50	9 1/2	12.50	33	23.81	1	0.75	51	4
	4500B50	2.69	12	14	8.63	15.50	20	21.50	9	9.50	14	12.50	33	21.38	1	0.75	51	4
	6000B20	3.63	16	18	10.75	18	25	27.25	11.50	12	8.50	13.50	38	25.50	1	1.13	58	6
	6000B40	3.63	16	18	10.75	18	25	27.25	11.50	12	11.63	13.50	38	22.75	1	1.13	58	6
	10000B20	3.63	16	20	12.75	22.50	28	31	12.63	13.19	8.88	14.75	47	28.25	1	1.50	58	6
	10000B40	3.63	16	20	12.75	22.50	28	31	12.63	13.19	11	14.75	47	26.25	1	1.50	58	6
	15000B20	6	24	30	18	3 at 18	34	37	19.88	15.06	7.25	20	60.75	39	1.88	1.50	58	6
	25000B25	8	24	40	24	4 at 17	37	40	22	15.50	15.75	26.25	72	48.25	2	1.50	58	6

		Dimensions in millimeters																
200A40	200B40	1118	203	203	114	457	343	394	152	146	191	191	508	346	635	635	-	-
250A20	250B20	1118	203	203	114	203	343	394	152	146	191	191	508	346	635	635	-	-
500A20	500B20	1118	203	203	114	457	343	394	152	146	237	191	508	371	635	635	-	-
500A40	500B40	1118	203	203	114	457	343	394	152	146	237	191	508	371	635	635	-	-
700A40	700B40	1118	203	203	114	457	343	394	152	146	237	191	508	371	635	635	-	-
800A20	800B20	1118	203	203	114	457	343	394	152	146	237	191	508	371	635	635	-	-
1300A20	1300B20	68	305	305	168	321	470	508	203	229	127	241	692	425	635	19	1118	64
1400A40	1400B40	68	305	305	168	321	470	508	203	229	203	241	692	425	635	19	1118	64
	1600B90	68	305	305	168	711	457	508	178	206	402	232	762	438	635	635	-	-
2000A20	2000B20	68	305	305	168	321	470	508	203	229	159	241	692	425	635	19	1118	64
2000A40	2000B40	68	305	305	168	321	470	508	203	229	159	241	692	425	635	19	1118	64
	2000B60	68	305	305	168	711	457	508	178	206	402	232	762	438	635	635	-	-
	3000B40	68	305	356	219	394	508	546	229	241	241	318	838	514	635	19	1295	102
	3500B80	119	324	457	219	813	508	559	254	208	783	343	876	514	635	635	-	-
4000A20	4000B20	68	305	356	219	394	508	546	229	241	241	318	838	605	635	19	1295	102
	4500B50	68	305	356	219	394	508	546	229	241	356	318	838	543	635	19	1295	102
	6000B20	92	406	457	273	457	635	692	292	305	216	343	965	648	635	29	1473	152
	6000B40	92	406	457	273	457	635	546	292	305	295	343	965	578	635	29	1473	152
	10000B20	92	406	508	324	572	711	787	321	335	225	375	1194	718	635	38	1473	152
	10000B40	92	406	508	324	572	711	787	321	335	279	375	1194	667	635	38	1473	152
	15000B20	152	610	762	457	3 at 457	864	940	505	383	184	508	1543	991	48	38	1473	152
	25000B25	203	610	1016	610	4 at 432	940	1016	559	394	400	667	1829	1226	1295	38	1473	152

Bolt sizes: 200A40 through 800B20: 1/2" (13 mm); 1300A20 through 4500B50: 5/8" (16 mm); 6000B20 through 25000B25: 3/4" (19 mm). Dimensions are subject to change. Contact factory for certified prints.

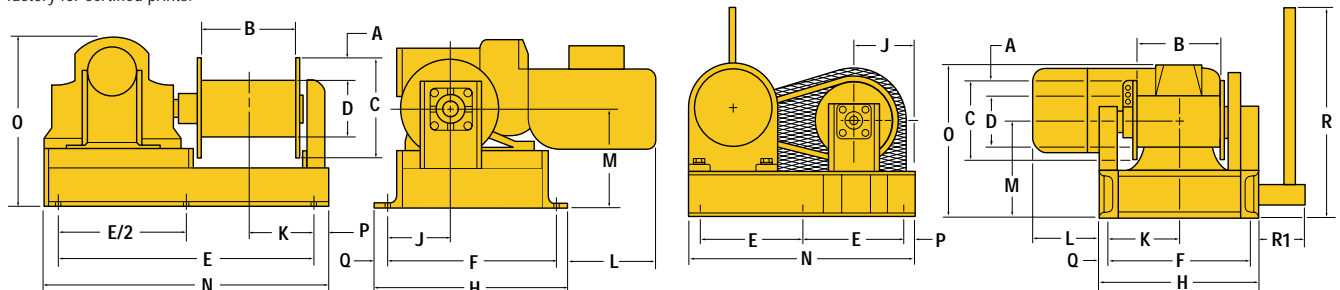

**Direct drive model** – for model numbers 200A40/B40, 250A40/B40, 500A20/B20, 500A40/B40, 700A40/B40, 800A40/B40, 1600B90, 2000B60, and 3500B80  
Dimensions are subject to change. Contact factory for certified prints

**Chain drive from motor drum; design factor 6:1 or more** – for model numbers 1300A20/B20, 1400A40/B40, 2000A20/B20, 2000A40/B40, 3000B40, 4000A20/B20, 4500B50, 6000B20, 6000B40, 10000B20, 10000B40, 15000B20, and 25000B25

**Electric Winches and Car Pullers**  
**200 to 25000 lb (91 to 11364 kg) capacity**



<b>Winch options</b>	<b>Code</b>	<b>Description</b>
<b>Drum divider</b>	<b>D</b>	One steel flange is welded to the center of the drum. Includes second cable anchor. Standard is based on right lay rope for overwound rotation.
<b>Grooved drum</b>	<b>G</b>	Standard drum lengths only. Grooving is left hand spiral for overwind rope take-off. Recommended rope is right lay. Engineering review is required for units specified with longer drums and/or divider flanges.
<b>Heater in motor</b>	<b>H</b>	Recommended for extreme high or low temperature conditions, to eliminate condensation in the motor enclosure.
<b>Marine duty</b>	<b>M</b>	<p>Marine duty motor and gearboxes. Marine duty 3 phase electric winches are designed to meet the Institute of Electrical and Electronic Engineers (IEEE) specification number 45 for shipboard severe duty and washdown environments.</p> <p>To meet the requirements of such harsh operating conditions, all marine duty motors are built with cast iron end shields and special stators constructed of "Silafront-13," an aluminum-silicon alloy resistant to corrosive elements. All motor windings are treated with "Polane," a unique polyurethane coating which prevents corrosion due to condensation. Marine duty winch motors also incorporate class "F" electrical insulation and have a 1.15 service factor capable of delivering, if needed, 115% of the motor's rated horsepower during the entire duty cycle of that motor.</p> <p>Should the user so desire, each marine duty winch motor can be furnished with a 1/8" NPT drain plug rather than the standard 1/8" drain hole to prevent water damage should the motor be submerged. <b><i>This special option must be requested at the time of order.</i></b></p> <p>All marine duty 3 phase winches are supplied with gearboxes that incorporate protected breathers to equalize gearbox pressure without the risk of exposure to corrosive elements.</p> <p><b><i>Marine grade motor features apply to 3 phase motors only. Single phase motor manufacturers' interpretation of marine grade requirements vary. Therefore, motor features may vary. Please advise single phase motor requirements before ordering.</i></b></p>
<b>Marine 812 finish</b>	<b>P</b>	An excellent corrosion, chemical, and abrasive resistant alkyd enamel finish over a rust inhibitive primer.
<b>Rotary limit switch</b>	<b>S</b>	Rotary switch counts drum revolutions. Different ratios are available depending on actual rope travel. Specify rope travel distance between upper and lower limits so we may select the proper ratio. Please understand that rope spooling and rope stretch must be taken into account and final adjustments will be necessary.
<b>Torque limiter</b>	<b>T</b>	Adjustable clutch acts to limit pull by slipping when load exceeds setting. Mounted on the outboard side of drum.
<b>Sandblast/carbozinc</b>	<b>Z</b>	The best corrosion resistant primer available. Sandblast to "white" metal followed by an inorganic zinc primer. Marine 812 finish <b>(P)</b> recommended. Note: motors are chemically cleaned, not sandblasted.

## How to Order Classic Electric Winches and Car Puller Models

Specify complete model code as shown below. Electric winches and car pullers exclude winch control and starter options.

**Control options:** A control package consists of magnetic reversing starter and controls. Starter and control options may be ordered in two ways:

1. When specified in the model code, starters and controls will be mounted on the winch and tested. Installation charge additional.
2. By specifying part numbers, controls may be ordered separately for customer installation by a qualified electrician. Starter and control option packages consist of the following items:
  - A. Magnetic reversing starter, sized according to winch hp and voltage. Magnetic reversing starters with internal 110 volt control transformer are now standard. These starters are available in single and three phase models and are intended for use with either two motion control stations or pendants used in remote control applications.
  - B. Remote pendant or wall mount pushbutton control (requires the use of a magnetic reversing starter)
  - C. Reversing drum switch to be used when winch power supply is:  
Single phase: 115 volt to 1.5 hp, 230 volt to 2 hp. Three phase: 230/460 volt to 2 hp.

To use a reversing drum switch, a magnetic reversing starter is not required. Drum switches should only be mounted directly to the winch itself. Drum switches when used in this manner have a control voltage equal to the operating voltage of the winch. Drum switches are intended for mounting on the unit itself and must have their enclosures grounded to the electrical system ground.

Example: CP2000B40M2-12-8G-M4P3-50

Series	Line pull <sup>(1)</sup> 2nd layer (lbs)	Phase <sup>(2)</sup>	Speed (fpm)	Motor type	Voltage	-	Drum length (in.)	-	Wire rope size	Winch options	-	Starter options	Control options
CP	2000	B	40	M	2	-	12	-	8	G	-	M4	P3-50
CP = Carpuller model prefix		A = Single phase B = Three phase		1 = 115-1-60 2 = 230-1-60 230-3-60 3 = 380-3-50 4 = 460-3-60 5 = 575-3-60 6 = 208-3-60 7 = 415-3-50		Wire rope in sixteenths (e.g. 8/16 = 1/2 inch)		D = Drum divider flange G = Grooved drum H = Heater in motor P = Marine 812 finish Q = Special paint; please specify R = Press roller S = Rotary limit switch T = Torque limiter clutch Y = Electronic overload* Z = Sandblast/carbozinc primer		M4 = Mag. rev. starter NEMA 4		D1 = Drum switch NEMA 1 D4 = Drum switch NEMA 4 P3-XX = Pushbutton pendant NEMA 3R P4-XX = Pushbutton pendant NEMA 4 W4 <sup>(3)</sup> = Wall mount pushbutton station NEMA 4 XX = Specify hand held pendent control cord (ft)	
(-) = Std. Totally Enclosed Fan Cooled		M = Marine (three phase only) grade motor and gearbox											
<b>Drum extensions (see dim. B on previous page) Drum width in. (mm)</b>													
Model		8 (203)	12 (305)	16 (406)	20 (508)	24 (610)	30 (762)	36 (915)	42 (1067)				
200	- 800	Standard	yes	yes	yes	no	no	no	no				
1300	- 4500	no	Standard	yes	yes	yes	no	no	no				
6000	- 10000	no	no	Standard	yes	yes	yes	no	no				
15000	- 25000	no	no	no	no	Standard	yes	yes	yes				

\* Requires the purchase of a magnetic reversing starter (see control options)

(1) Please refer to specification chart for line pull information.

(2) Please specify voltages when ordering "A" models 115/230-1-60; "B" models 230/460-3-60, and for 380-3-50, 415-3-50 and 575-3-60.

(3) Wall mount pushbutton controls will be shipped loose for customer installation. The National Electrical Code requires wall mount control stations to be installed with conduit enclosed wiring.



**NEW!**

## Fulcrum Winch Series

5300 to 45600 lb (2409 to 20727 kg) capacity



**The new Fulcrum “E” series electric winches are designed to meet or exceed North American ANSI / ASME B30.7 standards while providing optimum performance in a rugged, safe, and versatile package.**

IR has combined over 70 years of electric winch manufacturing experience with input from a diverse group of endusers, riggers, and regulatory officials, to determine the design criteria for the new Fulcrum series of winches. Based on industry requirements to maximize safety, versatility, and reliability the Fulcrum “E” series is available in two basic configurations: “EP” for pulling applications, and “EL” for lifting applications. An extensive array of options further enhances the Fulcrum’s flexibility while its 5:1 design factor and **two year warranty** is your assurance of safe, dependable operation for the most demanding applications worldwide.



EP45600 (20 ton Electric Fulcrum Winch)

### ■ Standard features

- Meets or exceeds ANSI / ASME B30.7
- Lifting models with 18:1 D/d ratio (per ANSI / ASME B30.7)
- Pulling models with 15:1 D/d ratio (per ANSI / ASME B30.7)
- 5:1 design factor
- Winch motors are high torque design, rated for continuous duty totally enclosed fan cooled (TEFC)
- All worldwide voltages
- Wide selection of standard gear ratios and line speeds
- Automatic motor disc brake
- Fully enclosed, 95% efficient, planetary gear boxes
- Underwound or overwound cable take-offs
- Variable mounting configurations (inverted, side, etc.)
- **Two year warranty**
- Hydraulic and Man Rider™ models available on request

### Specifications:

#### for pulling winches at 15:1 D/d ratio

Frame	Rope size		Winch 1st layer rated load		Drum diameter		Flange diameter		Std. drum length		No. of layers	Capacity std. drum		Standard min. drum length		Standard max. drum length <sup>1</sup>	
	in.	mm	lbs	kg	in.	mm	in.	mm	in.	mm		ft	m	in.	mm	in.	mm
3	1/2	13	5300	2409	8.625	219	17	432	18	457	7	768	234	18	457	42	1067 <sup>1</sup>
3	9/16	14	6700	3045	8.625	219	17	432	18	457	6	577	176	18	457	42	1067 <sup>1</sup>
4	5/8	16	8200	3727	10.750	273	22	559	24	610	8	1216	371	18	457	48	1219
4	3/4	19	11700	5318	10.750	273	22	559	24	610	7	896	273	18	457	48	1219
5	7/8	22	15900	7227	14.000	356	28	711	24	610	7	962	293	18	457	48	1219
5	1	25.4	20600	9364	14.000	356	28	711	24	610	6	713	217	18	457	48	1219
6	1 1/8	29	26000	11818	16.000	406	34	864	24	610	7	877	267	18	457	48	1219
7	1 1/4	32	31900	14500	20.000	508	38	965	24	610	7	946	288	18	457	48	1219
7	1 3/8	35	38400	17455	20.000	508	38	965	24	610	6	721	220	18	457	48	1219
8	1 1/2	38	45600	20727	24.000	610	45	1143	30	762	6	974	297	24	610	60	1524

#### for lifting winches at 18:1 D/d ratio

Frame	Rope size		Winch 1st layer rated load		Drum diameter		Flange diameter		Std. drum length		No. of layers	Capacity std. drum		Standard min. drum length		Standard max. drum length	
	in.	mm	lbs	kg	in.	mm	in.	mm	in.	mm		ft	m	in.	mm	in.	mm
3	1/2	13	5300	2409	8.625	219	17	432	18	457	7	768	234	18	457	42	1067 <sup>1</sup>
3	9/16	14	6000	2722	9.750	248	17	432	18	457	5	505	154	18	457	42	1067 <sup>1</sup>
4	5/8	16	8200	3727	10.750	273	22	559	24	610	8	1216	371	18	457	48	1219
4	3/4	19	9200	4181	14.000	356	22	559	24	610	4	548	167	18	457	48	1219
5	7/8	22	14100	6409	16.000	406	28	711	24	610	6	873	266	18	457	48	1219
5	1	25.4	16400	7455	18.000	457	28	711	24	610	4	526	160	18	457	48	1219
6	1 1/8	29	21300	9682	20.000	508	34	864	24	610	6	845	258	18	457	48	1219
7	1 1/4	32	27000	12273	24.000	610	38	965	24	610	5	715	218	18	457	48	1219
7	1 3/8	35	32600	14818	24.000	610	38	965	24	610	4	505	154	18	457	48	1219
8	1 1/2	38	42400	19273	26.000	660	45	1143	30	762	6	1033	315	24	610	60	1524

<sup>1</sup> For drum layers longer than standard contact Technical Sales

**NEW!****Fulcrum Winch****200 to 50000 lb (91 to 22680 kg) capacity****Specifications:**

Rope size in. mm	Pulling winches, 1st layer rated load line speed				Lifting winches, 1st layer rated load line speed				
	lbs	kg	fpm	m/min	lbs	kg	fpm	m/min	
<b>Frame 3</b>									
1/2	13	5300	2409	18	5.5	5300	2409	18	5.5
1/2	13	5300	2409	28	8.5	5300	2409	28	8.5
1/2	13	5300	2409	39	11.9	5300	2409	39	11.9
1/2	13	5300	2409	59	18.0	5300	2409	59	18.0
1/2	13	5300	2409	86	26.2	5300	2409	86	26.2
1/2	13	5300	2409	101	30.8	5300	2409	101	30.8
9/16	14	6700	3045	23	7.0	6000	2727	25	7.6
9/16	14	6700	3045	34	10.4	6000	2727	38	11.6
9/16	14	6700	3045	48	14.6	6000	2727	53	16.2
9/16	14	6700	3045	69	21.0	6000	2727	77	23.5
9/16	14	6700	3045	87	26.5	6000	2727	97	29.6
9/16	14	6700	3045	102	31.1	6000	2727	114	34.7
<b>Frame 4</b>									
5/8	16	8200	3727	11	3.4	8200	3727	11	3.4
5/8	16	8200	3727	19	5.8	8200	3727	19	5.8
5/8	16	8200	3727	24	7.3	8200	3727	24	7.3
5/8	16	8200	3727	38	11.6	8200	3727	38	11.6
5/8	16	8200	3727	54	16.5	8200	3727	54	16.5
5/8	16	8200	3727	79	24.1	8200	3727	79	24.1
5/8	16	8200	3727	99	30.2	8200	3727	99	30.2
5/8	16	8200	3727	117	35.7	8200	3727	117	35.7
3/4	19	11700	5318	14	4.3	9200	4181	18	5.5
3/4	19	11700	5318	20	6.1	9200	4181	25	7.6
3/4	19	11700	5318	25	7.6	9200	4181	31	9.5
3/4	19	11700	5318	46	14.0	9200	4181	58	17.7
3/4	19	11700	5318	55	16.8	9200	4181	70	21.3
3/4	19	11700	5318	64	19.5	9200	4181	81	24.7
3/4	19	11700	5318	81	24.7	9200	4181	103	31.4
3/4	19	11700	5318	101	30.8	9200	4181	128	39.0

**Specifications:**

Rope size in. mm	Pulling winches, 1st layer rated load line speed				Lifting winches, 1st layer rated load line speed				
	lbs	kg	fpm	m/min	lbs	kg	fpm	m/min	
<b>Frame 5</b>									
7/8	22	15900	7227	21	6.4	14100	6409	23	7.0
7/8	22	15900	7227	29	8.8	14100	6409	32	10.0
7/8	22	15900	7227	36	11.0	14100	6409	40	12.2
7/8	22	15900	7227	82	25.0	14100	6409	92	28.0
1	25.4	20600	9364	21	6.4	16400	7455	26	7.9
1	25.4	20600	9364	25	7.6	16400	7455	31	9.5
1	25.4	20600	9364	29	8.8	16400	7455	36	11.0
1	25.4	20600	9364	36	11.0	16400	7455	46	14.0
<b>Frame 6</b>									
1 1/8	29	26000	11818	18	5.5	21300	9682	22	6.7
1 1/8	29	26000	11818	26	7.9	21300	9682	32	10.0
1 1/8	29	26000	11818	38	11.6	21300	9682	47	14.3
1 1/8	29	26000	11818	75	22.9	21300	9682	91	27.7
1 1/8	29	26000	11818	90	27.4	21300	9682	110	33.5
<b>Frame 7</b>									
1 1/4	32	31900	14500	21	6.4	27000	12273	24	7.3
1 1/4	32	31900	14500	26	7.9	27000	12273	31	9.5
1 1/4	32	31900	14500	34	10.4	27000	12273	40	12.2
1 1/4	32	31900	14500	43	13.1	27000	12273	51	15.5
1 1/4	32	31900	14500	50	15.2	27000	12273	59	18.0
1 3/8	35	38400	17454	22	6.7	32600	14818	25	7.6
1 3/8	35	38400	17454	25	7.6	32600	14818	29	8.8
1 3/8	35	38400	17454	35	10.7	32600	14818	41	12.5
1 3/8	35	38400	17454	43	13.1	32600	14818	51	15.5
1 3/8	35	38400	17454	51	15.5	32600	14818	60	18.3
<b>Frame 8</b>									
1 1/2	38	45600	20727	21	6.4	42400	19273	23	7.0
1 1/2	38	45600	20727	31	9.5	42400	19273	33	10.1
1 1/2	38	45600	20727	37	11.3	42400	19273	39	11.9
1 1/2	38	45600	20727	47	14.3	42400	19273	50	15.2

**Drum Lengths**

Models	Standard Drum Length	Optional Drum length	
		in.	mm
<b>Frame 3</b>			
Pulling EL5300	18 457	30	762
Lifting EL6000	18 457	30	762
<b>Frame 4</b>			
Pulling EL8200	24 610	36	914
Lifting EL9200	24 610	36	914
<b>Frame 5</b>			
Pulling EL15900	24 610	36	914
Lifting EL16400	24 610	36	914
<b>Frame 6</b>			
Pulling EL21300	24 610	36	914
<b>Frame 7</b>			
Pulling EL31900	24 610	36	914
Lifting EL27000	24 610	36	914
Pulling EL38400	24 610	36	914
Lifting EL32600	24 610	36	914
<b>Frame 8</b>			
Pulling EL45600	30 762	42	1069
Lifting EL42400	30 762	42	1069

**NEW!**

# Fulcrum Winch

## 200 to 50000 lb (91 to 22680 kg) capacity



### Dimensions <sup>1</sup>

#### Pulling

Frame	Model	A		B		C		D		E		F		G		H		J	
		in.	mm	in.	mm	in.	mm	in.	mm	in.	mm	in.	mm	in.	mm	in.	mm	in.	mm
3	EP5300-18-18	18	457	8.63	219	4.19	106	17	432	23.5	597	29.54	737	0.5	13	23	584	15	381
3	EP6700-23-18	18	457	8.63	219	4.19	106	17	432	23.5	597	29.54	737	0.5	13	23	584	15	381
4	EP8200-19-24	24	610	10.75	273	5.63	143	22	559	28.5	711	40.54	1030	0.5	13	27.5	699	17.5	445
4	EP11700-14-24	24	610	10.75	273	5.63	143	22	559	28.5	711	40.54	1030	0.5	13	27.5	699	17.5	445
5	EP15900-21-24	24	610	14	357	7	178	28	711	33.5	851	42.5	1080	0.5	13	34.5	876	22.5	572
5	EP20600-21-24	24	610	14	357	7	178	28	711	33.5	851	42.5	1080	0.5	13	34.5	876	22.5	572
6	EP26000-18-24	24	610	16	406	9	229	34	864	42.5	1080	44.82	1138	0.5	13	38.5	978	25.5	648
7	EP31900-21-24	24	610	20	508	9	229	38	965	-	-	-	-	-	-	-	-	-	
7	EP38400-25-24	24	610	20	508	9	229	38	965	-	-	-	-	-	-	-	-	-	
8	EP45600-21-30	30	762	24	610	10.5	267	45	1143	-	-	-	-	-	-	-	-	-	

<sup>1</sup> Dimensions are subject to change. Contact technical sales for certified prints.  
 Dimensions are for standard base models only.

### Dimensions <sup>1</sup>

#### Lifting

Frame	Model	A		B1		C		D		E		F		G		H		J	
		in.	mm	in.	mm	in.	mm	in.	mm	in.	mm	in.	mm	in.	mm	in.	mm	in.	mm
3	EL5300-18-18	18	457	8.63	219	4.19	106	17	432	23.5	597	29.54	737	0.5	13	23	584	15	381
3	EL6700-25-18	18	457	9.75	248	3.63	92	17	432	23.5	597	29.54	737	0.5	13	23	584	15	381
4	EL8200-19-24	24	610	10.75	273	5.63	143	22	559	28.5	711	40.54	1030	0.5	13	27.5	699	17.5	445
4	EL9200-18-24	24	610	14	357	4	102	22	559	28.5	711	40.54	1030	0.5	13	27.5	699	17.5	445
5	EL14100-23-24	24	610	16	406	6	152	28	711	33.5	851	42.5	1080	0.5	13	34.5	876	22.5	572
5	EL16400-26-24	24	610	18	457	5	127	28	711	33.5	851	42.5	1080	0.5	13	34.5	876	22.5	572
6	EL21300-22-24	24	610	20	508	7	179	34	864	42.5	1080	44.82	1138	0.5	13	38.5	978	25.5	648
7	EL27000-24-24	24	610	24	610	7	179	38	965	-	-	-	-	-	-	-	-	-	
7	EL32600-29-24	24	610	24	610	7	179	38	965	-	-	-	-	-	-	-	-	-	
8	EL42400-23-30	30	762	26	660	9.5	241	45	1143	-	-	-	-	-	-	-	-	-	

<sup>1</sup> Dimensions are subject to change. Contact technical sales for certified prints.  
 Dimensions are for standard base models only.

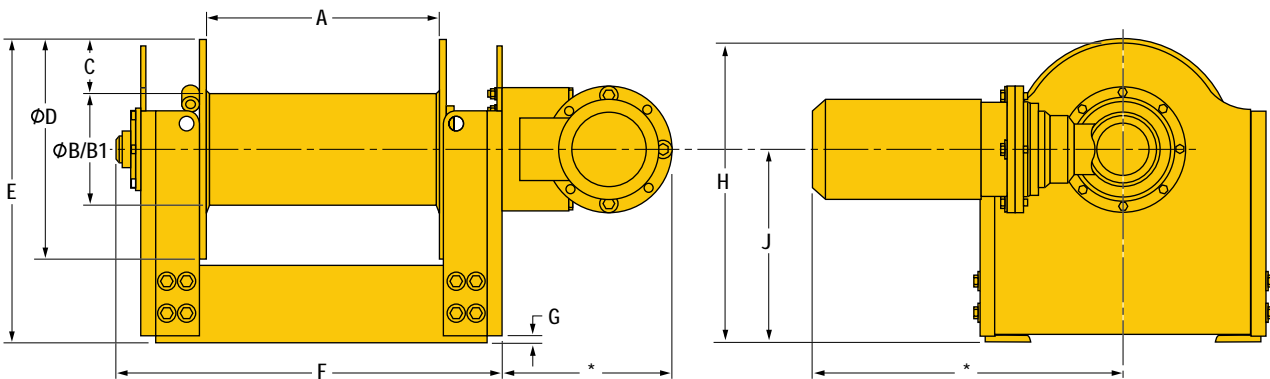

**NEW!**

# Fulcrum Winch

200 to 50000 lb (91 to 22680 kg) capacity



## How to Order:

Specify the complete model as shown. **Example: EL5300-28-18-8G-M4-P4-20** is an electric powered lifting winch with a 5300 lb capacity, a 28 fpm line speed, an 18 inch drum, 460-3-60 volt, with grooved drum, NEMA 4 starter and pushbutton, and 20 feet of control cord.

Series	Application	Capacity	Line speed	Drum length	Voltage	Winch options	Starter/drives	Control station	Cord length (ft)
<b>E</b>	<b>L</b>	<b>5300</b>	<b>28</b>	<b>18</b>	<b>8</b>	<b>G</b>	<b>M4</b>	<b>P4</b>	<b>20</b>
<b>E</b> = Electric <b>H</b> = Hydraulic <sup>3</sup>	<b>L</b> = Lifting <b>P</b> = Pulling <b>MR</b> = Electric Manrider <sup>3</sup>	(See table below)	(See table below)	(See std. drum width chart below)	<b>1</b> = 115-1-60 <b>2</b> = 230-1-60 <b>3</b> = 208-3-60 <b>4</b> = 230-3-60 <b>5</b> = 380-3-50 <b>6</b> = 400-3-50 <b>7</b> = 415-3-50 <b>8</b> = 460-3-60 <b>9</b> = 575-3-60 <b>0</b> = Used w/hydraulic and air units	<b>A</b> = Air operated drum brake <b>C</b> = Special motor per customer specs <b>D</b> = Drum divider flange; <b>X</b> = no. of dividers <b>F</b> = Free-spooling clutch <b>G</b> = Grooved drum <sup>(3)</sup> <b>H</b> = Horizontal load reversing drum <sup>(4)</sup> <b>J</b> = Space heater in motor <b>K</b> = Hand crank for emergency manual operation <b>L</b> = Drum locking pin <b>M</b> = Marine duty, IEEEE45 motor <b>N</b> = Mirror image unit <b>P</b> = Marine 812 finish <b>Q</b> = Special paint; please specify <b>R</b> = Press roller on drum <b>S</b> = NEMA 4 upper & lower, rotary limit switch <b>T</b> = Dual speed motor <b>U</b> = Manual level wind <b>W</b> = Slack rope detector <b>X</b> = Drum guard <b>Y</b> = Electronic overload limiter <b>Z</b> = Sandblast / carbozinc	<b>M4</b> = NEMA 4 starter <b>M4X</b> = NEMA 4X starter <b>V</b> = Variable frequency drive. Customer to specify control requirements. <b>X</b> = Explosion-proof starter. Customer to specify class, division and group.	<b>D1</b> = Drum switch NEMA 1 <b>D4</b> = Drum switch NEMA 4 <b>E</b> = Explosion-proof controller. Customer to specify class, division and group. <b>P4</b> = Pushbutton NEMA 4 <b>P4X</b> = Pushbutton NEMA 4X <b>W1</b> = Wall mount pushbutton station, NEMA 1 <b>W4</b> = Wall mount pushbutton station, NEMA 4	

### First layer capacities

Frame	Pulling capacities	Line speeds / fpm <sup>(1)</sup>	Lifting capacities	Line speeds / fpm <sup>(1)</sup>	Std. drum width <sup>(2)</sup>
<b>3</b>	<b>EP</b> 5300 lbs / 2409 kg	18, 28, 39, 59, 86, 101	<b>EL</b> 5300 lbs / 2409 kg	18, 28, 39, 59, 86, 101	18 in. / 457 mm
<b>3</b>	<b>EP</b> 6700 lbs / 3045 kg	23, 34, 48, 69, 87, 102	<b>EL</b> 6000 lbs / 2727 kg	25, 38, 53, 77, 97, 114	18 in. / 457 mm
<b>4</b>	<b>EP</b> 8200 lbs / 3727 kg	11, 19, 24, 38, 54, 79, 99, 117	<b>EL</b> 8200 lbs / 3727 kg	11, 19, 24, 38, 54, 79, 99, 117	24 in. / 610 mm
<b>4</b>	<b>EP</b> 11700 lbs / 5318 kg	14, 20, 25, 46, 55, 64, 81, 101	<b>EL</b> 9200 lbs / 4181 kg	18, 25, 31, 58, 70, 81, 103, 128	24 in. / 610 mm
<b>5</b>	<b>EP</b> 15900 lbs / 7227 kg	21, 29, 36, 82	<b>EL</b> 14100 lbs / 6409 kg	23, 32, 40, 92	24 in. / 610 mm
<b>5</b>	<b>EP</b> 20600 lbs / 9364 kg	21, 25, 29, 36	<b>EL</b> 16400 lbs / 7455 kg	26, 31, 36, 46	24 in. / 610 mm
<b>6</b>	<b>EP</b> 26000 lbs / 11818 kg	18, 26, 38, 75, 90	<b>EL</b> 21300 lbs / 9682 kg	22, 32, 47, 91, 110	24 in. / 610 mm
<b>7</b>	<b>EP</b> 31900 lbs / 14500 kg	21, 26, 34, 43, 50	<b>EL</b> 27000 lbs / 12273 kg	24, 31, 40, 51, 59	24 in. / 610 mm
<b>7</b>	<b>EP</b> 38400 lbs / 17455 kg	22, 25, 35, 43, 51	<b>EL</b> 32600 lbs / 14818 kg	25, 29, 41, 51, 60	24 in. / 610 mm
<b>8</b>	<b>EP</b> 45600 lbs / 20727 kg	21, 31, 37, 47	<b>EL</b> 42400 lbs / 19273 kg	23, 33, 39, 50	30 in. / 762 mm

(1) First layer line speed

(2) Other drum lengths available

(3) Grooving is based on left hand spiral for overwind take-off. The size of the grooving is based on the recommended wire rope size specified for each frame and is selected to meet ANSI / ASME B30.7 recommendations. If different size grooving is required it must be specified by enduser at time of order.

(4) Wire rope size and cable take-offs must be specified at time of an order.

## Air Winches

*The IR line of air winches incorporates the best ideas and innovations of Beebe International, Samia of France and the original IR line of products. The combined experience of these companies adds up to over 200 years of solving the most challenging lifting, pulling and positioning applications in the world's toughest industries.*

### Why choose an air winch?

- Air winches are simple, rugged, reliable sources of enormous lifting and pulling power for their weight.
- Air motors cannot burn out; they can be stalled all day without damage, making air winches ideal for tensioning applications, such as holding a barge in place. And when air motors are stalled, they use no air!
- Air winches have exceptional load "spotting" ability.
- Speed control is variable from a slow creep to full speed.
- Air winches are well-suited for applications in hot, cold, dusty, dirty, explosive and wet conditions. They pose no electric shock hazard, require no special enclosures, and there are no high-pressure hydraulic lines to leak.
- Air winches have an unlimited duty cycle.
- Air winches can be easily reeved for increased capacity.
- Air winches are easy to service, maintain, and repair.



**IR offers the broadest selection of air winches in the world, including utility and personnel lifting winches. Here's how IR air winches are rated:**

■ **Utility rated air winches**

- Used for lifting, pulling or tensioning of materials, up to the rated capacity of the winch.
- Meet ANSI / ASME B30.7
- Rated with a 5:1 design factor for lifting and lowering loads and a 3.5:1 design factor for pulling loads
- Versions available to meet the European Machinery Directives
- Clutches for free spooling wire rope are allowed in the U.S.A. for both lifting and pulling; in Europe, they are allowed for pulling applications only .
- Applications include construction, mining, offshore oil, heavy industrial, refineries, utilities, shipbuilding, petrochemical
- Not to be used for lifting people

■ **Offshore Man Rider™**

- Offshore Man Riders have Type Approval and can be certified by one or more of the following independent third party organizations for the offshore oil and drilling industry:
  - Det Norske Veritas (DNV)
  - American Bureau of Shipping (ABS)
  - Lloyd’s Register of Shipping (LRS)
- Offshore Man Riders have been designed according to the regulations of one or more of the following regulatory bodies:
  - Norwegian Petroleum Directorate (NPD)
  - Norwegian Maritime Directorate (NMD)
  - UK HSE
- Type Approved for lifting and lowering of people with 8:1 design factor
- Force 5 models are dual rated for utility lifting at 5:1 design factor
- Dual brakes: one automatic and one manual or dual automatic

 **-E = Compliance with the European Machinery Directive. Includes as standard on utility rated winches:**

- 1 Main air supply shutoff located at the winch for throttle control models and on the pendant for remote control models.
- 2 Overload device for lift rated winches
- 3 Drum guard
- 4 Muffler
- 5 CE documentation

■ **“Gulf” Man Rider™**

The Gulf Man Rider was specifically designed to meet the requirements for a personnel lifting winch for use on offshore rigs in the Gulf of Mexico. Additionally, the design has been type approved by DNV. The Gulf Man Rider is backed by IR’s experience and comes with a Det Norske Veritas (DNV) witness to our load test.

■ **Onshore Man Rider™**

- Onshore Man Riders have been designed to meet the requirements of ANSI / ASME A10.22-1990 for “Rope Guided and Nonguided Worker’s Hoists - Safety Requirements”.
  - Addresses OSHA requirements where applicable
  - Typical applications include tower and chimney construction and maintenance, dams, mines, building construction

- Upper/lower limit switches, speed indicator, battery pack and dual brakes—one automatic and one manual—are standard
- Dual rated for personnel and material lifting—8:1 design factor for personnel; 5:1 design factor for materials
  - Line pulls are rated at top layer and line speeds at mid layer.
  - Third party Type Approved by ABS

**Man Rider air winch series quick selection guide**

Man Rider series	Rated line capacity/ lifting at top layer				Rated line speed/ lifting at top layer			
	personnel 8:1 DF		utility 5:1 DF		personnel 8:1 DF		utility 5:1 DF	
	lbs	kg	lbs	kg	fpm	m/min	fpm	m/min

*Meets Offshore requirements for one or more of the following: ABS, DNV, LRS, NMD, NPD and UK HSE*

FA150KGMR (-E)	330	150	n/a	n/a	95	29	n/a	n/a
LS150RLP (-E)	330	150	–	–	98	30	–	–
LS500RLP (-E)	1100	500	–	–	85	26	–	–
LS1000RLP (-E)	2200	1000	–	–	85	26	–	–
FA2BMR <sup>(1)</sup>	2500	1136	4000	1818	168	51	118	36
FA2MR (-E)	3180	1445	4400	2000	64	20	55	17
FA2.5AMR (-E) <sup>(1)</sup>	3125	1420	5000	2273	173	53	135	41
FA2.5MR (-E)	3180	1445	5000	2273	118	36	140	43
FA5AMR (-E) <sup>(1)</sup>	6250	2841	10000	4545	102	31	62	19
FA5MR (-E)	6875	3125	11000	5000	77	23	65	20

*Meets onshore requirements of ANSI / ASME A10.22-1990*

FA2MRA	2200	1000	3520	1600	91	28	66	20
FA2.5MRA	2200	1000	3520	1600	195	59	157	48
FA5MRA	4400	2000	7040	3200	87	26	74	22

(1) Rated at mid layer

■ **Piston motor or gear motor?**

IR air winches have a worldwide reputation for being rugged, durable and dependable in a vast array of applications. To meet the various needs of our customers, we offer two powerful yet different motors to power the winch.

- **Piston motors**—used in the Third Generation Force 5 Series, original Force 5 Series and IR Classics. Piston motors have great lugging characteristics—that is, they allow an operator to slowly move a load at an inching crawl for excellent spotting. Relatively high speeds are attained for moving loads long distances. Piston motors have internal “splash” lubrication and are fairly tolerant of “dirty” air. The new MP150 used on the FA2B air winch is lube-free!
- **Gear motors**—used exclusively in the Pullstar™ (PS) and Liftstar™ (LS) Series. Gear motors have only two moving parts, which reduces the complexity of motor maintenance, and are “lube-free”. The high torque feature provides outstanding steady slow speed characteristics. High speeds are not obtained with this type of motor. Gear motors will tolerate the wet and dirty air supply typically found in mines, foundries, steel mills, etc.

# Air Winch Selection Guide

## 330 to 22000 lb (150 to 10000 kg) capacity



### Utility air winch quick selection guide

(See specific series for complete technical information)

#### LIFTING: ANSI/ASME B30.16 allowable rated line pulls (5:1 design factor)

Utility models	First layer				Mid Layer				Top Layer				Average flow required	
	Capacity		Speed		Capacity		Speed		Capacity		Speed		cfm	m <sup>3</sup> /min.
	lbs	kg	fpm	m/min	lbs	kg	fpm	m/min	lbs	kg	fpm	m/min		
LS150R	455	207	103	31	380	173	115	35	330	150	138	42	78	2.2
LS300R	840	382	56	17	740	336	63	19	660	300	69	21	78	2.2
BU7A	1200	545	36	11	1000	454	43	13	1000	454	39	12	50	1.4
LS600R	1680	764	26	8	1480	673	30	9	1325	600	34	10	78	2.2
EU, EUL	2100	955	62	19	2000	909	68	21	2000	909	64	20	100	2.8
LS1500R <sup>(1)</sup>	4000	1818	19	6	3600	1636	21	6	3300	1500	23	7	125	3.5
FA2B	5000	2273	79	24	4000	1818	96	29	3200	1455	122	37	350	9.9
FA2.5A	5000	2273	119	36	5000	2273	114	35	4100	1864	141	43	700	19.8
HU40A	5000	2273	44	14	4000	1818	57	18	3200	1455	70	22	291	8.2
LS2000R	6200	2818	47	14	5150	2341	56	17	4400	2000	66	20	354	10.0
FA2	6600	3000	31	9	5200	2364	40	12	4400	2000	47	14	280	7.9
FA2.5	7000	3182	97	30	5800	2636	117	36	5000	2273	132	40	700	19.8
FA5A	11400	5182	40	12	10000	4545	50	15	8000	3636	62	19	700	19.8
FA5T	12500	5682	47	14	11300	5136	52	16	8400	3818	70	21	700	19.8
FA5	12500	5682	47	14	12500	5682	48	15	11000	5000	54	16	700	19.8
LS5000R	15600	7091	23	7	12900	5864	28	9	11000	5000	33	10	354	10.0
FA7T	18800	8545	32	10	16700	7591	37	11	12600	5727	48	15	750	21.2
FA7	18800	8545	32	10	18800	8545	33	10	15400	7000	40	12	750	21.2
FA10	27200	12364	28	9	27100	12319	19	6	22000	10000	23	7	800	22.7

#### PULLING: ANSI/ASME B30.7 allowable rated line pulls (3.5:1 design factor)

Utility models	First layer				Mid Layer				Top Layer				Average flow required	
	Capacity		Speed		Capacity		Speed		Capacity		Speed		cfm	m <sup>3</sup> /min.
	lbs	kg	fpm	m/min	lbs	kg	fpm	m/min	lbs	kg	fpm	m/min		
BU7A	1500	682	26	8	1200	545	34	10	1000	454	39	12	50	1.4
PS1000R	2200	1000	15	5	1950	886	17	5	1740	791	19	6	78	2.2
EU, EUL	3000	1364	45	14	2600	1182	49	15	2000	909	64	20	100	2.8
FA2B	5100	2318	76	23	4000	1818	96	29	3200	1455	122	37	350	9.9
PS2400R <sup>(1)</sup>	5280	2400	12	4	4800	2182	13	4	4370	1986	14	4	125	3.5
FA2	6800	3091	29	9	5400	2455	37	11	4500	2045	44	13	280	7.9
FA2.5A	7100	3227	67	20	6400	2909	42	13	5400	2455	45	14	700	19.8
FA2.5	8000	3636	79	24	6600	3000	42	13	5300	2409	119	36	700	19.8
HU40A	5100	2318	42	13	4000	1818	54	17	3200	1455	68	21	291	8.2
PS4000R	8800	4000	13	4	7300	3318	16	5	6200	2818	18	5	354	10.0
FA5A	13100	5955	26/8	8	10000	4545	50	15	8000	3636	62	19	700	19.8
FA5T	18000	8182	32	10	11600	5273	50	15	8600	3909	67	20	700	19.8
FA5	18000	8182	32	10	14100	6409	41	12	11600	5273	50	15	700	19.8
PS10000R	22000	10000	8	2	18300	8318	10	3	15600	7091	11	3	354	10.0
FA7T	27000	12273	23	7	18100	8227	32	10	13600	6182	46	14	750	21.2
FA7	27000	12273	23	7	18100	8227	32	10	13600	6182	46	14	750	21.2
FA10	34000	15455	17	5	27100	12319	19	6	22000	10000	23	7	800	22.7

(1) Standard cable is overwound; LS1500R and PS2400R are underwound.

Note: Adding "-E" to model states compliance with European Machinery Directive. See previous page for explanation of compliance.

 **It is the user's responsibility to determine the suitability of these winches for any particular use and to check for compliance with applicable regulations.**

**How IR air winches are rated.**

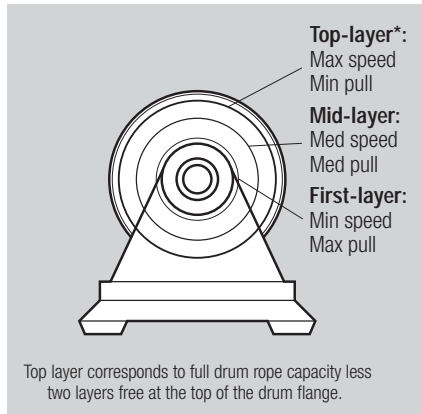

■ **Winch capacity:**

Winches can lift or pull the highest loads at the first layer, and can lift/pull the least at the top layer. This is due to the “torque arm” effect of the rope spooling on the winch drum. The closer the load is to the drum, the easier it is for the winch to turn and move the load. The further away the load is from the drum, the harder it is for the winch to turn.

■ **Winch speed:**

Winches generally move the load fastest at the top layer and slowest at the first layer. Think of your old record player. If you put a penny near the center of the record, it would simply spin at the same rate as the record. But if you put it near the outside edge, it would fly off. This is because the outer diameter of the record is travelling faster than the inner diameter. The same is true for a winch drum, and consequently the wire rope.

■ **Follow these guidelines to choose the correct utility winch for your application:**

First, consider these three fundamental questions:

1. How much is to be lifted, pulled, or tensioned?
2. How fast is the load to be moved (if at all)?
3. How much wire rope is needed?

There is a handy checklist at the back of the catalog designed to help you answer these questions and guide you through the selection process. Your IR sales representative, authorized distributor, and factory FAST team are also ready to assist you in finding solutions for all your winch related applications.

**Lifting applications** are generally defined as those that require the brake to be engaged to prevent the load from falling. Refer to the quick selection guide earlier in this section.

a. **Choose a winch with a lifting capacity equal to or greater than your application load.**

➤ **Tip: Consider using a pulley to increase capacity, reduce speed, and for better load control.**

b. **Make sure the average speed meets your criteria for cycle time.**

c. **Wire rope selection is based on a 5:1 design factor and an 18:1 D/d ratio.** The 18:1 D/d ratio is an ANSI / ASME B30-7 recommendation and is calculated as  $D + d / d$  where D = winch barrel diameter and d = wire rope size. The higher the ratio, the longer the wire rope life. As a guideline, this ratio should never go below 15:1. The use of 6 x 37 rope will increase flexibility.

➤ **Tip: Winches with lower gear ratios overhaul better; that is, the load will run them backwards in a controlled descent with the throttle off. By applying the manual band brake, exceptional spotting can be achieved.**

**Auto brakes are always recommended with remote control operation.**

d. **Either manual or automatic brakes are suitable, although automatic brakes are recommended for lifting applications.**

e. **Clutches:** In the U.S.A., clutches are permitted on lifting winches. Although we don't usually recommend them, for certain lifting applications they make sense. In Europe, clutches are not allowed on lifting winches. The Liftstar series is for lifting and the Pullstar for pulling. They are the same winches, but with different ratings — and the Pullstar winches have clutches.

**Pulling applications:** Because of the 3.5:1 design criteria and the first layer rating, the ratings for pulling applications are higher for the same winch. Choose a winch based on capacity, speed and distance to be pulled. Manual band brakes and clutches are popular configurations, but each application has its own specific requirements. Again, consider pulleys to increase pulling capacity.

**Air supply and consumption:** All IR winches are rated at 90 psig (6.3 kg/m<sup>2</sup>) inlet pressure when the winch is running. The volume of air required is expressed in cubic feet per minute (cfm) or cubic meters per minute (m<sup>3</sup>/min). Refer to the charts or power curves for air consumption data for specific models. Compressor output must equal air consumption for continuous operation. Intermittent operation and/or air storage facilities will allow the use of smaller compressors. Hoses and fittings should be sized equal to or preferably one size larger than the winch inlet. Strainers, lubricators, filters and regulators are recommended based on air quality and the application. Mufflers and kits for piping away the exhaust are always suggested for operator safety and comfort.



**Classic Air Winch Series**  
 1000 and 2000 lb (454 and 909 kg) capacity



*Serving the construction and maintenance industries for more than fifty years, these time-tested IR air winches have become the industry standard. Economically priced, these proven performers offer exceptional quality and value. All IR Classic air winches meet ANSI / ASME B30.7*

■ **Standard features:**

1. Enclosed construction keeps out dirt and dust and seals in oil and grease for complete lubrication of all moving parts
2. Ball and roller bearings = reduced friction
3. Reliable band type brake securely holds rated load
4. Disengaging clutch allows free wheeling of rope drum for hand unwinding; standard on most models
5. Powerful radial piston air motor for positive starting with precise control
6. Self-closing throttle shuts off automatically when released, providing well-graduated control for spotting loads
7. Reversible motor allows full control of load by throttle when lifting, lowering and pulling
8. Throttle valve is designed to eliminate air leakage when the winch is idle

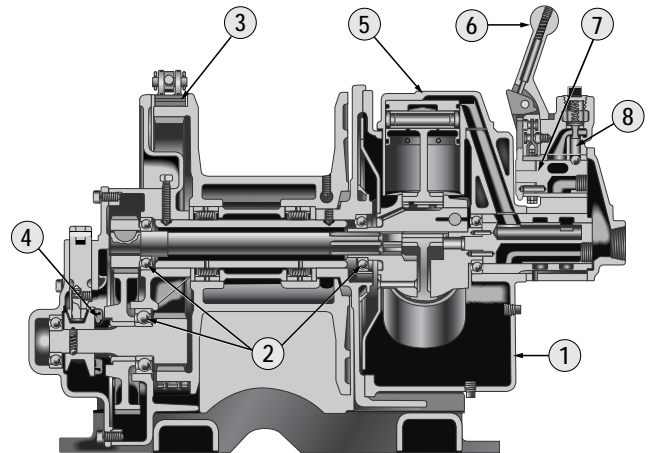

■ **Options:**

- Automatic band brake
- Remote control
- Tensioning manifold
- Sandblast and carbozinc primer
- Construction cages
- Remote pendent control
- Marine 812 finish

**Specifications: performance is based on 90 psi (6.3 bar) air inlet pressure with motor running**

Model	Line pull/half drum lbs	kg	Line spd/half drum fpm	m/min	Drum length in.	hp	Avg. air consump. scfm	Max. stall m <sup>3</sup> /min	1st layer lbs	kg	Pipe inlet in. (mm)	Hose size in. (mm)	Shipping wt lbs	kg
BU7A (-E)	1000	454	43	13	4.5	1.6	50	1.4	1950	886	1/2" (13 mm)	3/4" (19 mm)	90	41
BU7APTAB (-E)	1000	454	37	11	4.5	1.6	50	1.4	1950	886	1/2" (13 mm)	3/4" (19 mm)	118	54
EU	2000	909	68	21	4.81	4.4	100	2.8	4500	2045	3/4" (19 mm)	1" (25 mm)	360	164
EUABPT	2000	909	78	24	4.81	4.4	100	2.8	4500	2045	3/4" (19 mm)	1" (25 mm)	375	170
EUL	2000	909	68	21	12.88	4.4	100	2.8	4500	2045	3/4" (19 mm)	1" (25 mm)	490	222

Adding "-E" to model states compliance with European Machinery Directive. See Air Winch Selection Guide for explanation of compliance.



**BU7A 1000 lb**  
 (454 kg) capacity



**EU 2000 lb**  
 (909 kg) capacity

**Dimensions: BU7A and BU7APTAB**

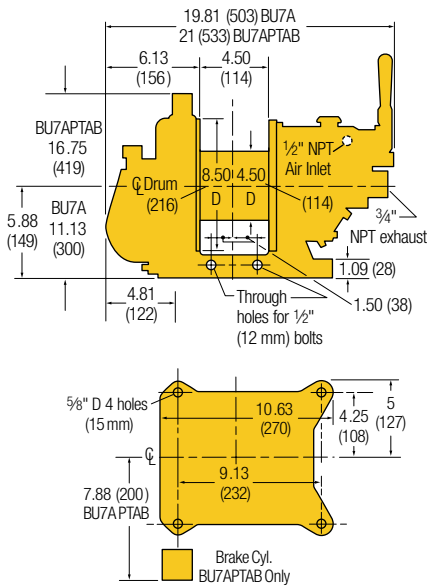

**Dimensions: EU**

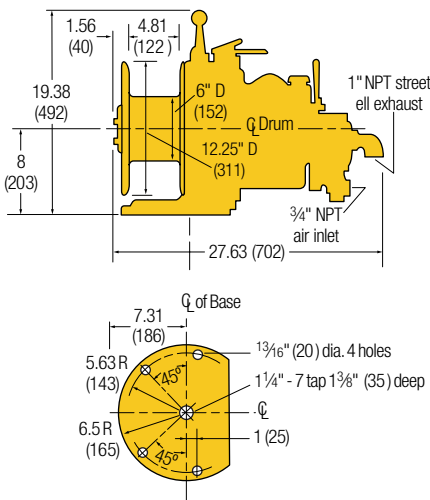

**Dimensions: EUL**

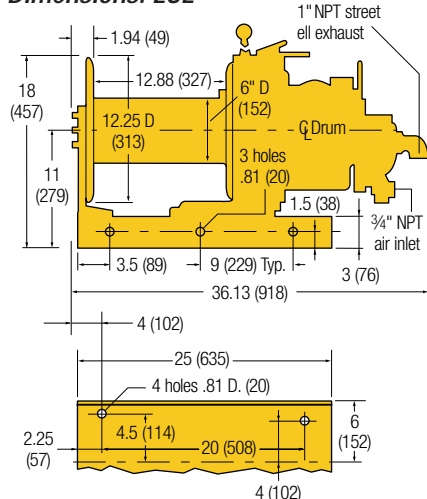

**Drum wire rope storage capacities**

Model	Capacity (mid layer)		Max length on winch (tightly wound)								Rope anchor hole	
	lbs	kg	1/4" (6 mm)	5/16" (8 mm)	3/8" (10 mm)	7/16" (11 mm)					in.	mm
BU7A (-E)	1000	455	228	70	132	40	-	-	-	-	11/32	9 mm
EU	2000	909	-	-	339	103	220	67	164	50	9/16	14 mm
EUL	2000	909	-	-	946	288	619	189	465	142	9/16	14 mm

**Kits and Accessories**

For series	Drum guard	Auto brake kit	Full flow remote control kit		Pilot air remote control kit	
			Std or auto brake	w/control block (1)	Std or auto brake	w/control block (2)
BU7APTAB	BU7A-K298A	Standard	Standard	pendent	-	-
BU7A (-E)	BU7A-K298A	-	-	-	-	-
EU	EU-K298A	EU-C709	EU-RC685AB	-	EU-PAK269AB	HU-PAK686AB
EUL	EUL-K298A	EU-C709	EU-RC685AB	-	EU-PAK269AB	HU-PAK686AB

- (1) Control should be within 30 ft (9.1 m) of winch for std brake and within 20 ft (6.1 m) for use with auto brake.
- (2) Control should be within 50 ft (15.2 m) of winch. Pilot remote control kits do not contain remote control valve chest.

**Other options**

Description	BU7A (-E)	Part number EUAB/PT	EU/EUL
Air strainer	EU-A267 (3/4 in. FNPT)	EU-A267 (3/4 in. FNPT)	EU-A267 (3/4 in. FNPT)
Lubricator	L30-06-000 (3/4 in. FNPT)	L30-06-000 (3/4 in. FNPT)	L30-06-000 (3/4 in. FNPT)
Exhaust muffler	50592 (1 in. NPT)	50592 (1 in. NPT)	50592 (1 in. NPT)
Valve Chest Assembly (1)	-	-	D10-A686

(1) Included with full flow remote control kits; required for pilot air remote control kits.

**How to Order:**

Specify the air winch series desired from the charts in the Air Winch Selection Guide. Remote control and/or auto brake options are available for most air winches. Add correct suffix to winch series if either or both are desired. Specify control hose length "XX" in feet. e.g. BU7APTAB15 is a BU7APTAB with 15 feet (4.6 m) of control hose.

Model	Remote control	Automatic Brake	-	Options	CE package
EU	PT = Pendent throttle	AB = Automatic brake	-	PZ	-E = Compliance with the European Machinery Directive (see Air Winch Selection Guide for description - BU7A only).
EU	RC = Remote control (full flow)			E = Construction cage	
EUL	XX = Specify control hose length in feet			P = Marine 812 finish	
				Q = Special paint; please specify	
				R = Natural gas operation	
				Z = Sandblast and carbozinc primer	

Notes:  
 Rope drum disengaging clutch is standard equipment on these winches.  
 Automatic brake is standard equipment on BU7APTAB and EUAB/PT.  
 Automatic brake and disengaging clutch may not be used together.

**Caution:** These winches are not to be used for lifting or lowering people.

Dimensions are in inches (mm)  
 Dimensions are subject to change. Contact factory for certified prints

# Liftstar™/Pullstar™ Gear Motor Air Winch Series

330 to 22000 lb (150 to 10000 kg) capacity



Designed for the demanding conditions found in tough environments with dirty air, these winches feature a low maintenance, highly reliable gear motor with high torque output that translates into smooth starts and stops. Light weight and compact for portability, yet the rugged all ductile iron construction makes it ready to take on your most challenging applications.

### Standard features:

LS150R, LS300R, LS600R, LS1500R, PS1000R, PS2400R

- Rugged gear motor tolerates dirty, wet supply air, and is suitable for use in tough environments such as steel mills, mining operations,

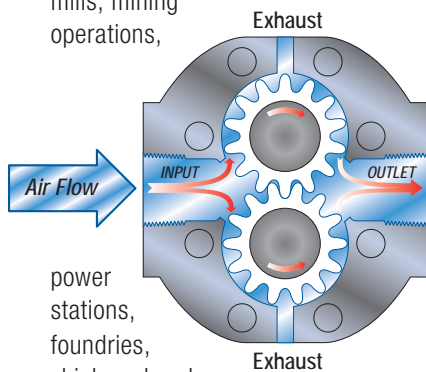

- power stations, foundries, shipboard and marine applications, chemical and petroleum industries.
- With only two moving parts, maintenance is low and motor life is long.
- High torque gear motor provides excellent spotting characteristics.
- Variable speed control provided by either the self-returning throttle lever or remote pendent handle.
- **Pullstar** has disengaging clutch for free-spooling unloaded wire rope.
- All ductile iron construction
- Automatic self-adjusting disc brake
- Continuous duty cycle
- Lightweight design for portability.
- Meets ASME B30.7 standards
- Exhaust air routed internally through drum barrel for reduced noise level.
- Operable at 70–100 psi (4.9–7 bar)
- Low air consumption
- Internal gear box in a compact space saving design

### Options and accessories:

- Drum guard
- Additional hose lengths for remote pendent up to 66 feet (20 m)
- Lubricator, filter and regulator
- Liquidator
- Pipeline strainer

### Standard features – heavy series:

LS2000R, LS5000R, PS4000R, PS10000R

The **Liftstar R** and **Pullstar R** air winches meet the requirements set by the FEM 9.511 standard which covers rating and classification; the Liftstars also meet the FEM 1001 standard for lifting equipment.

**Liftstar** winches have a 5:1 design factor for lifting at rated load. Lifting capacity is calculated at full drum minus two layers of wire rope. **Pullstar** winches are directly derived from the Liftstar series, but with a 3:1 line pull design factor. Pulling capacity is calculated at first layer of wire rope.

- Lube-free operation
- All ductile iron construction
- Designed in conformity with the latest European standards – FEM classification 1 Bm
- Automatic disc brake
- Reliable gear type air motor in composite material
- High efficiency planetary gear box
- Low noise level; quiet operation
- Disengaging clutch standard on **Pullstar** (pulling) series
- All units delivered with manufacturer's test certificate covering factory construction and performance
- CE package for European models includes as standard:
  - Drum guard
  - Main air shut-off emergency stop
  - Torque limiter (**Liftstar** lifting series only)
  - Instruction and safety manual
  - Declaration of conformity



PS1000R-L



PS2400RGC-L

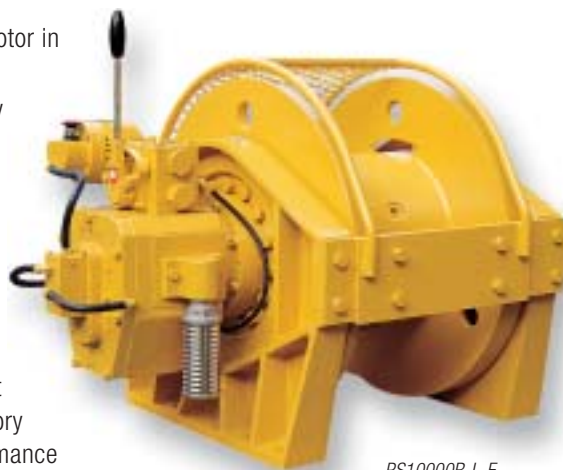

PS10000R-L-E

### Options and accessories:

- Drum guard
- Emergency stop
- Torque limiter (overload protection)
- Marine paint
- Offshore paint
- Skid frame
- Drum brake
- Press roller

# Liftstar™/Pullstar™ Gear Motor Air Winch Series

## 330 to 22000 lb (150 to 10000 kg) capacity



### Liftstar specifications: max. lifting values at 90 psi (6.3 bar) air inlet pressure with motor running

Series no.	Rated lifting at top layer				Average air consumption		Inlet size in.	Min hose in.	Net weight	
	lbs	kg	fpm	m/min	scfm	m <sup>3</sup> /min			lbs	kg
LS150R-L	330	150	138	42	78	2.2	1/2	1/2	60	27
LS300R-L	660	300	69	21	78	2.2	1/2	1/2	60	27
LS600R-L	1325	600	34	10.5	78	2.2	1/2	1/2	60	27
LS600RGC-L	1325	600	34	10.5	78	2.2	1/2	1/2	62	28
LS600R-PHM2	1325	600	34	10.5	78	2.2	1/2	1/2	81	37
LS600RGC-PHM2	1325	600	34	10.5	78	2.2	1/2	1/2	83	38
LS1500R-L	3300	1500	23	7	125	3.6	3/4	3/4	143	65
LS1500RGC-L	3300	1500	23	7	125	3.6	3/4	3/4	146	66
LS1500R-PH2M	3300	1500	23	7	125	3.6	3/4	3/4	166	75
LS1500RGC-PH2M	3300	1500	23	7	125	3.6	3/4	3/4	169	77
LS2000R	4400	2000	66	20	354	10	1 1/4	1 1/4	506	230
LS2000RGC	4400	2000	66	20	354	10	1 1/4	1 1/4	594	270
LS5000R	11000	5000	33	10	354	10	1 1/4	1 1/4	1408	640
LS5000RGC	11000	5000	33	10	354	10	1 1/4	1 1/4	1650	750

### Pullstar specifications: max. lifting and pulling are at 90 psi (6.3 bar) air inlet pressure with motor running

The PS1000R and PS2400R are fitted as standard with a free spool clutch. These winches can be used for lifting at reduced capacity to maintain 5:1 Design Factor only in countries that allow it, eg. USA. See information below for lifting capacities and line speeds for these countries.

Series no.	Rated pulling at first layer				Average air consumption		Inlet size in.	Min hose in.	Net weight	
	lbs	kg	fpm	m/min	scfm	m <sup>3</sup> /min			lbs	kg
PS1000R-L	2200	1000	15	5	78	2.2	1/2	1/2	62	28
PS1000RGC-L	2200	1000	15	5	78	2.2	1/2	1/2	83	38
PS1000R-PH2M	2200	1000	15	5	78	2.2	1/2	1/2	64	29
PS1000RGC-PH2M	2200	1000	15	5	78	2.2	1/2	1/2	85	39
PS2400R-L	5280	2400	12	4	125	3.6	3/4	3/4	146	66
PS2400RGC-L	5280	2400	12	4	125	3.6	3/4	3/4	169	77
PS2400R-PH2M	5280	2400	12	4	125	3.6	3/4	3/4	149	68
PS2400RGC-PH2M	5280	2400	12	4	125	3.6	3/4	3/4	176	80
PS4000R	8800	4000	13	4	354	10	1 1/4	1 1/4	506	230
PS4000RGC	7920	3600	13	4	354	10	1 1/4	1 1/4	594	270
PS10000R	22000	10000	8	2	354	10	1 1/4	1 1/4	1408	640
PS10000RGC	22000	10000	8	2	354	10	1 1/4	1 1/4	1650	750

### Rope capacity

Recommended wire rope type: Extra Improved Plow Steel (EIPS) with IWRC

Series no.	Wire rope diameter	Full drum less 2 layers ft (m)				Full drum* ft (m)			
		Short drum		Long drum (GC)		Short drum		Long drum (GC)	
		ft.	m	ft.	m	ft.	m	ft.	m
LS150R	3/16 in. (5 mm) for rated lifting or pulling	394	120	800	244	607	185	1233	375
LS300R	1/4 in. (6.5 mm) for rated lifting or pulling	207	63	423	129	310	94	634	193
LS600R	1/4 in. (6.5 mm) for lifting or pulling	207	63	423	129	310	94	634	193
	5/16 in. (8 mm) for rated lifting or pulling	94	28	193	59	214	65	440	134
LS1500R	3/8 in. (10mm) for rated lifting or pulling	115	35	236	72	260	79	535	163
LS2000R	1/2 in. (12 mm) for lifting only	444	135	494	150	636	194	796	242
	(13 mm) for lifting only *	349	114	484	159	626	205	782	256
LS5000R	3/4 in. (19 mm) for lifting only	521	159	1099	335	747	227	1576	480
	(20 mm) for lifting only	401	131	847	278	607	199	1283	421
PS1000R	1/4 in. (6.5 mm) for pulling only	207	63	423	129	310	94	634	193
	5/16 in. (8 mm) for lifting or pulling	94	28	193	59	214	65	440	134
PS2400R	3/8 in. (10 mm) for rated lifting or pulling	115	35	236	72	260	79	535	163
PS4000R	1/2 in. (12 mm) for pulling only	444	135	494	150	636	194	796	242
	(13 mm) for pulling only *	349	114	484	159	626	205	782	256
PS10000R	3/4 in. (19 mm) for pulling only	521	159	1099	335	747	227	1576	480
	(20 mm) for pulling only	401	131	847	278	607	199	1283	421

Note: Based on 3/8 inch EIPS, IWRC wire rope. The maximum allowable ratings are: Pulling / 3414 lbs (1552 kg) and Lifting / 3020 lbs (1373 kg). See the wire rope chart in Tech Tips section for additional information.

\* Drum capacities represent tightly spooled wire rope. Recommended drum working capacity is 80% of values shown.

# Liftstar™/Pullstar™ Gear Motor Air Winch Series

## 330 to 22000 lb (150 to 10000 kg) capacity



### Dimensions:

LS150R-L, LS300R-L, LS600R-L, PS1000R-L in inches (mm). Overwound is standard.

Pendent handle in inches (mm)

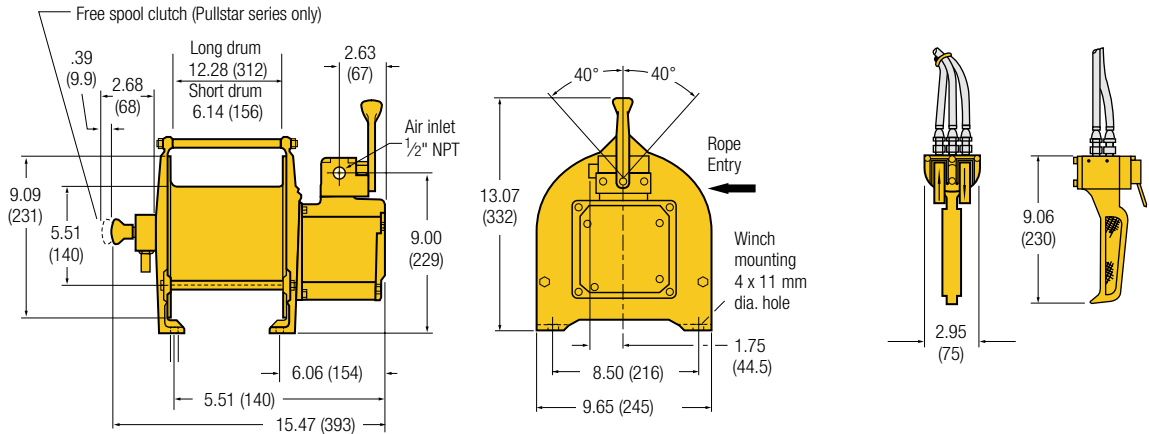

LS150R-PH2M, LS300R-PH2M, LS600R-PH2M, PS1000R-PH2M in inches (mm). Overwound is standard.

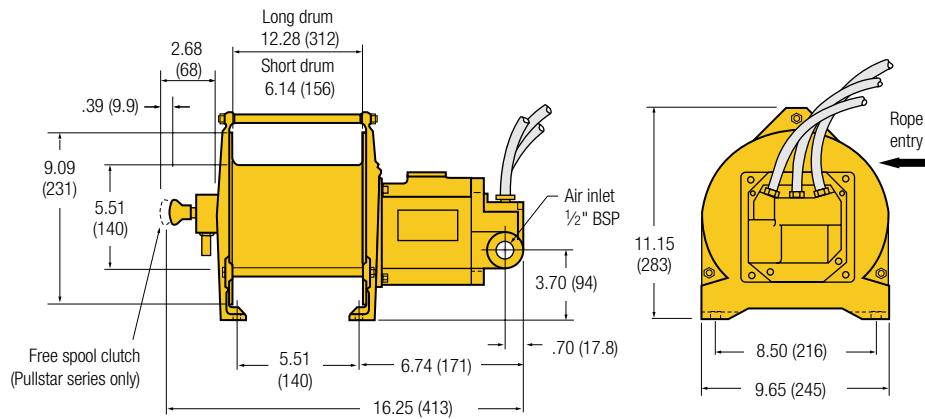

LS1500R and PS2400R in inches (mm). Underwound is standard.

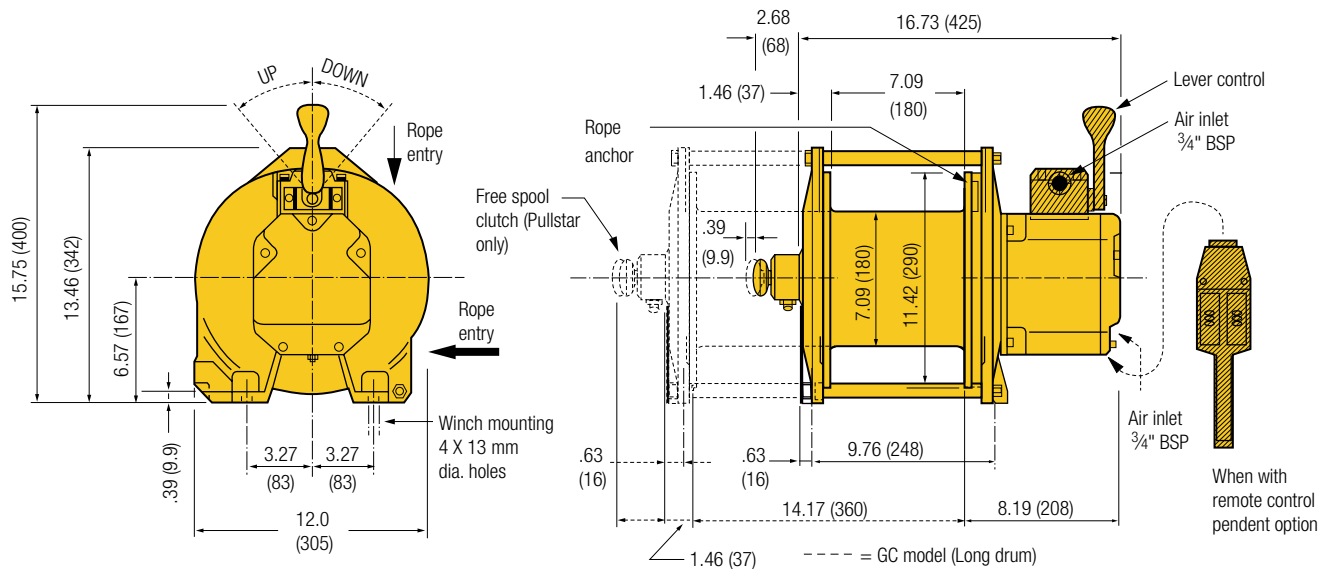

Dimensions are subject to change. Contact factory for certified prints

# Liftstar™/Pullstar™ Gear Motor Air Winch Series

330 to 22000 lb (150 to 10000 kg) capacity



## Dimensions:

LS2000R and PS4000R in inches (mm).

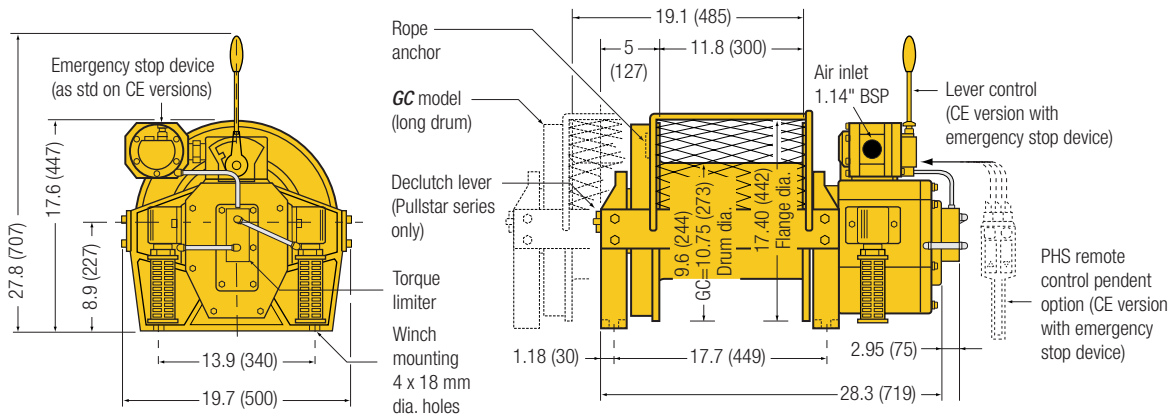

LS5000R and PS10000R in inches (mm).

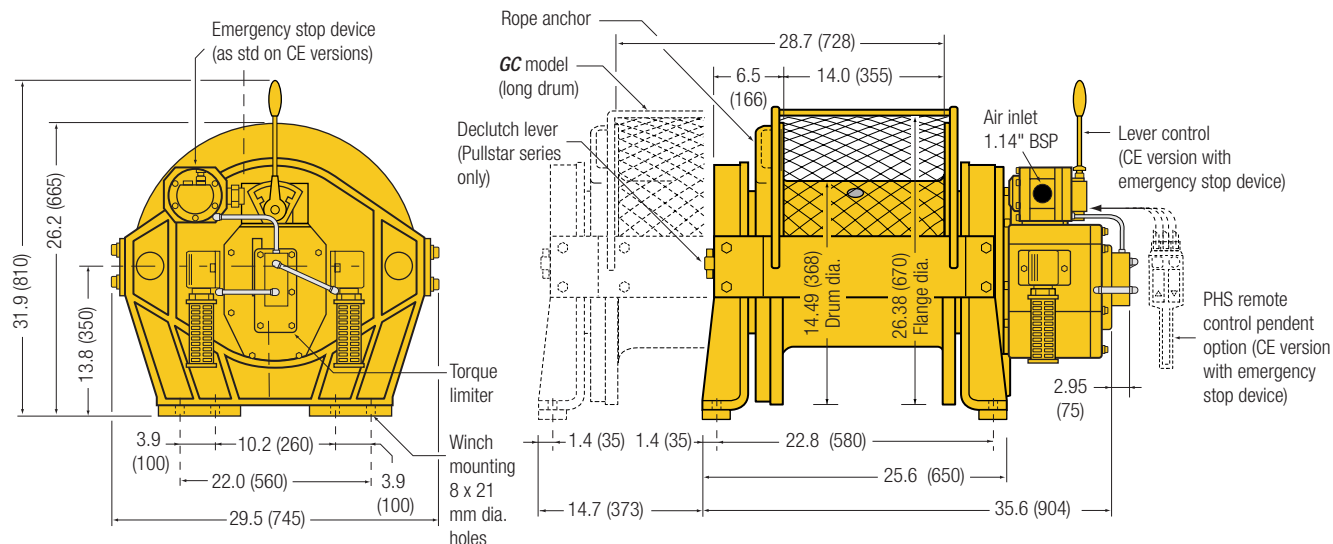

Dimensions are subject to change. Contact factory for certified prints

## How to Order

For each order specify the model code as shown below. Example: LS2400RGC-PH5M-GP

Series	Capacity	Drum	-	Control	Control length	-	Options
LS	2400R	GC	-	PH	5M	-	GP
LS = Liftstar	150R = 150 kg			L = Lever (control)			G = Drum guard
PS = Pullstar	300R = 300 kg			PH = Precision pendent, alloy, type PHS			P = Marine finish (standard surface prep, primer, marine paint)
	600R = 600 kg			PHR = Cast iron pendent			Q = Offshore paint
	1000R = 1000 kg			DP = Full flow remote control			Z = Sandblast prep and primer
	1500R = 1500 kg						
	2000R = 2000 kg						
	2400R = 2400 kg						
	4000R = 4000 kg			2M = 2 meter (standard)			
	5000R = 5000 kg			5M = 5 meter pendent			
	10000R = 10000 kg			XX = Specify control length up to 20 m			
	R = Air						
				No letter = Standard			
				GC = Long drum			

Accessories and Options	
Description	Part no.
• Lubricators (3/4 in./19 mm)	
In line bowl type	L30-06-000
Portable "can" type	50611
• Filter (3/4 in./19 mm)	F30-06-000
• Regulator (3/4 in./19 mm)	R28-06-F0G0-28
• Liquidator (3/4 in./19 mm)	8826-W2-000
• Pipeline strainer	EU-A267
• Drum guard G	
LS150R, LS300R, LS600R and PS1000R	
Short drum	7618-0057
Long drum	7618-0059
• Drum guard G LS1500R and PS2400R	
Short drum	7631-0009
Long drum	7631-0010
• Additional control hose for "PHXX" in excess of 2m	Specify in model code
• Marine paint P	Specify in model code
• Sandblast and carbozinc primer only Z	Specify in model code

# "Third Generation" Air Winch Series

## FA2B 4000 lb (1818 kg) capacity



**How do you improve on a great idea? With four significant changes over the FA2A, the FA2B takes a good idea and makes it even better.**

■ **Four changes for improved performance and reliability**

- **NEW MP150** piston motor maintains the progressive scotch yoke and adds more horsepower (16 hp). Oil free design with fewer parts and reduced vibration means easier and less frequent service. Two other piston motor options are available.
- New self-cleaning K5C2 control valve improves flow and performance. It has a primary bushing for reduced maintenance cost, more stainless steel and polymer corrosion resistant parts for smoother, more responsive control and is totally interchangeable with previous designs. 100% natural gas/sour gas compatible.
- Modified gearbox design improves efficiency and durability.
- Redesigned disc brake lowers required release pressure to 25 psig for smoother performance and no drag when air supplies are borderline.

■ **What else is new....**

- Lifting lugs
- One size fastener on the entire motor.
- Slide lift column on throttle prevents accidental movement.

■ **Options:**

- Band brakes – manual and automatic
- Drum guards
- Remote full flow and pilot controls
- Free spool clutches
- CE packages
- Grooved drums
- Divider flanges

**-E = Compliance with the European Machinery Directive. Includes as standard on utility rated winches:**

- 1 Main air supply shutoff
- 2 Overload device
- 3 Drum guard
- 4 Muffler
- 5 CE documentation



FA2B-SXK1R

- Tensioning manifolds
- Natural gas compatible; Option **R**
- HU40A (11 hp) or AMP94A (9.4 hp) motor/valve combinations
- Construction cages and open frame configurations
- Material Traceability and Type Approval Certification
- Low temperature versions
- FE2B electric and FH2B hydraulic units

■ **Why the FA2B is such good value...**

- Corrosion resistant marine grade coating system: Sandblast to white metal finish and carbozinc primer with a Marine 812 finish.
- Meets ANSI / ASME B30.16, B30.7 and has been design reviewed and approved by Det Norske Veritas. Meets European CE standards.
- Internal disc brake is oil cooled. They run and last longer. Band brakes use the latest Scanpac brake material.
- Wedge type, self tightening rope anchor provides 80% of rope breaking strength
- It is designed and built to survive some of the harshest conditions on the planet — the offshore drilling environment.

**Specifications: performance is based on 90 psi (6.3 bar) air inlet pressure with motor running**

Model number	Lift rating <sup>(1)</sup>			Pull rating <sup>(1)</sup>			Stall lbs	Stall kg	Average air cons	Recom. Ingersoll Comp.	Mtr hp	Pipe size NPT in.	Rec'd rope size in. <sup>(1)</sup>
	per ANSI / ASME B30.16 at 5:1 first	mid	top	ANSI / ASME B30.7 at 3.5:1 first	mid	top							
<b>FA2B Air Powered</b>													
Capacity lbs (kg)	5000 (2268)	4000 (1818)	3200 (1451)	5000 (2313)	4000 (1818)	3200 (1451)	6800	3084	350	P185-P375	16	1 1/4	1/2
Speed fpm (mpm)	79 (24)	96 (29)	122 (37)	79 (24)	96 (29)	122 (37)							
<b>HU40A Air Powered</b>													
Capacity lbs (kg)	5000 (2273)	4000 (1818)	3260 (1482)	7140 (3245)	5700 (2585)	4600 (2091)	11600	5273	270	P185-P375	11	1	1/2
Speed fpm (mpm)	54 (16.4)	70 (21.3)	86 (26.2)	40 (12)	49 (14.9)	60 (18.3)							
<b>AM94A Air Powered</b>													
Capacity lbs (kg)	5000 (2273)	4000 (1818)	3260 (1482)	5000 (2273)	4000 (1818)	3260 (1482)	5500	2500	320	P185-P250	9.4	1	1/2
Speed fpm (mpm)	36 (10.0)	46 (14.0)	56 (17.1)	15 (4.6)	19 (5.8)	24 (7.3)							
<b>FH2B Hydraulic Powered<sup>(2)</sup></b>													
Capacity lbs (kg)	5000 (2273)	4000 (1818)	3260 (1482)	7140 (3245)	5700 (2585)	4600 (2091)	9560	4345	gpm <sup>(3)</sup>	psig <sup>(4)</sup>	17	(7)	1/2
Speed fpm (mpm)	93 (28.3)	112 (34.1)	138 (42.1)	93 (28.3)	112 (34.1)	138 (42.1)							
<b>FE2B Electric Powered</b>													
Capacity lbs (kg)	5000 (2273)	4000 (1818)	3260 (1482)	5000 (2273)	4000 (1818)	3260 (1482)	11000	5000	amps <sup>(5)</sup>	amps <sup>(6)</sup>	15	NA	1/2
Speed fpm (mpm)	77 (23.5)	100 (30.5)	123 (37.5)	77 (23.5)	100 (30.5)	123 (37.5)							

(1) IR rates to both ANSI / ASME B30.16 (overhead hoists) and ANSI / ASME B30.7 (base mounted drum hoists). Always refer to these (or applicable) standards for details. We recommend 1/2 inch (13 mm) dia. 6 x 19 Extra Improved Plow Steel IWRC wire rope.

(2) Hydraulic winch performance is directly proportional to pressure and flow. An increase/decrease in pressure

(psig) and flow (gpm) results in an increase/decrease in capacity and speed. FH2B performance has been set within ANSI / ASME B30.16/B30.7 design criteria. This rating may be different from other hydraulic winch manufacturers. Please contact technical sales with application/performance requirements.

(3) Flow (25 gpm).

(4) Pressure (psig), 1850 lifting, 2350 pulling.

(5) Full load current, 19 amps @ 460V.

(6) Max current draw (locked rotor), 110 amps @ 460V.

(7) SAE-12 JIC

# "Third Generation" Air Winch Series

## FA2B 4000 lb (1818 kg) capacity



### Rope storage capacities <sup>(1)</sup> (all versions)

Drum capacities represent tightly spooled wire rope. Recommended drum working capacity is 80% of values shown.

Drum length in. mm	Full drum less 1/2" (13 mm) <sup>(2)</sup> Wire rope diameter								Full drum storage Wire rope diameter							
	3/8" (10 mm)		7/16" (11 mm)		1/2" (13 mm)		5/8" (16 mm)		3/8" (10 mm)		7/16" (11 mm)		1/2" (13 mm)		5/8" (16 mm)	
	ft	m	ft	m	ft	m	ft	m	ft	m	ft	m	ft	m	ft	m
7 178	519	158	396	120	300	91	164	50	593	180	460	140	356	108	206	62
13 1/2 343	1029	314	788	240	600	183	330	100	1176	358	915	279	712	217	416	126
20 508	1538	468	1180	360	900	274	497	151	1758	535	1371	417	1068	325	625	190
24 610	1852	564	1421	433	1085	331	600	183	2116	645	1651	503	1287	392	754	230

(1) For allowable rope takeoff angles. See illustrations below.

(2) Per ANSI / ASME B30.7

**Typical allowable wire rope takeoff angle:** Shaded areas represent the allowable angle of rope takeoff without interference with the winch's structural supports.

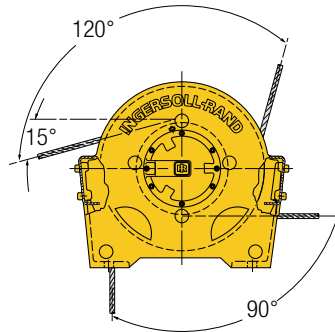

Standard Configuration

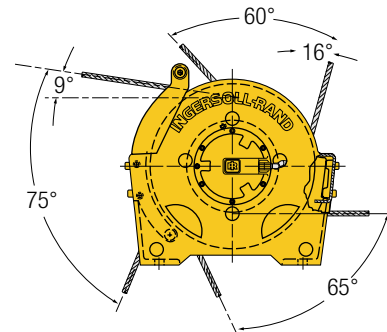

Open Front Configuration (Option H)

### Dimensions

Model number	Type of drum brk.	Auto disc brk.	A		FA2B only B		HU40A only B		C		D	
			in.	mm	in.	mm	in.	mm	in.	mm	in.	mm
FA2B- / HU40A- SXX1	None	Yes	7.0	178	34.7	881	33.8	859	9.6	244	4.8	122
FA2B- / HU40A- MXK1	None	Yes	13.5	343	41.2	1046	40.3	1024	16.1	409	8.0	203
FA2B- / HU40A- LXX1	None	Yes	20.0	508	47.7	1212	46.8	1189	22.6	574	11.3	287
FA2B- / HU40A- RXK1	None	Yes	24.0	610	51.7	1313	50.8	1290	26.6	676	13.3	338
FA2B- / HU40A- SMK1 (SAK1)	Manual (automatic)	Yes	7.0	178	37.4	950	36.5	927	12.3	312	7.5	191
FA2B- / HU40A- MMK1 (MAK1)	Manual (automatic)	Yes	13.5	343	43.9	1115	43.0	1092	18.8	478	10.8	274
FA2B- / HU40A- LMK1 (LAK1)	Manual (automatic)	Yes	20.0	508	50.4	1280	59.5	1257	25.3	643	14.0	356
FA2B- / HU40A- RMK1 (RAK1)	Manual (automatic)	Yes	24.0	610	54.4	1382	53.5	1359	29.3	744	16.0	406
FA2B- / HU40A- SMX1 (SAX1)	Manual (automatic)	No	7.0	178	34.1	866	33.2	843	12.3	312	7.5	191
FA2B- / HU40A- MMX1 (MAX1)	Manual (automatic)	No	13.5	343	40.6	1031	39.7	1008	18.8	478	10.8	274
FA2B- / HU40A- LMX1 (LAX1)	Manual (automatic)	No	20.0	508	47.1	1196	46.2	1173	25.3	643	14.0	356
FA2B- / HU40A- RMX1 (RAX1)	Manual (automatic)	No	24.0	610	51.1	1298	50.2	1275	29.3	744	16.0	406

### FA2B / HU40A in inches (mm)

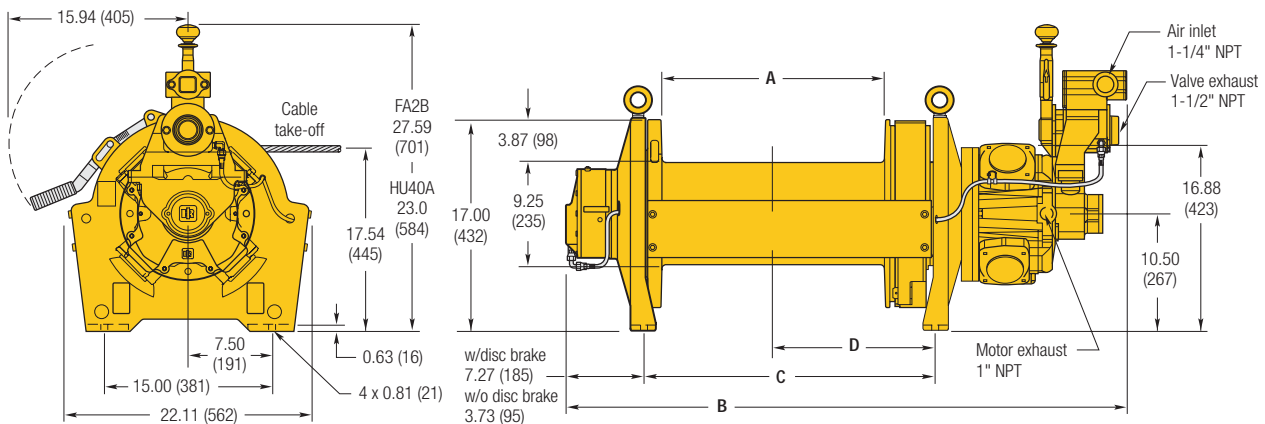

Dimensions are subject to change. Contact factory for certified prints



# "Third Generation" Air Winch Series

## FA2B 4000 lb (1818 kg) capacity



### How to Order:

Specify by complete model code as illustrated. **Example: FA2B-LXK1G** = 4000 lb (1818 kg) capacity, long drum, auto disc brake, winch mounted lever control, and drum guard.

Series	Capacity	Generation	-	Drum length	Drum brake	Disc brake	Control	Options		
<b>FA</b>	<b>2</b>	<b>B</b>	<b>-</b>	<b>L</b>	<b>X</b>	<b>K</b>	<b>1</b>	<b>G</b>		
	2 = 2 ton (4000 lbs)	B = Third generation		S = Short M = Medium L = Long R = Extra long Note: See drum length matrix below	A = Auto drum brake M = Manual drum brake X = No drum brake	X = No auto disc brake K = Auto disc brake		7 = Drum grooving (specify rope size in sixteenths, e.g. 7 = 7/16") B = Press roller (specify takeoff angles) C = Low temperature; please specify in text: -10° C or -20° C D = Drum divider flange and additional cable anchor E = Construction cage F = Free spool clutch <sup>(2)</sup> G = Drum guard H = Open frame for horizontal pulling M1 = Per DIN 50049/En10204 Para 2.2 "Typicals" <sup>(3)</sup> M2 = Per DIN 50049/En10204 Para 3.1b actual per product as purchased <sup>(3)</sup> M3 = Per DIN 50049/En10204 Para 3.1b actual per product as delivered in final condition <sup>(3)</sup> N = Type approval; please specify in text DNV, ABS or Lloyds P = Marine 812 finish Q = Special paint; please specify R = Suitable for operation with natural gas with up to 4 percent sulphur content T = Tension manifold U = Underwound (available only with auto disc brake <b>XK</b> ) W = Witness; please specify X = Testing; please specify Z = Sandblast and carbozinc primer only -E = Compliance w/European Machinery Directive		
<p><b>FA</b> = Air powered HU40A* AMP94A* * = Substitute for FA2B FE = Electric powered FH = Hydraulic powered</p>										
<p>(1) With remote pilot control option, line speeds will decrease. (2) Only available with manual drum brake. (3) Documentation, witness testing and material traceability available; must be requested at time of order. Specify options or contact factory or your nearest Ingersoll-Rand distributor for information.</p> <p><b>M1</b> Material traceability certificates according to EN 10204 (Ex DIN 50049) 2.2 on load bearing parts. This conformity document affirms (by the manufacturer) that parts are in compliance with the requirements of the order based on non-specific inspection and testing (i.e. results are typical material properties for these parts.) <b>M2</b> Material traceability certificates according to EN 10204 (Ex DIN 50049) 3.1b on load bearing parts. These documents affirm (by a department independent of the manufacturing department) that the actual parts used in the product are in compliance with the order based on specific inspection and testing (i.e. results are actual material properties for those parts.) <b>M3</b> Material traceability certificates according to EN 10204 (Ex DIN 50049) 3.1b on load bearing parts. These documents affirm (by a department independent of the manufacturing department) that the actual parts used in the product are in compliance with the order based on specific inspection and testing (i.e. results are actual material properties for those parts in a finished, as delivered condition.)</p>										
					1 = Standard winch mounted throttle	2XX = Remote full flow lever throttle (max 20 ft/6 m)	3XX = Remote pilot pendent throttle (std = 6 ft/1.8 m; max 66 ft/20 m) <sup>(1)</sup>	4XX = Remote pilot lever throttle (max 66 ft/20 m) <sup>(1)</sup>	5XX = Remote electric over air throttle	XX = Specify hose length or pendent cord in feet

## "Third Generation" Air Winch Series

FA2.5A/FA5A: 5000 to 10000 lb (2273 to 4545 kg) capacity



The Third Generation Force 5 Series is designed for world-wide standards, meeting or exceeding North American ANSI / ASME B30.7 winch standards, CE requirements for Europe and third party Type Approval. The Third Generation offers standard features with reduced maintenance for safety, durability, reliability, enhanced control, and superior performance.

### Standard features:

- Automatic disc brake or manual band brake
- Corrosion resistant, marine duty "Blue" fasteners
- New self-cleaning K5C2 control valve improves flow and performance, has more stainless steel and polymer corrosion resistant parts, and is totally interchangeable with previous designs. 100% natural gas/sour gas compatible.
- Easy to install wedge type self-tightening rope anchor
- Powerful 5 piston air motor.

### Safety is Built In:

- Meets ASME B30.7 safety standards
- "Lift and shift" throttle lever prevents accidental throttle movement
- Throttle lever returns to OFF position and locks when released
- Disc brake is fully automatic and self-adjusting
- Wedge type, self tightening-rope anchor provides 80% of rope breaking strength

### Reliability

- Maximum external corrosion protection against marine and other environments is provided as standard.
- Automatic oil bath disc brake has high thermal duty. Suitable for demanding applications.
- Marine grade alloys and stainless steel components make the valve chest corrosion resistant and maintenance free.

### Performance

- Superior load spotting control
- Positive braking action with automatic disc brake



FA5A-LXK1

### Construction

- Designed to meet the space and performance requirements of the Classic winches

### Options

- Corrosion resistant marine grade coating system: Sandblast to white metal finish and carbozinc primer with a Marine 812 finish
- Band brakes – manual and automatic
- Remote controls
- Construction cages
- Open frame configurations
- Foot print base with K6U and K6UL bolt pattern for FA5A
- Free spool clutch
- Tensioning manifold
- Drum guard
- Underwound configuration
- CE package

**-E = Compliance with the European Machinery Directive. Includes as standard on utility rated winches:**

- 1 Main air supply shutoff
- 2 Overload device
- 3 Drum guard
- 4 Muffler
- 5 CE documentation

### Specifications\*

Description	FA2.5A		FA5A	
	5000 lbs	2273 kg	10000 lbs	4545 kg
Rated mid layer line pull, 5:1 DF	5000 lbs	2273 kg	10000 lbs	4545 kg
Rated mid layer line speed	114 fpm	35 m/min	32 fpm	10 m/min
Top (6th) layer line pull, 5:1 DF	4100 lbs	1860 kg	8000 lbs	3629 kg
Top (6th) layer line speed	141 fpm	43 m/min	43 fpm	13 m/min
Max. stall at first layer	10400 lbs	4727 kg	17000 lbs	7727 kg
Drum root diameter	9.25 in.	235 mm	12.75 in.	324 mm
Motor horsepower	25 hp		25 hp	
Avg air consumption	700 scfm	20 m <sup>3</sup> /min	700 scfm	20 m <sup>3</sup> /min
Air inlet, NPT size	1 1/4 in.	32 mm	1 1/4 in.	32 mm
Recommended rope diameter	5/8 in.	16 mm	3/4 in.	19 mm
Weight	818 lbs	372 kg	1251 lbs	569 kg

\* Performance is based on 90 psi (6.3 bar) air inlet pressure with the motor running.

### Wire rope storage capacity

Rope dia in. mm	Length of drum in. (mm)								
	S 7 (178)		M 13 1/2 (343)		L 20 (508)		R 24 (610)		
	ft	m	ft	m	ft	m	ft	m	
<b>FA2.5A full drum storage</b>									
3/8	9	593	181	1176	359	1758	536	2116	645
7/16	11	460	140	915	279	1371	418	1651	503
1/2	13	356	109	712	217	1068	326	1287	392
5/8	16	206	63	416	127	625	191	754	230
<b>Short drum                      Long drum</b>									
<b>12 (305) <sup>(1)</sup>                      15 (381) <sup>(2)</sup>                      24 (610) <sup>(1)</sup>                      27 (686) <sup>(2)</sup></b>									
<b>FA5A full drum storage</b>									
5/8	16	777	236	982	299	1597	486	1802	549
3/4	19	581	177	736	224	1200	366	1355	413

(1) With band brake

(2) Without band brake

Recommended drum working capacity is 80% of values shown.

**“Third Generation” Air Winch Series**  
**FA2.5A/FA5A: 5000 to 10000 lb (2273 to 4545 kg) capacity**



**Dimensions: FA2.5A**

Model	Drum length		w/disc brake only				w/manual drum brake only				w/manual and disc brake									
	A		B		C		B		C		B		C		D					
	in.	mm	in.	mm	in.	mm	in.	mm	in.	mm	in.	mm	in.	mm	in.	mm				
FA2.5A-S	7	178	38.44	976	9.55	243	4.78	121	37.64	956	12.31	313	7.5	191	41.19	1046	12.31	313	7.5	191
FA2.5A-M	13.5	343	44.94	1141	16.05	408	8.03	204	44.14	1121	18.81	478	10.8	274	47.69	1211	18.81	478	10.8	274
FA2.5A-L	20	508	51.44	1306	22.55	573	11.28	286	50.64	1286	25.31	643	14	356	54.19	1376	25.31	643	14	356
FA2.5A-R	24	610	55.44	1408	26.55	674	13.28	337	54.64	1388	29.31	744	16	406	58.19	1478	29.31	744	16	406

**Dimensions: FA5A**

FA5A-SX	15	381	46.50	1181	17.89	454	8.94	227	43	1092	17.89	454	10.5	266	46.5	1181	17.89	454	10.5	266
FA5A-LX	27	686	58.50	1486	29.89	759	14.94	379	55	1397	29.89	759	16.5	419	58.5	1486	29.89	759	16.5	419

Note: Drum lengths for the FA5A-SM = 12 in. (305), and FA5A-LM = 24 in. (610 mm).

**FA2.5A in inches (mm)**

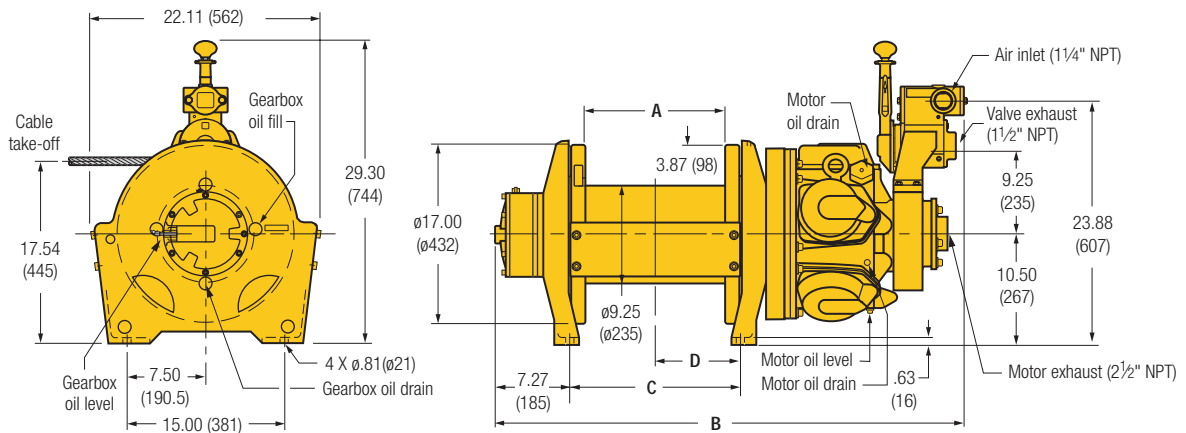

**FA5A in inches (mm)**

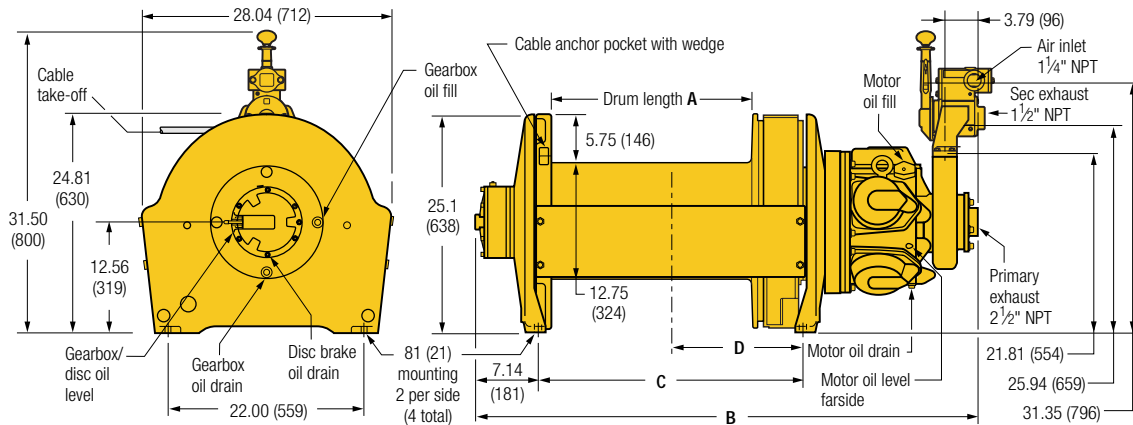

Dimensions are subject to change. Contact factory for certified prints

**Typical allowable wire rope takeoff angle:** Shaded areas represent allowable angle of rope takeoff without interference with winch structural supports.

**for FA2.5A**

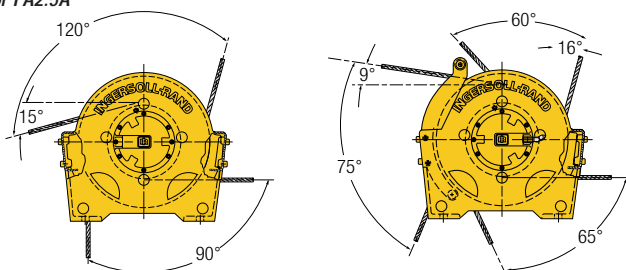

**for FA5A**

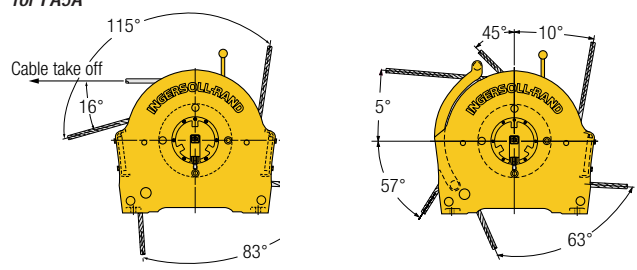

Standard Configuration

Open Front Configuration (Option H)

Standard Configuration

Open Front Configuration (Option H)

# "Third Generation" Air Winch Series

## FA2.5A/FA5A: 5000 to 10000 lb (2273 to 4545 kg) capacity



### How to Order:

Specify winch by complete model code as shown.

**Example:** FA5A-LXK1G = 10000 lb (4545 kg) capacity, 27" (686 mm) drum, auto disc brake, throttle-control and drum guard.

Series	Capacity	Generation	-	Drum length	Drum brake	Disc brake	Control	Options
FA	5	A	-	L	X	K	1	G
	2.5 = 2.5 ton (5000 lbs) 5 = 5 ton (10000 lbs)	A = Third generation		S = Short M = Medium L = Long R = Extra long Note: See drum length matrix below	A = Auto drum brake M = Manual drum brake X = No drum brake	X = No auto disc brake K = Auto disc brake		7 = Drum grooving (specify rope size in sixteenths, e.g. 7 = 7/16") C = Low temperature; please specify in text: -10° C or -20° C D = Drum divider flange and additional cable anchor E = Construction cage F = Free spool clutch <sup>(2)</sup> G = Drum guard H = Open frame for horizontal pulling K = K6 footprint base for FA5A M1 = Per DIN 50049/En10204 Para 2.2 "Typicals" <sup>(3)</sup> M2 = Per DIN 50049/En10204 Para 3.1b actual per product as purchased <sup>(3)</sup> M3 = Per DIN 50049/En10204 Para 3.1b actual per product as delivered in final condition <sup>(3)</sup> N = Type approval; please specify in text DNV, ABS or Lloyds P = Marine 812 finish Q = Special paint; please specify T = Tension manifold U = Underwound (available only with auto disc brake <b>XX</b> ) V = Press roller (specify takeoff angles) W = Witness; please specify X = Testing; please specify Z = Sandblast and carbozinc primer only -E = Compliance with the European Machinery Directive
	FA = Air powered							

FA2.5A Drum length					
Length of drum	Drum brake				
	without		with		
	in.	mm	in.	mm	
S	7	178	7	178	
M	13 1/2	343	13 1/2	343	
L	20	508	20	508	
R	24	610	24	610	

FA5A Drum length					
Length of drum	Drum brake				
	without		with		
	in.	mm	in.	mm	
S	15	381	12	305	
L	27	686	24	610	

1 = Standard winch mounted throttle	2XX = Remote full flow lever throttle (max 20 ft/6 m)	3XX = Remote pilot pendent throttle (std = 6 ft/1.8 m; max 66 ft/20 m) <sup>(1)</sup>	4XX = Remote pilot lever throttle (max 66 ft/20 m) <sup>(1)</sup>	5XX = Remote electric over air throttle	XX = Specify hose length or pendent cord in feet
-------------------------------------	---	---	---	---	--

(1) With remote pilot control option, line speeds will decrease.  
(2) Only available with manual drum brake.  
(3) Documentation, witness testing and material traceability available; must be requested at time of order. Specify options or contact factory or your nearest Ingersoll-Rand distributor for information.

**M1** Material traceability certificates according to EN 10204 (Ex DIN 50049) 2.2 on load bearing parts. This conformity document affirms (by the manufacturer) that parts are in compliance with the requirements of the order based on non-specific inspection and testing (i.e. results are typical material properties for these parts.)

**M2** Material traceability certificates according to EN 10204 (Ex DIN 50049) 3.1b on load bearing parts. These documents affirm (by a department independent of the manufacturing department) that the actual parts used in the product are in compliance with the order based on specific inspection and testing (i.e. results are actual material properties for those parts.)

**M3** Material traceability certificates according to EN 10204 (Ex DIN 50049) 3.1b on load bearing parts. These documents affirm (by a department independent of the manufacturing department) that the actual parts used in the product are in compliance with the order based on specific inspection and testing (i.e. results are actual material properties for those parts in a finished, as delivered condition.)

## Force 5™ Air Winch Series 4400 to 22000 lb (2000 to 10000 kg) capacity



Setting the standards in winch technology with time savings, space savings and enhanced safety, IR's line of high quality Force 5 air winches are known throughout the world for their rugged dependability and quality in the hard-hat industries.

### ■ Your assurance of quality:

Force 5 winches are designed to meet or exceed independent third party requirements. Models have been design reviewed or Type Approved by ABS, DNV and LRS. Type Approval certificates are available upon request. This modern winch is designed for the harshest environments!

### ■ Versatility:

Force 5 winches offer maximum versatility to meet numerous lifting, pulling, or tensioning challenges. Substitute a wide variety of gear ratios to better meet **your** speed and capacity needs. Design, material, and dimensional changes are a snap with fabricated frames. Available option packages meet the requirements of oil refineries, mining, construction and offshore oil drilling.

### ■ Standard features:

- Meets ASME B30.7
- 5:1 design factor at rated load
- Full drum rated line pull: a Force 5 winch always pulls or lifts its rated load at any and all wire rope layers.
- Internal gearbox and optional disc brake combination provide load control superior to other types of air winches.
- Compact, space-saving frame design and fabricated alloy steel drum fit easily into tight spaces
- Variable drum length and wire rope storage for special applications
- Standard operating temperature range is 0°C through 60°C.
- Minimum 18:1 drum diameter to wire rope diameter ratio reduces wire rope wear.
- Longer drum lengths and taller flanges provide greater wire rope storage

### ■ Options and accessories:

- Optional enclosed oil bath "wet" disc brake is fully sealed for protection against salt spray, dirt and moisture, providing trouble-free operation over thousands of lifting cycles. A disc brake is standard on the FA10.
- Automatic band brakes
- Variable drum lengths 8" to 50" (203 to 1067 mm)



FA5

- Grooved drums
- Drum divider flange
- Drum guard
- Limit switch
- Drum lock
- Construction cage
- Corrosion resistant marine grade coating system: sandblast to white metal finish and carbozinc primer with a Marine 812 finish
- Tensioning manifold
- Air preparation packages: filter, regulator, lubricator, liquidator, and strainer
- Electric over air remote control allows for virtually unlimited pendent length
- Air operated remote controls
- Muffler
- Hydraulic models
- Third party certifications for low temperature applications
- Special winches for refinery decoking applications
- FA7T Guideline (GL) and Podline (PL) winches feature 42" drums, drum locking dogs and marine grade finishes, materials and fasteners. The GL version offers dual controls, and is designed to overhaul. For performance and specification detail, see chart on the following page.

**Force 5™ Air Winch Series**  
**4400 to 22000 lb (2000 to 10000 kg) capacity**



**Specifications: performance is based on 90 psi (6.3 bar) air inlet pressure with motor running**

Model no.	Utility rating 5:1 design factor		top layer		Drum length			Avg. air consumption		Maximum stall pull		Pipe inlet size		Hose size		Ship weight	
	line pull	line speed	top layer	top layer	A		hp	@ 90 psi (6.3 bar)		1st layer							
	lbs	kg	fpm	m/min	in.	mm		scfm	m <sup>3</sup> /min	lbs	kg	in.	mm	in.	mm	lbs	kg
FA2-24	4400	2000	47	14	24	610	9.4	335	9.5	9000	4091	1 1/4	32	1 1/4	32	825	374
FA2.5-24	5000	2273	132	40	24	610	25	700	19.9	10000	4545	1 1/4	32	1 1/2	38	1061	481
FA5-24	11000	5000	54	16	24	610	25	700	19.9	24000	10909	1 1/4	32	1 1/2	38	1872	849
FA5T-24	8400	3818	70	21	24	610	25	700	19.9	24000	10909	1 1/4	32	1 1/2	38	2153	977
FA7-24	15400	7000	40	12	24	610	25	750	21.3	36000	16364	1 1/4	32	1 1/2	38	2205	1000
FA7T-24	12600	5727	48	15	24	610	25	750	21.3	36000	16364	1 1/4	32	1 1/2	38	2335	1059
FA7TGL-42	3400	1545	152	46	42	1067	25	750	21.3	10000	4545	1 1/4	32	1 1/2	38	2981	1352
FA7TPL-42	10200	4636	60	18	42	1067	25	750	21.3	36000	16364	1 1/4	32	1 1/2	38	2850	1293
FA10-24	22000	10000	23	7	24	610	31	800	22.7	38000	17273	1 1/4	32	1 1/2	38	3200	1451

Note: Adding "-E" to model states compliance with European Machinery Directive. See the Air Winch Selection Guide for explanation of compliance.

**Drum wire rope storage capacities<sup>(1)</sup>**

Model	Capacity		Recommended wire rope size		Drum length		Rope diameter														
	lbs	kg	in.	mm	in.	mm	1/2" (13 mm)		5/8" (16 mm)		3/4" (19 mm)		7/8" (22 mm)		1" (25 mm)		1 1/8" (29 mm)				
							ft	m	ft	m	ft	m	ft	m	ft	m	ft	m			
FA2	4400	2000	1/2	13 mm	8	203	388	118	266	81											
					12	305	594	181	410	125											
					16	406	801	244	554	169											
					24	610	1214	370	843	257											
FA2.5	5000	2273	5/8	16 mm	8	203			266	81											
					12	305			410	125											
					16	406			554	169											
					24	610			843	259											
FA5	11000	5000	3/4	19 mm	16	406			1181	360	746	227	544	166							
					24	610			1795	547	1138	347	832	254							
					30	762			2256	688	1431	433	1047	319							
					36	915					1682	512	1204	367							
FA5T	8400	3818	3/4	19 mm	24	610					2564	761	1841	561							
					30	762					3225	983	2318	706							
					36	915					3887	1185	2796	852							
					24	610					1640	500	1059	323	786	240					
FA7	15400	7000	7/8	22 mm	30	762					2063	629	1334	406	991	302					
					36	915					2486	758	1608	493	1196	365					
					24	610					2669	813	1917	584	1538	469					
					30	762					3358	1023	2414	736	1940	591					
FA7T	12600	5727	7/8	22 mm	36	915					4047	1233	2912	887	2311	713					
					42	1067					4736	1443	3409	1039	2742	836					
					24	610					2488	758	1962	598	1332	405	1026	313			
					30	762					3130	954	2471	753	1679	511	1295	395			
FA10	22000	10000	1 1/8	29 mm	36	915					3773	1150	2980	908	2027	617	1564	477			
					40	1016					4201	1280	3319	1011	2258	688	1744	531			
					50	1270					5271	1606	4168	1270	2837	865	2192	668			
					24	610															

(1) Capacities meet ANSI-ASME B30.7 which requires 1/2" (13 mm) minimum clear flange above last layer. Capacities represent tightly wound wire rope. Recommended working capacity is 80% of values shown.

# Force 5™ Air Winch Series

4400 to 22000 lb (2000 to 10000 kg) capacity



## Dimensions

FA2-24 with disc and band brakes or band brake only in inches (mm)

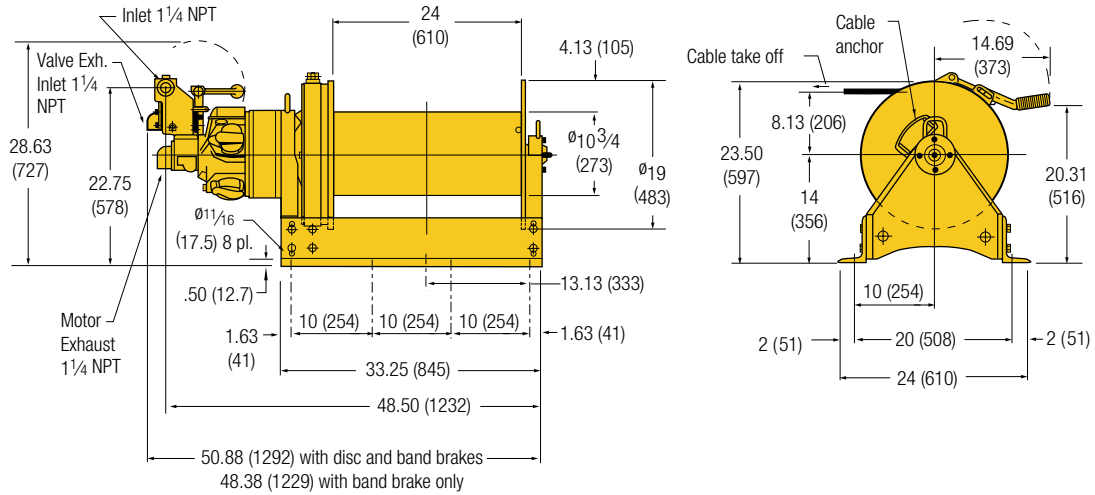

FA2-24 with disc brake only in inches (mm)

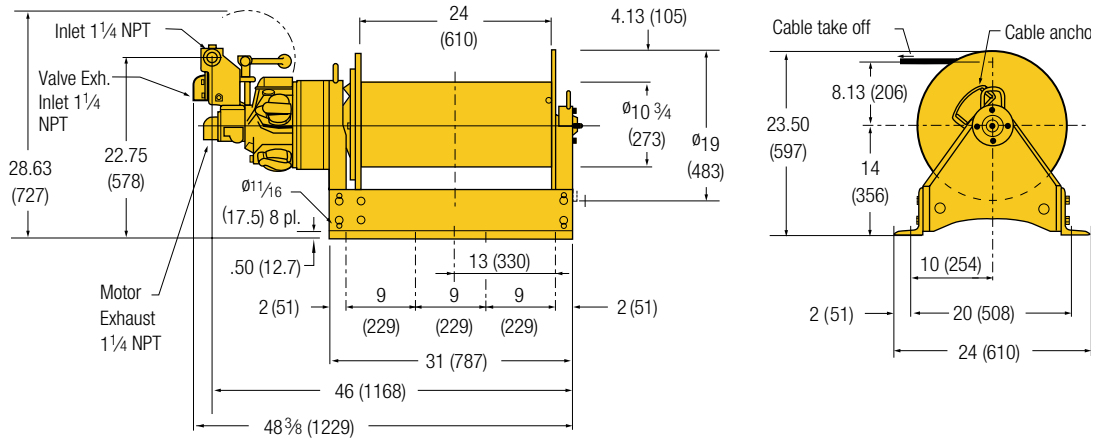

FA2.5-24 with disc and band brakes or band brake only in inches (mm)

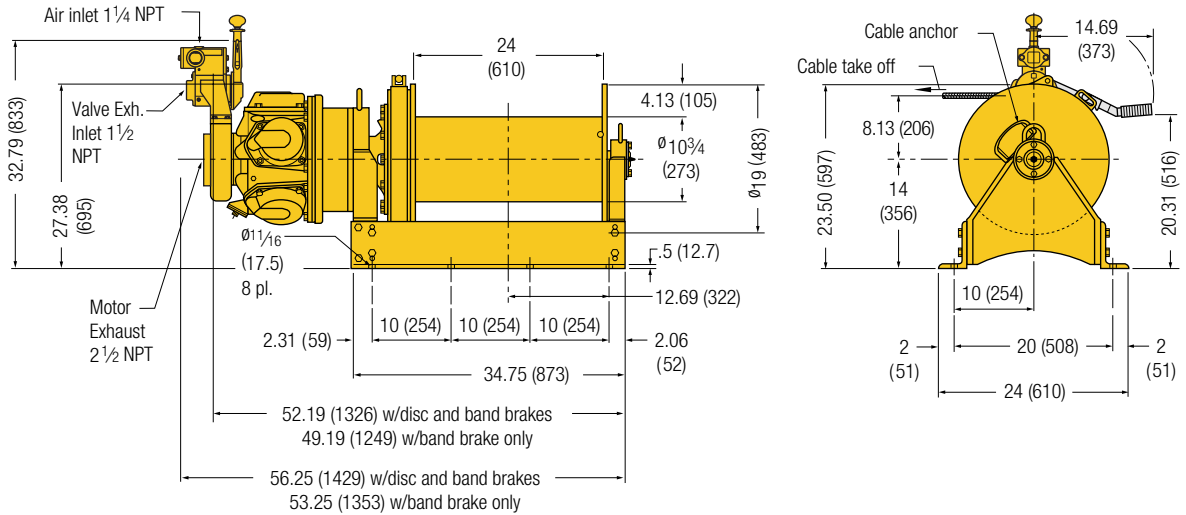

Dimensions are subject to change. Contact factory for certified prints

**Force 5™ Air Winch Series**  
**4400 to 22000 lb (2000 to 10000 kg) capacity**



**Dimensions**

**FA2.5-24 with disc brake only in inches (mm)**

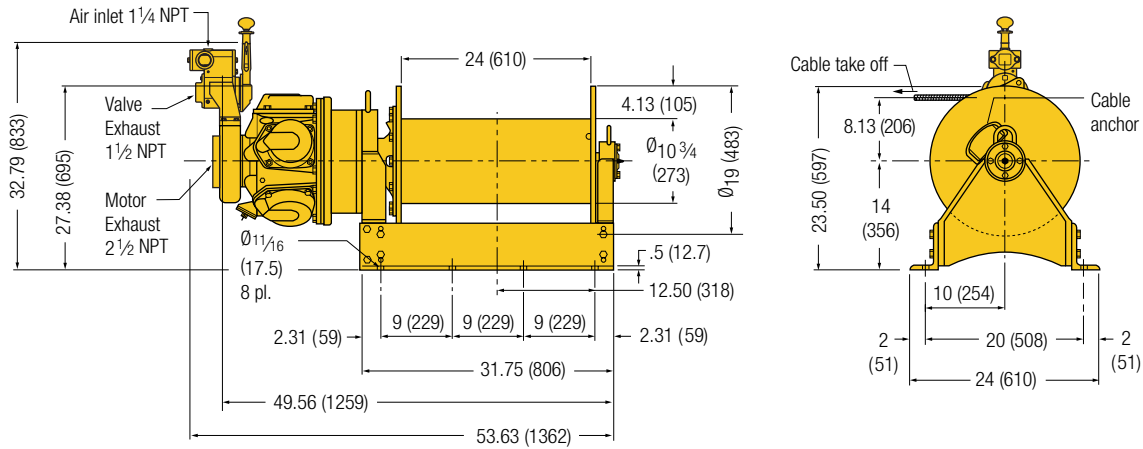

**FA5-24 with disc and band brakes or band brake only in inches (mm)**

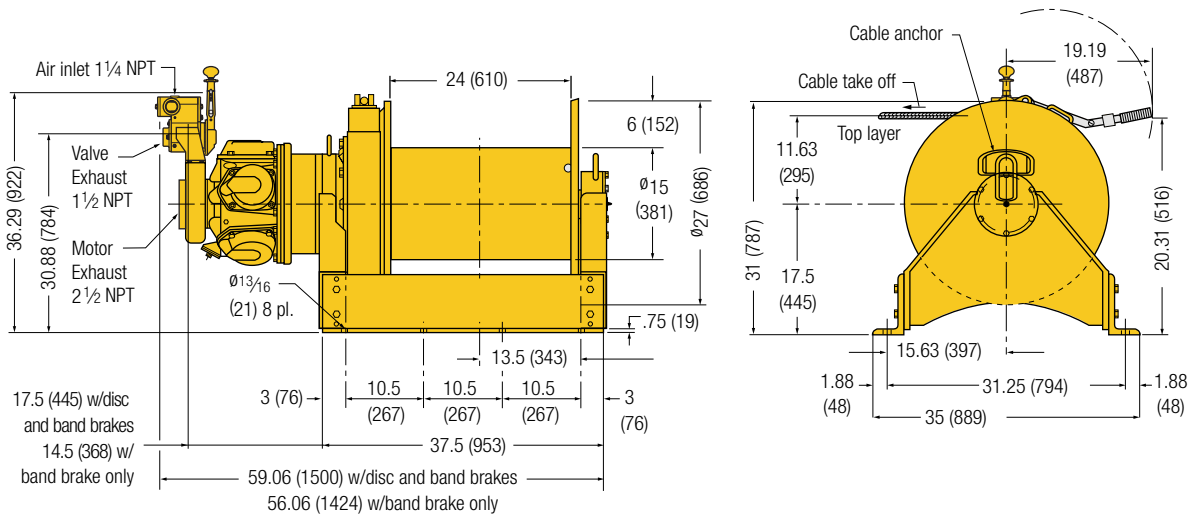

**FA5-24 with disc brake only in inches (mm)**

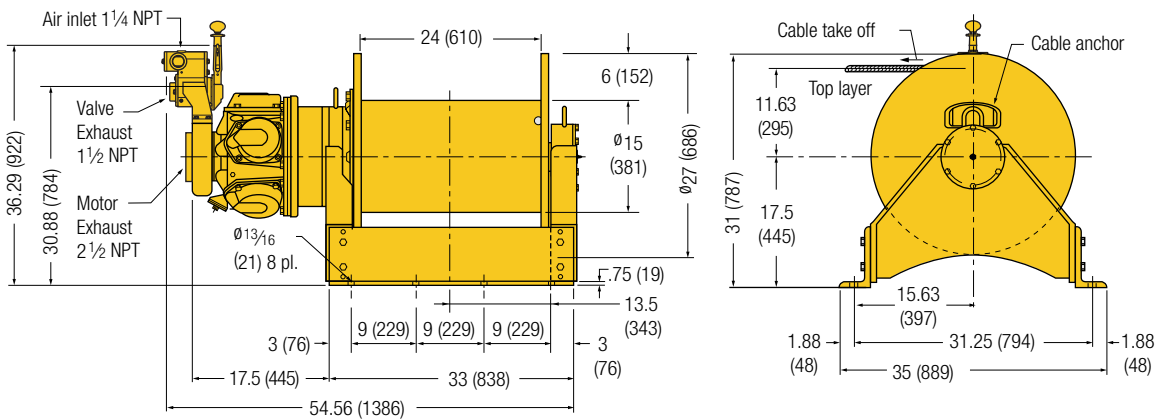

Dimensions are subject to change. Contact factory for certified prints



# Force 5™ Air Winch Series

4400 to 22000 lb (2000 to 10000 kg) capacity



## Dimensions

FA5T-24 with disc and band brakes or band brake only in inches (mm)

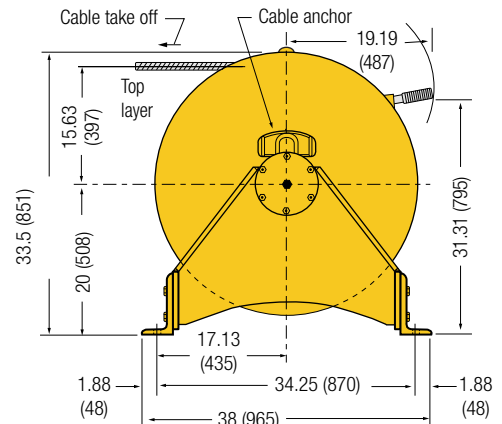
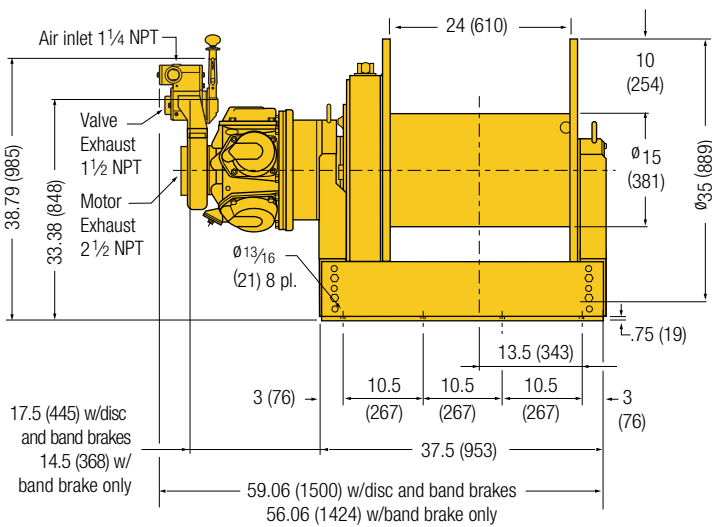

FA5T-24 with disc brake only in inches (mm)

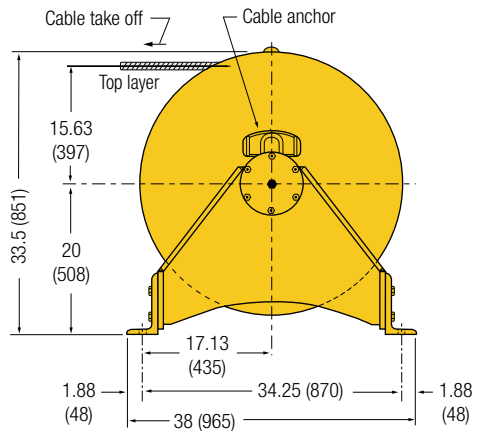
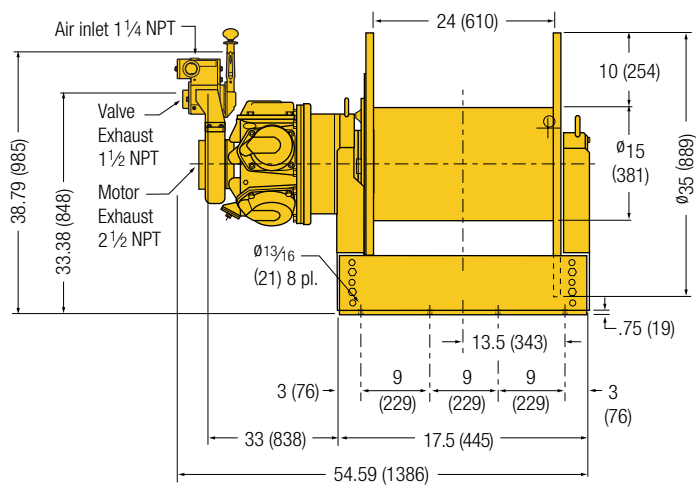

FA7-24 – Popeye Junior – with disc and band brakes or band brake only in inches (mm)

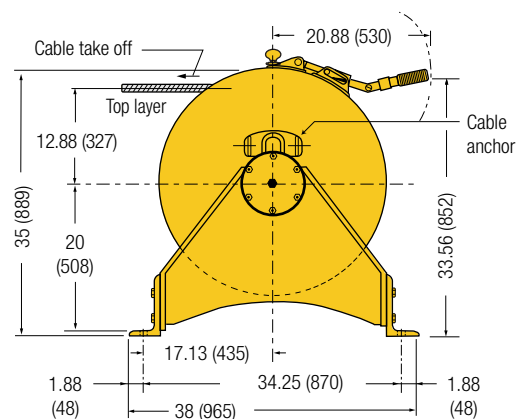
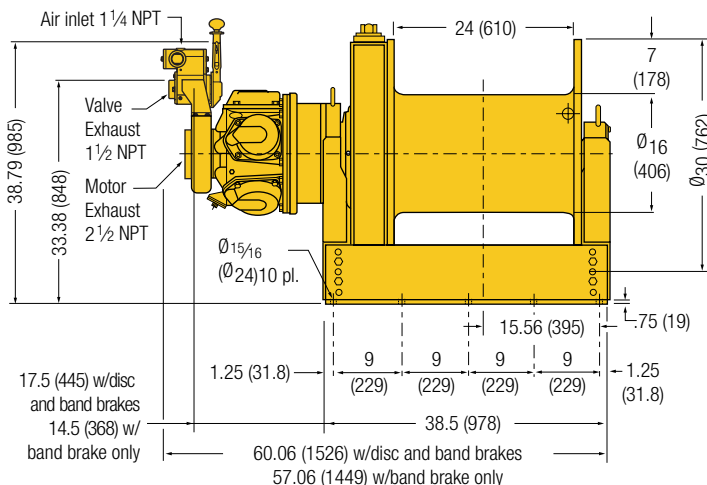

Dimensions are subject to change. Contact factory for certified prints

**Force 5™ Air Winch Series**  
**4400 to 22000 lb (2000 to 10000 kg) capacity**



**Dimensions**

**FA7-24 – Popeye Junior – with disc brake only in inches (mm)**

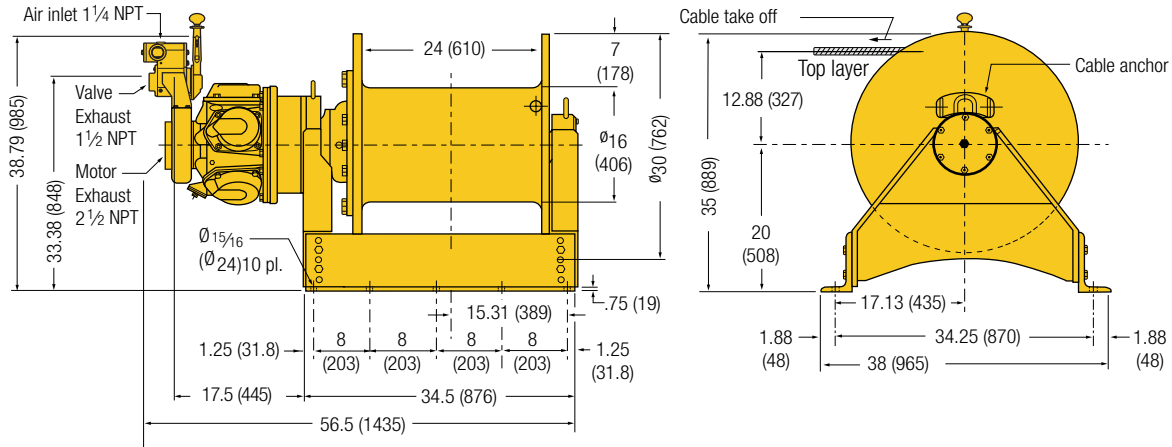

**FA7T-24 – Popeye Junior – with disc and band brakes or band brake only in inches (mm)**

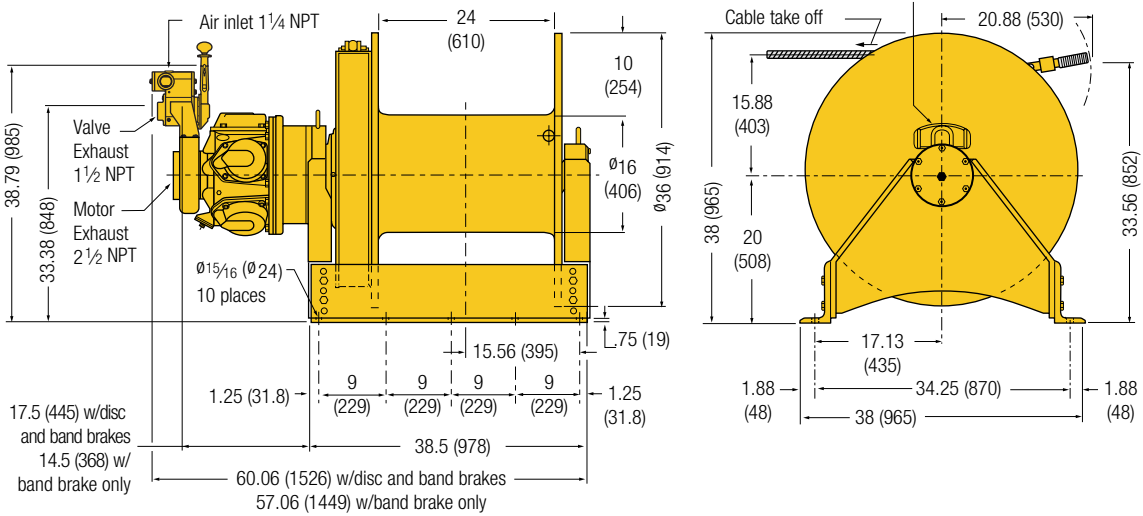

**FA7T-24 – Popeye Junior – with disc brake only in inches (mm)**

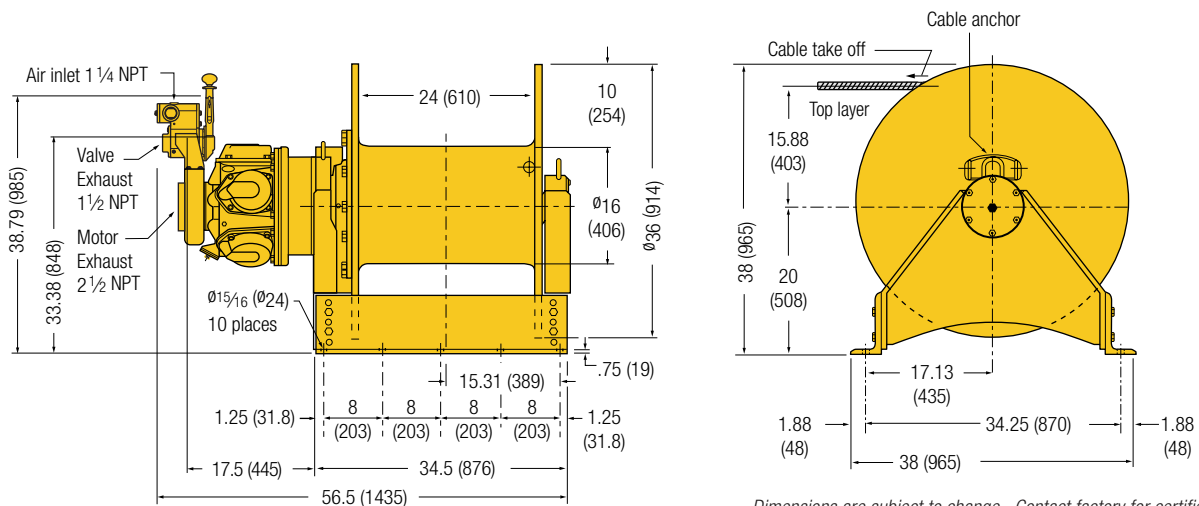

Dimensions are subject to change. Contact factory for certified prints

**Force 5™ Air Winch Series**  
**4400 to 22000 lb (2000 to 10000 kg) capacity**



**Dimensions**

**FA10-24 – Popeye – with disc and band brakes or band brake only in inches (mm)**

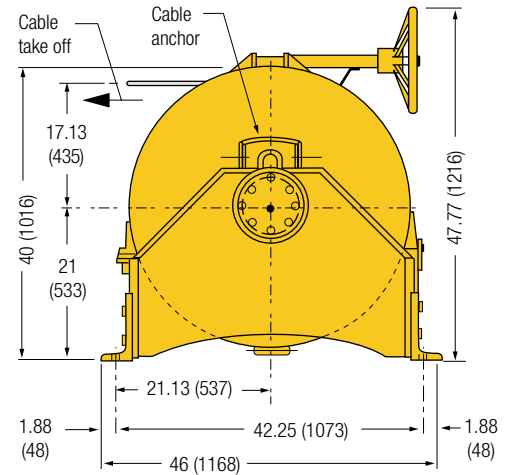
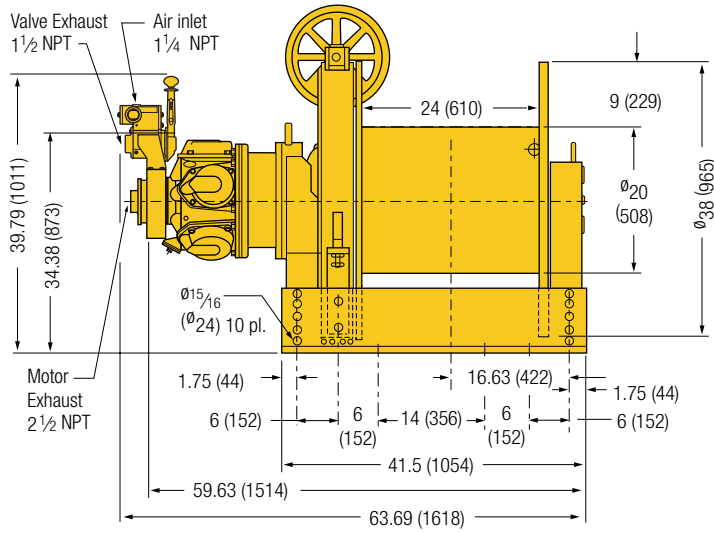

**FA10-24 – Popeye – with disc brake only in inches (mm)**

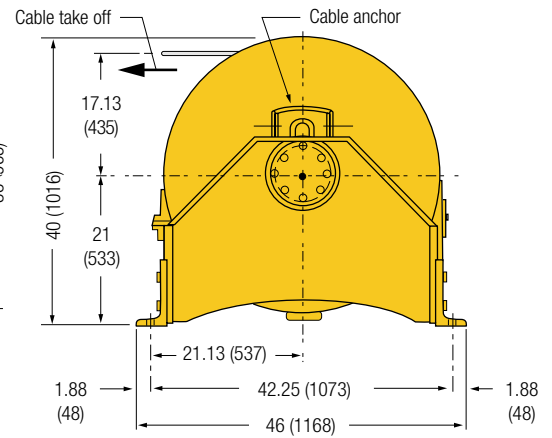
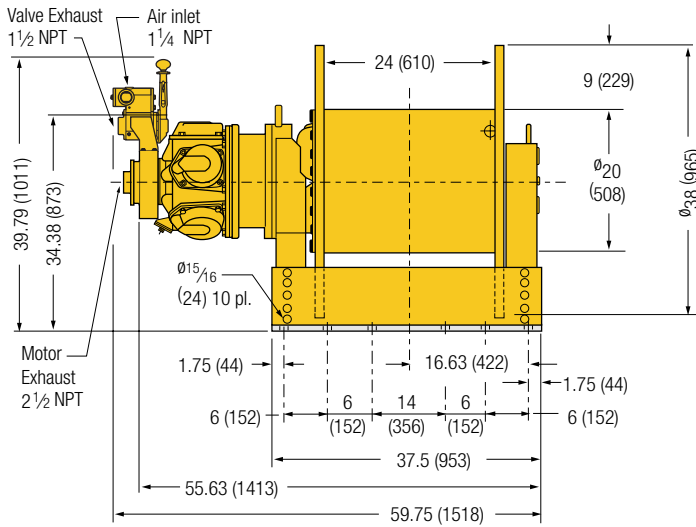

**FA10-40 – Popeye – with disc brake only in inches (mm)**

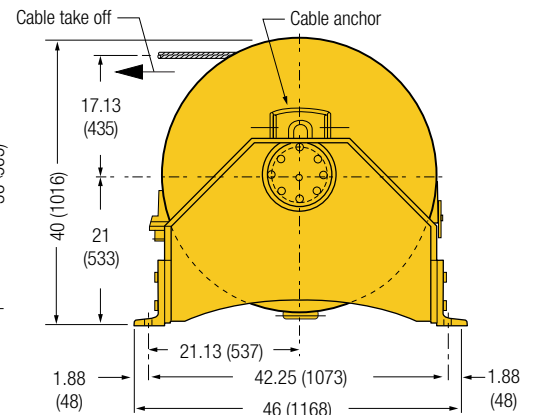
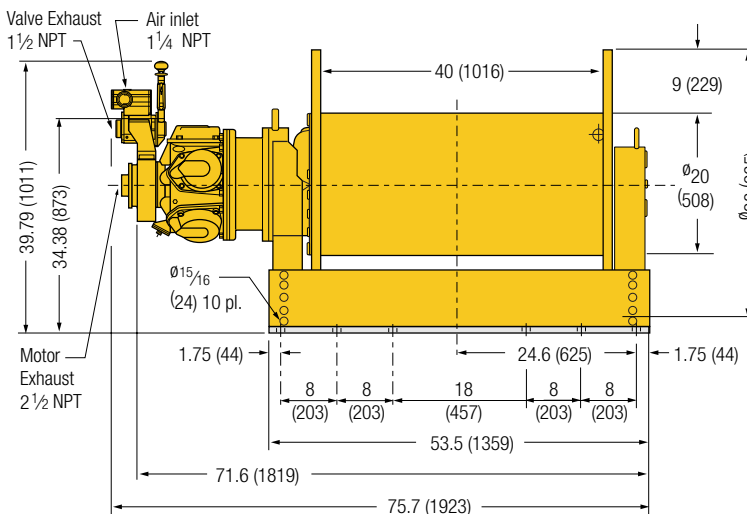

*DDimensions are subject to change. Contact factory for certified prints*

# Force 5™ Air Winch Series

## 4400 to 22000 lb (2000 to 10000 kg) capacity



### How to Order:

Specify complete model code as shown. To order options, use the option code in the option table and add as a suffix to the model code. To order a Force Five air winch with a non-standard drum length, refer to the available drum lengths provided in the drum length table below. Enter the desired drum length for each winch in the drum length section of the model code. To order accessories such as filters and lubricators, please enter these as separate accessory items by part number in the air winch accessories table below.

Example: **FA5-24MX1P**

Series	Capacity	Drum flange ht	Drum length	Drum brake	Disc brake	Control	Options (see Option Notes)
<b>FA</b>	<b>5</b>	<b>-</b>	<b>24</b>	<b>M</b>	<b>X</b>	<b>1</b>	<b>P</b>
2 = 4400 lbs (2000 kg) 2.5 = 5000 lbs (2273 kg) 5 = 11000 lbs (5000 kg) 5T = 8400 lbs (3818 kg) 7 = 15400 lbs (7000 kg) 7T = 12600 lbs (5727 kg) 10 = 22000 lbs (10000 kg)			24 = 24" (610 mm) between flanges. See drum length chart below.	K = Auto disc brake X = No auto disc brake A = Auto drum brake M = Manual drum brake X = No drum brake			7 = Drum grooving (specify rope size in sixteenths, e.g. 7 = 7/16") <sup>(2)</sup> C = Low temperature; please specify in text: -10° C or -20° C D = Drum divider flange and additional cable anchor <sup>(3)</sup> E = Construction cage G = Drum guard L = Drum locking pin M1 = Per DIN 50049/En10204 Para 2.2 "Typicals" <sup>(4)</sup> M2 = Per DIN 50049/En10204 Para 3.1b actual per product as purchased <sup>(4)</sup> M3 = Per DIN 50049/En10204 Para 3.1b actual per product as delivered in final condition <sup>(4)</sup> N = Type approval; please specify in text: DNV, ABS or Lloyds P = Marine 812 finish Q = Special paint; please specify S = Rotary limit switch (upper and lower) T = Tensioning manifold U = Underwound (available only with autodisc brake <b>XX</b> ) V = Press roller W = Witness; please specify X = Testing; please specify Z = Sandblast and carbozinc primer only -E = Compliance with the European Machinery Directive (includes emergency stop and overload protection). Insert at end of model code.
Force Five FA = Air powered FH = Hydraulic powered	- = Std flange height T = Tall flange (FA5T and FA7T only)		1 = Standard winch mounted throttle 2XX = Remote full flow lever throttle (max 20 ft/6 m) 3XX = Remote pilot pendent throttle (std = 6 ft/1.8 m; max 66 ft/20 m) <sup>(1)</sup> 4XX = Remote pilot lever throttle (max 66 ft/20 m) <sup>(1)</sup> 5XX = Remote electric over air throttle XX = Specify hose length or pendent cord in feet				
Notes:							
All Force 5 units come with standard six (6) strand wire rope anchor and winding directions for right hand overwind.							
<b>Option Notes:</b>							
(1) With remote pilot control option, line speeds will decrease.							
(2) Number designates drum grooving. Number equals wire rope size in sixteenths. The standard will be based on a right hand overwind rotation and spiral grooving for the recommended size of wire rope for the standard length of drum only. Grooving involving longer or shorter drums, or drums equipped with a divider flange will be an engineered item with longer lead time.							
(3) D = drum divider flange. The standard will be based on right hand over wind rotation. Two steel flanges are welded to the center of the drum. This provides the motor side of the drum (half) with a rope anchor. Anchor locations must be specified by the customer.							
(4) Documentation, witness testing and material traceability available; must be requested at time of order. Specify options or contact factory or your nearest Ingersoll-Rand distributor for information.							
<b>M1</b> Material traceability certificates according to EN 10204 (Ex DIN 50049) 2.2 on load bearing parts. This conformity document affirms (by the manufacturer) that parts are in compliance with the requirements of the order based on non-specific inspection and testing (i.e. results are typical material properties for these parts.)							
<b>M2</b> Material traceability certificates according to EN 10204 (Ex DIN 50049) 3.1b on load bearing parts. These documents affirm (by a department independent of the manufacturing department) that the actual parts used in the product are in compliance with the order based on specific inspection and testing (i.e. results are actual material properties for those parts.)							
<b>M3</b> Material traceability certificates according to EN 10204 (Ex DIN 50049) 3.1b on load bearing parts. These documents affirm (by a department independent of the manufacturing department) that the actual parts used in the product are in compliance with the order based on specific inspection and testing (i.e. results are actual material properties for those parts in a finished, as delivered condition.)							
Overload devices and drum revolution counters are available as engineered specials, with extended lead times.							

Model	Drum length available									
	Drum width in. (mm)									
	8 (203)	12 (305)	16 (406)	20 (508)	24 (610)	30 (762)	36 (915)	40 (1016)	42 (1067)	50 (1270)
FA2	yes	yes	yes	yes	Standard	yes	yes	special	special	special
FA2.5	yes	yes	yes	yes	Standard	yes	yes	special	special	special
FA5/FA5T	no	yes	yes	yes	Standard	yes	yes	special	special	special
FA7/FA7T	no	no	yes	yes	Standard	yes	yes	yes	yes	special
FA10	no	no	yes	yes	Standard	yes	yes	yes	yes	yes

Contact factory for lengths other than shown.

**For air line accessories — filters, regulators, lubricators, liquidators and strainers — please see the Accessories section.**

# Force 5™ “Guideline and Podline” Air Winches FA7TGL 3400 lb (1545 kg) FA7TPL 10200 lb (4636 kg)



As offshore oil drilling heads into deeper waters, IR Guideline and Podline winches are prepared to follow.

■ These specially configured versions of the “Popeye Junior” tall flange air winch feature:

- Top layer ratings insure “lift at any layer” capability
- 42 inch (1067 mm) drum flange height and length for maximum cable capacity. Other drum flange sizes are available.
- Corrosion resistant marine grade coating system: Sandblast to white metal finish and carbozinc primer with a Marine 812 finish.
- With T-handle, bullet nose, and grease points, the stainless steel locking dog is easy to operate, trouble free, and maintenance friendly.
- Winch mounted throttle for precise load control; remote control is optional.
- **Internal** automatic disc brake is protected from the elements.



■ Specific to the FA7TGL Guideline winch:

- A lower gear ratio and switching valve arrangement with pressure regulator preset for unmanned lowering of sub-sea equipment.
- Simply flipping a lever switches the winch from utility to guide line mode. In this mode, the winch can be overhauled at speeds up to 90 fpm (28 m/min).
- In guide line mode, a pressure regulator can be set to adjust the tension.

**Specifications at rated load: performance is based on 90 psi (6.3 bar) air inlet pressure with motor running**

Model no.	Lift Ratings			Average speed	Stall	Avg. air consump. at rated load	Inlet pipe size	Ship weight	Wire rope storage capacity		
	First	Mid	Top						5/8" (15 mm)	3/4" (19 mm)	7/8" (22 mm)
FA7TGL42 (Guideline)	7800 lbs 3545 kg	4850 lbs 2205 kg	3400 lbs 1545 kg	102 fpm 22 m/min	10000 lbs 4545 kg	750 scfm 21.3 m³/min	1 1/4" NPT 1 1/4" NPT	2981 lbs 1352 kg	10372 ft 3161 m	7480 ft 2280 m	5262 ft 1604 m
FA7TPL42 (Podline)	22800 lbs 10364 kg	14300 lbs 6500 kg	10200 lbs 4636 kg	45 fpm 13.8 m/min	36000 lbs 16364 kg	750 scfm 21.3 m³/min	1 1/4" NPT 1 1/4" NPT	2850 lb 1293 kg	not recommended	7480 ft 2280 m	5262 ft 1604 m

**Wire rope storage capacity \***

Model no.	1/2 in. (13 mm)	5/8 in. (15 mm)	3/4 in. (19 mm)	7/8 in. (22 mm)	1 in. (25 mm)	Wire rope breaking strngth	1/2 in. (13 mm)	5/8 in. (15 mm)	3/4 in. (19 mm)	7/8 in. (22 mm)	1 in. (25 mm)
	FA7TGL42	16005 ft 4880 m	10347 ft 3155 m	6865 ft 2093 m	5237 ft 1597 m		3937 ft 1200 m	26600 lbs 12091 kg	41200 lbs 18727 kg	58800 lbs 26727 kg	79600 lbs 36182 kg
FA7TPL42	not recommended		6865 ft 2093 m	5237 ft 1597 m	3937 ft 1200 m	Wt per ft Wt per m	0.46 lbs 0.69 kg	0.72 lbs 1.07 kg	1.04 lbs 1.55 kg	1.42 lbs 2.12 kg	1.85 lbs 2.76 kg

\* Capacities represent tightly wound wire rope. Recommended working capacity is 80% of values shown.

**Dimensions: inches (mm)**

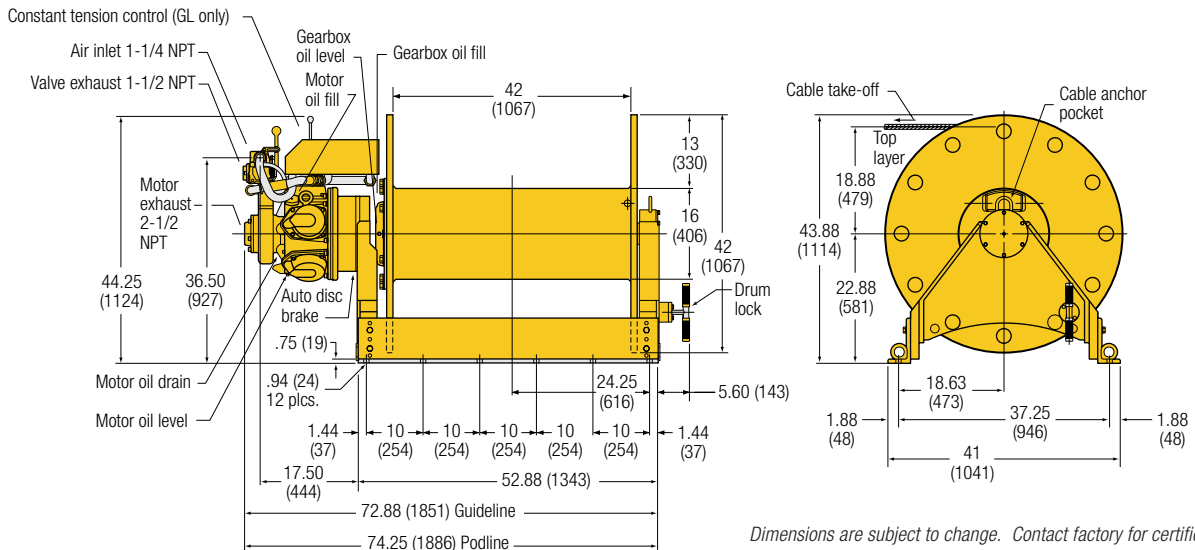

Dimensions are subject to change. Contact factory for certified prints

# Accu-Spool™ Level Wind

3400 to 22000 lbs (1545 to 10000 kg) capacity



**Setting the standards in level wind technology: a totally self-compensating level wind for precise and continuous spooling of wire rope or cable. Never needs adjustment.**

Available as optional equipment for IR manufactured winches or as a retrofit for winches and cable reels of other manufacturers. No attachment to existing winch is required. Retrofit unit is a free-standing design, which can fit any winch or cable reel, etc.

**How It Works:**

The IR Accu-Spool level wind is universally adaptable to the entire Force 5 air winch line and to winches produced by other manufacturers. When winch fleet angles exceed 2 degrees, wire rope spooling becomes difficult. The IR Accu-Spool level wind will spool the rope uniformly and repeatedly on the drum in applications where fleet angles vary from 0 to 26 degrees.

**Standard features:**

- Rack and pinion drive resists wear from corrosive elements when compared with diamond screw type level winds
- No gear interlocks or drive chains to wear, corrode or get out of adjustment
- Durable radial piston air motor provides independent power source
- No drive attachment to the winch is required
- Bronze worm drive and steel worm gear
- Steel guide bar and guide rollers
- Heavy duty rack and pinion drive allows for precise, continuous spooling and reduced wire rope wear
- Totally self-compensating and adjusting. The design overcomes the timing problems inherent in diamond screw types of level winds



Accu-Spool with FA10-40

- Compensates for fleet angles up to 26°
- Allows wire rope take off in almost any direction
- Emergency manual override on control systems is standard
- Line tension of approximately 5% of actual load is required to activate the Accu-Spool

**The main components are:**

1. Guide bar: alloy steel tube with rack and pinion drive
2. Guide system: steel guide rollers, worm gear drive and radial piston air motor

The Accu-Spool's sensor rollers keep the level wind axis and drum perpendicular to the wire rope on the drum. When the winch line pull pressure is applied to the sensor roller, the roller will activate linkage that opens the motor valve, driving the level wind in the appropriate direction to spool the wire rope evenly on the drum.

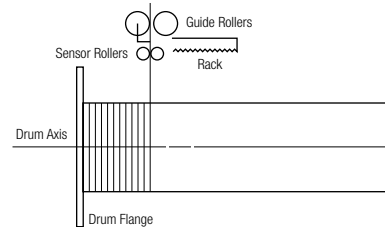

**Specifications: 90 psi (6.3 bar)<sup>(1)</sup>**

Force-5 model	Winch capacity (tons)	Accu-Spool model air	Standard drum length in.	Standard drum length mm	Avg. air consumption required	
					cfm	m <sup>3</sup> /min
FA2	2	ASA2	24	610	55	1.6
FA2B <sup>(2)</sup>	2	ASA2	24	610	55	1.6
FA2.5	2.5	ASA2	24	610	55	1.6
FA2.5A <sup>(2)</sup>	2.5	ASA2	24	610	55	1.6
FA5(T)	5	ASA5	24	610	55	1.6
FA5A <sup>(2)</sup>	5	ASA5	24	610	55	1.6
FA7(T, PL, GL)	7	ASA7	24	610	55	1.6
FA10	10	ASA10	24	610	55	1.6

(1) Performance is based on 90 psi (6.3 bar) air inlet pressure with motor running. Level wind will increase overall length of the winch by approx. 4 inches (102 mm).

(2) Not available on units with automatic disc brake.

**Maximum fleet angle for Accu-Spool models is 26°. See "The importance of fleet angle" in the Tech Tips section.**

**Determining rope take off:** If required, the Accu-Spool level wind can be provided to work through a designated range of rope take off angles. Specify your needs accordingly.

**How to special order:**

**Please provide the following information:**

1. Total line pull
2. Wire rope or cable size
3. Fleet angle
4. Rope take off direction (e.g. horizontal, vertical or other angle)
5. Potential clearance problems, maximum envelope size
6. Type and size of foundation (platform, concrete base, etc)
7. Power source (air, electric or hydraulic)
8. Drum width
9. Drum diameter

**Components for OEM purchase (complete less mounting frame):**

1. Support tube with rack
2. Drive package: includes motor, valve, and gearing (assembled)

# Force 5™ “Offshore” Man Rider™ Series

330 to 6870 lb (150 to 3117 kg) capacity



**Known worldwide as the standard for meeting the toughest personnel lifting requirements in the offshore industry.**

Dual rated for personnel and utility lifting applications, these winches have Type Approval or Independent Review certificates issued by the classification societies of ABS, DNV or LRS. Meet NPD, NMD and UK HSE regulations for personnel lifting operations. Oil field tough to weather the harsh environments in marine applications.

### Definitions

■ **Third party:** An independent certifying agency that offers formalized review and approval programs for Man Rider winches accepted for suitability to lift personnel. Recognized third party agencies are:

- American Bureau of Shipping (ABS)
- Det Norske Veritas (DNV)
- Lloyd’s Register of Shipping (LRS)

■ **Type Approval:** A comprehensive design review by an independent third party which examines the intended service and application, winch ratings, design calculations of load bearing components, product specifications and service restrictions or limitations. A plant survey is also conducted to verify that quality control procedures and features are adequate and consistent. Upon successful completion, a **Type Approval** certificate is issued.

■ **Third Party Certification:** A review process of quality by an independent third party requested by the customer. Includes:

1. Type Approval certificate (design)
2. Third party survey during manufacturing (quality)
3. Third party witness of performance testing (quality)
4. Issuance of certificates as required by regulatory agency acknowledging compliance.

### Standard features:

- Enclosed automatic oil bath “wet” disc brake is fully sealed against salt spray, dirt or moisture and provides trouble-free operation over thousands of lifting cycles.
- Manual drum mounted band brake for additional braking by operator
- Internal gearbox / disc brake combination for superior load control
- Corrosion resistant drum guard supports the weight of a 200 lb/ 91 kg person.



FA150KGMR

- Dual rated 8:1 design factor for manrider rating; 5:1 design factor for utility rating
- Compact, frame and fabricated alloy steel drum fit into tight spaces
- Standard operating temperature range is 0°C through 60°C; optional design temperature of -10°C or -20°C
- Minimum 18:1 drum diameter to wire rope diameter ratio reduces wire rope wear.
- Data book and “Type Approval” certificates available upon request.
- Marine 812 paint system on FA150KGMR models.

### Options and accessories:

- Automatic band brakes
- Variable drum lengths
- Grooved drums
- Drum divider flange
- Upper and lower limit switches
- Corrosion resistant marine grade coating system: sandblast to white metal finish and carbozinc primer with a Marine 812 finish
- Remote controls
- Air prep package: filter, lubricator, strainer, liquidator and regulator
- Muffler
- Hydraulic models
- Electric-Over-Air remote control pendant for unlimited pendant length
- Third party certifications for low temperature applications

### Specifications: performance is based on 90 psi (6.3 bar) air inlet pressure with motor running

Model no.	Force 5 MR ratings at top layer				Personnel rating		Maximum		Average air		Pipe		Hose		Shipping	
	Personnel (1)		Utility (2)		avg line speed	stall pull	lbs	kg	scfm	m <sup>3</sup> /min	in.	mm	in.	mm	lbs	kg
	lbs	kg	lbs	kg	fpm	m/min										
FA150KG12MR-1-E	330	150	n/a	n/a	87	26	(3)	(3)	50	1.4	0.5	13	3/4	19	750	340
FA2MR24MK1G	3180	1445	4400	2000	75	23	9000	4090	335	9.5	1 1/4	32	1 1/4	32	906	411
FA2.5MR24MK1G	3180	1445	5000	2273	159	48	10000	4545	700	19.9	1 1/4	32	1 1/2	38	1178	534
FA5MR24MK1G	6870	3123	11000	5000	69	21	24000	10909	700	19.9	1 1/4	32	1 1/2	38	2020	916
Force 5 Third Generation Man Rider Series ratings at mid layer (4)																
FA2BMR-MK1G	2500	1136	4000	1818	168	51	6800	3084	380	10.8	1 1/4	32	1 1/2	38	786	357
FA2.5AMR-MK1G	3125	1420	5000	2273	173	53	10400	4727	560	15.9	1 1/4	32	1 1/2	38	905	411
FA5AMR-MK1G	6250	2841	10000	4545	102	31	17000	7727	600	17.0	1 1/4	32	1 1/2	38	1842	837

(1) “-E” models for European Union allow one lift capacity rating only; i.e., only personnel lift rating is allowed for both personnel and utility applications.

(2) Utility rating only for those countries that allow dual ratings, e.g. USA.

(3) Per NPD regulations

(4) Third Generation Man Riders are not available in CE format.

**Rope storage for personnel lifting<sup>(1)</sup>**

Model number	Drum length		10mm		Rope diameter			
	in.	mm	ft	m	1/2"	13mm	3/4"	19mm
FA150KGMR	8	203	474	144	–	–	–	–
	12	305	723	220	–	–	–	–
	16	406	972	296	–	–	–	–
	24	610	1470	448	–	–	–	–
FA2MR and FA2.5MR	8	203	–	–	321	97	–	–
	12	305	–	–	492	150	–	–
	16	406	–	–	663	202	–	–
	24	610	–	–	1006	306	–	–

Model number	Drum length		10mm		Rope diameter			
	in.	mm	ft	m	1/2"	13mm	3/4"	19mm
FA5MR	8	203	–	–	–	–	235	72
	12	305	–	–	–	–	365	111
	16	406	–	–	–	–	495	151
	24	610	–	–	–	–	755	230
FA2BMR and FA2.5AMR	S 7	178	–	–	198	60	–	–
	M 13.5	343	–	–	396	120	–	–
	L 20	508	–	–	595	181	–	–
FA5AMR	R 24	610	–	–	717	218	–	–
	S 12	305	–	–	–	–	321	98
	L 24	610	–	–	–	–	663	202

(1) Based on UK HSE standards requiring top layer to be 2 1/2 times the wire rope diameter below drum flange.

**Rope speed at mid drum at 90 psi**

Winch series	at 330 lbs (150 kg)				at personnel rating				at utility rating			
	Up		Down		Up		Down		Up		Down	
	fpm	m/min	fpm	m/min	fpm	m/min	fpm	m/min	fpm	m/min	fpm	m/min
FA150KGMR	87	26	100	31	87	26	100	31	n/a	n/a	n/a	n/a
FA2MR	121	37	60	18	72	22	125	38	53	16	140	43
FA2.5MR	235	71	125	38	160	49	155	47	113	34	190	58
FA5MR	94	29	60	18	69	21	55	17	54	16	70	21
FA2BMR	253	77	–	–	160	49	–	–	102	31	–	–
FA2.5AMR	257	78	–	–	173	53	–	–	117	36	–	–
FA5AMR	177	54	–	–	102	31	–	–	50	15	–	–

**Dimensions**

FA150KGMR with disc and manual brake in inches (mm)

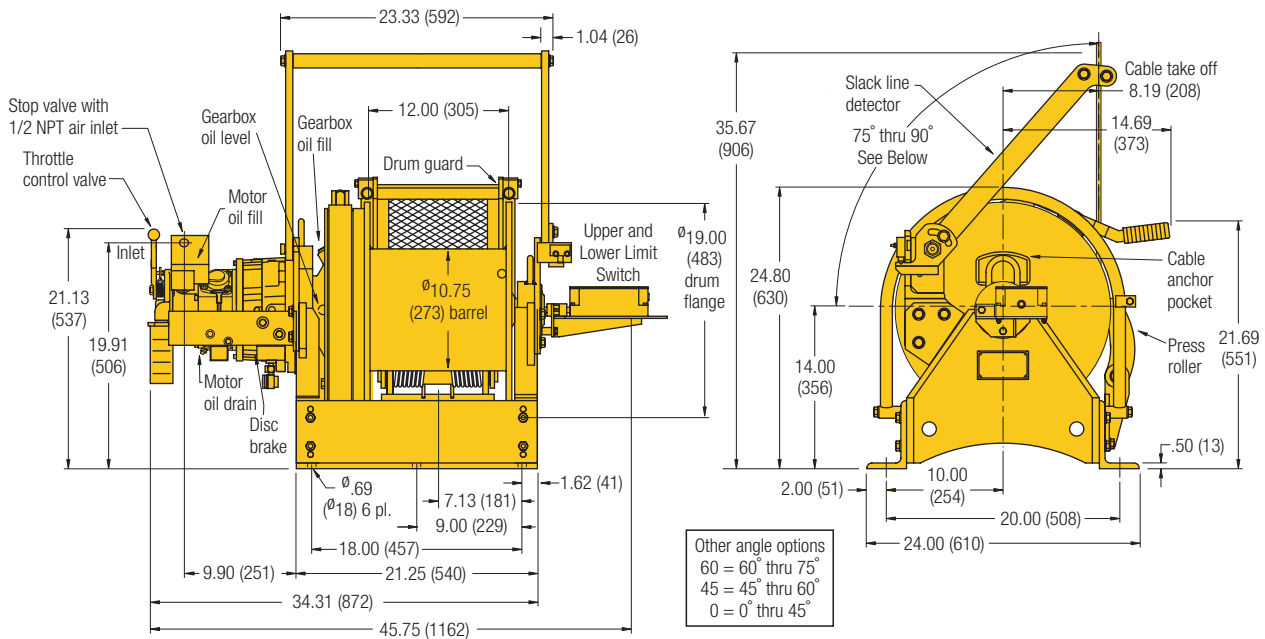

Dimensions are subject to change. Contact factory for certified prints



# Force 5™ "Offshore" Man Rider™ Series

## 330 to 6870 lb (150 to 3117 kg) capacity



### Dimensions

FA2MR24MK1G with disc and manual brake in inches (mm)

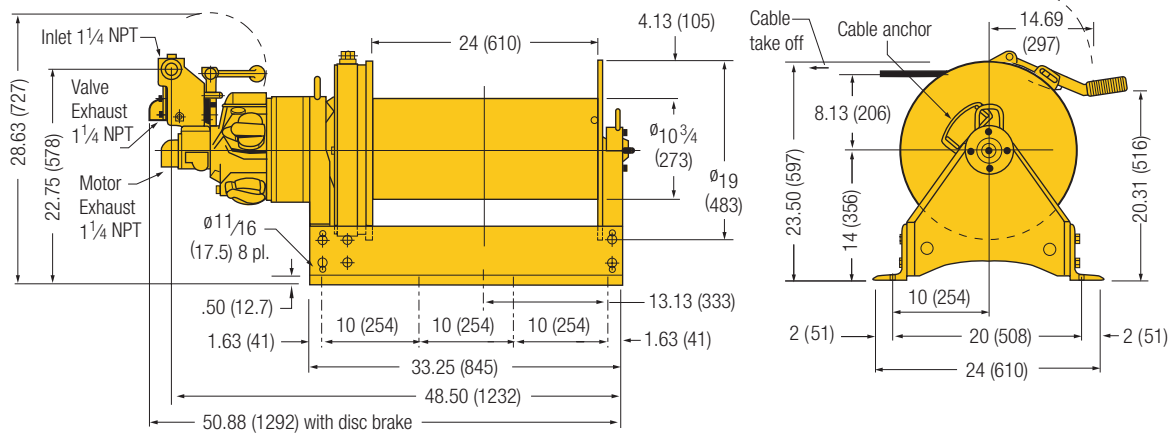

FA2.5MR24MK1G with disc and manual brake in inches (mm)

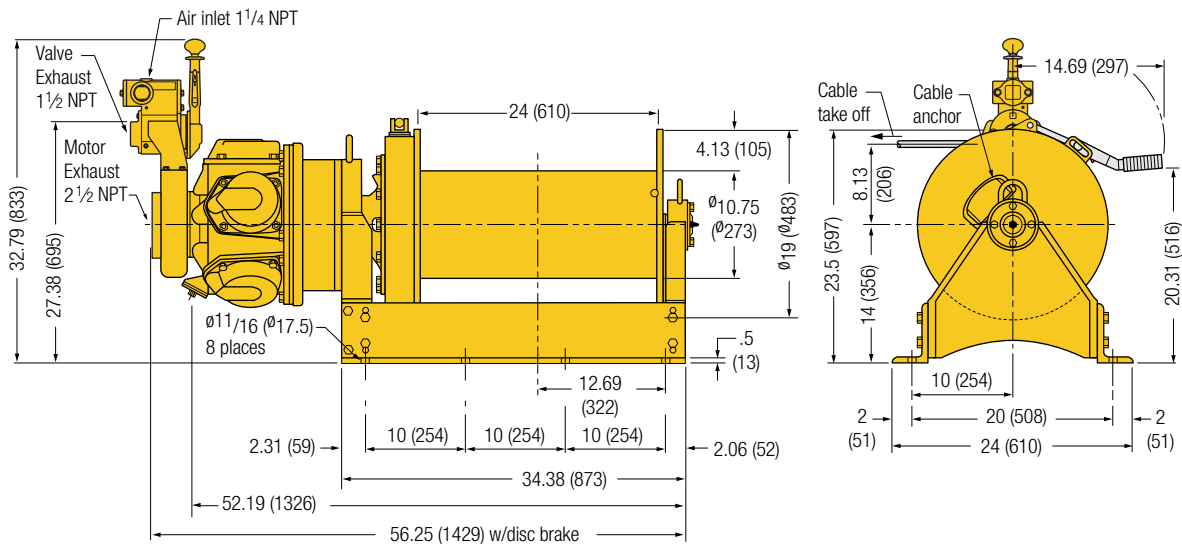

FA5MR24MK1G with disc and manual brake in inches (mm)

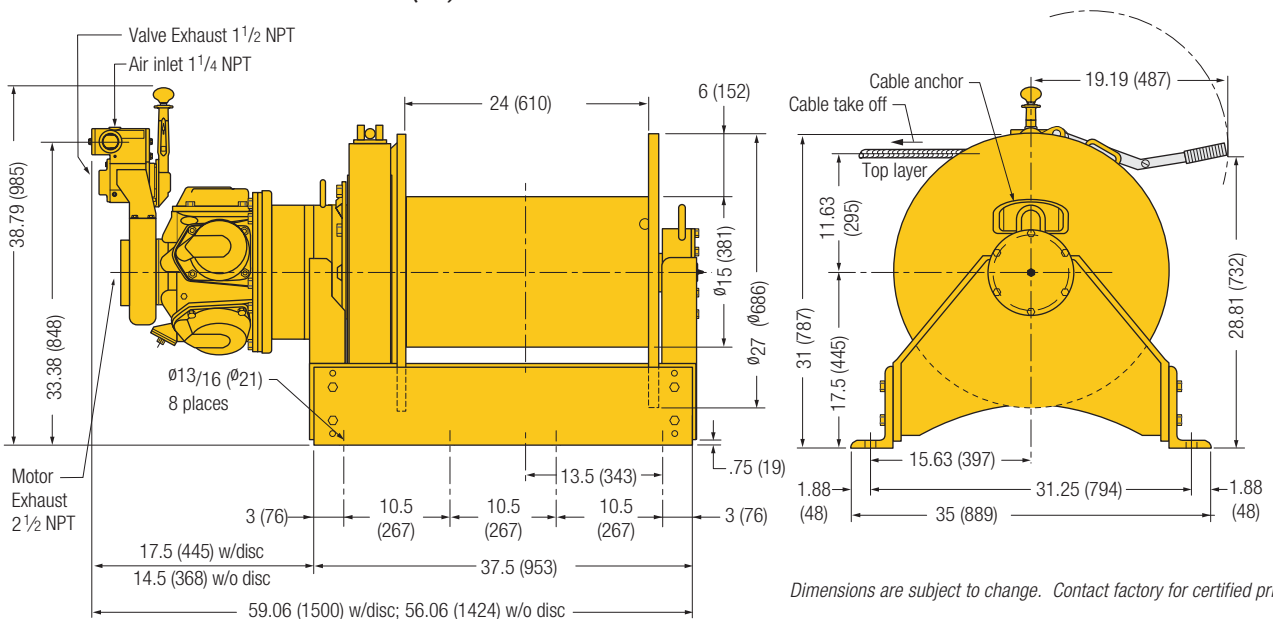

Dimensions are subject to change. Contact factory for certified prints

# Force 5™ "Offshore" Man Rider™ Series

330 to 6870 lb (150 to 3117 kg) capacity



## Dimensions

Model no.	A		B		C		D	
	in.	mm	in.	mm	in.	mm	in.	mm
FA2BMR-SMK1G	7.0	178	37.4	950	12.3	312	7.5	191
FA2BMR-MMK1G	13.5	343	43.9	1115	18.8	478	10.81	274
FA2BMR-LMK1G	20.0	508	50.4	1280	25.3	643	14.0	356
FA2BMR-RMK1G	24.0	610	54.4	1382	29.3	744	16.0	406

## Dimensions

Model no.	A		B		C		D	
	in.	mm	in.	mm	in.	mm	in.	mm
FA2.5AMR-SMK1G	7.0	178	41.19	1046	12.31	313	7.50	191
FA2.5AMR-MMK1G	13.5	343	47.69	1211	18.81	478	10.81	274
FA2.5AMR-LMK1G	20.0	508	54.19	1376	25.31	643	14.00	356
FA2.5AMR-RMK1G	24.0	610	58.19	1478	29.31	744	16.00	406
FA5AMR-SMK1G	12.0	305	46.50	1181	17.89	454	10.50	266
FA5AMR-LMK1G	24.0	610	58.13	1486	29.89	759	16.50	419

### FA2BMR in inches (mm)

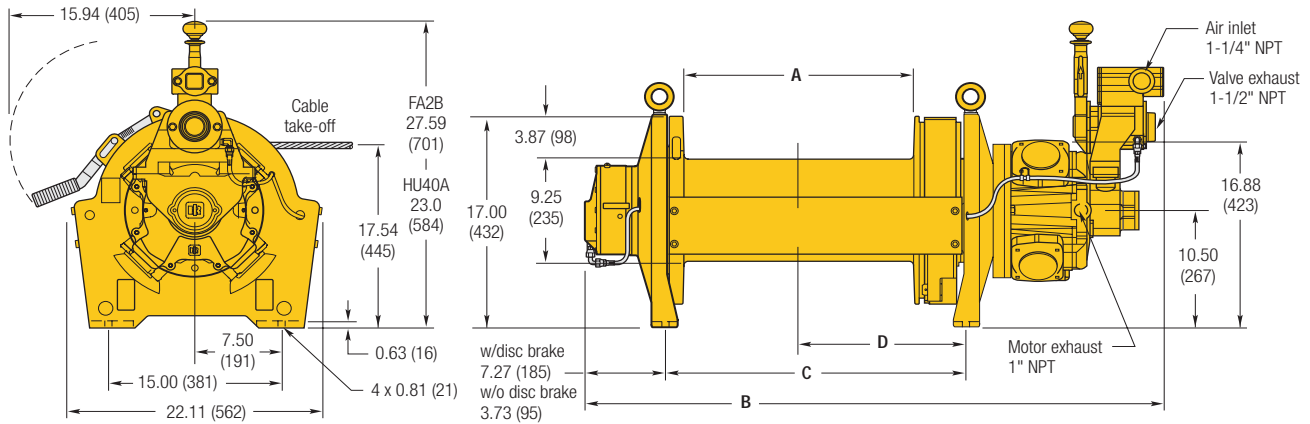

### FA2.5AMR in inches (mm)

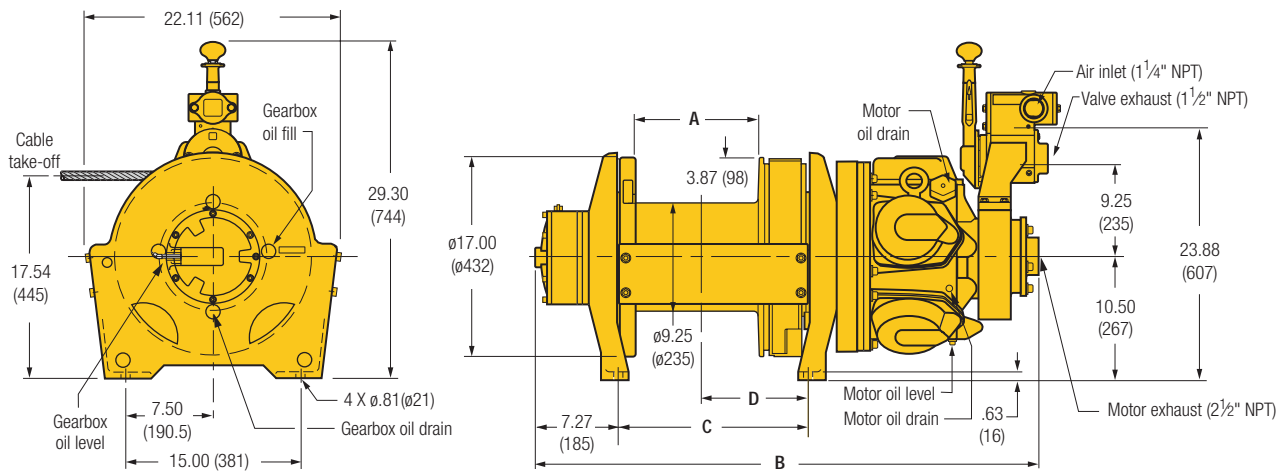

### FA5AMR in inches (mm)

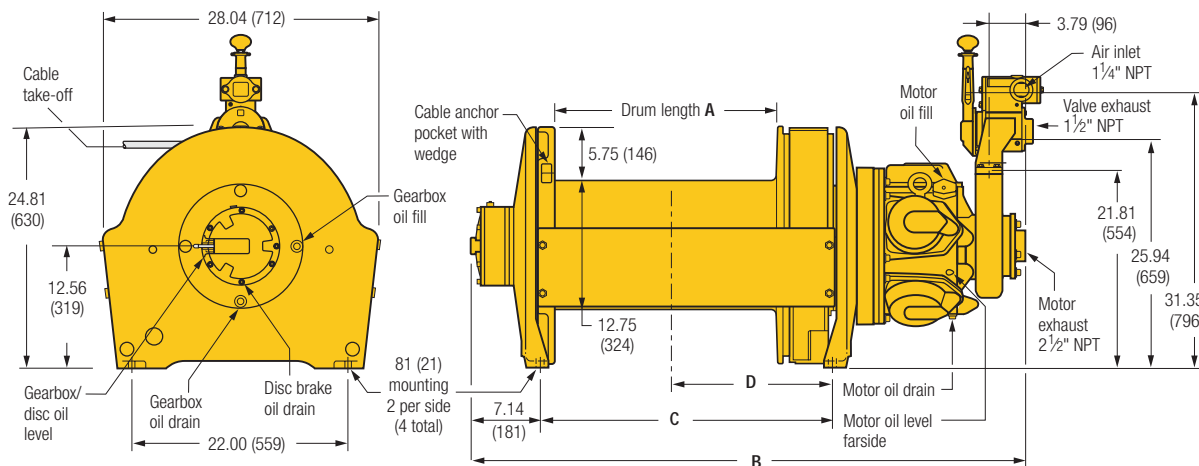

Dimensions are subject to change. Contact factory for certified prints

# Force 5™ “Offshore” Man Rider™ Series

## 330 to 6870 lb (150 to 3117 kg) capacity



### How To Order:

Specify complete model code as shown. To order options, use the option code in the option table and add as a suffix to the model code. To order a Force Five air winch with a non-standard drum length, refer to the available drum lengths provided in the drum length table below. Enter the desired drum length for each winch in the drum length section of the model code. To order accessories such as filters and lubricators, enter these as separate accessory items by the part number in the air winch accessories table. **Example: FA2.5MR24MK1GP**

Series	Personnel cap.	Man Rider cap.	Drum length	Drum brake	Disc brake	Control brake	Options (see notes below)
<b>FA</b>	<b>2.5</b>	<b>MR</b>	<b>24</b>	<b>M</b>	<b>K</b>	<b>1</b>	<b>GP</b>
150KG = 330 lbs (150 kg) (Contact technical sales for special model driver)		<b>MR</b> = Man Rider	<b>24</b> = 24" (610 mm) between flanges. See drum length charts below.	<b>M</b> = Auto drum brake <b>M</b> = Manual drum brake (std)	<b>K</b> = Auto disc (std)		<b>7</b> = Drum grooving (specify rope size in sixteenths, e.g. 7 = 7/16") <sup>(2)</sup> <b>C</b> = Low temperature; please specify in text: -10° C or -20° C <b>D</b> = Drum divider flange and additional cable anchor <sup>(3)</sup> <b>G</b> = Drum guard <b>L</b> = Drum locking pin <sup>(5)</sup> <b>M1</b> = Per DIN 50049/En10204 Para 2.2 "Typicals" <sup>(4)</sup> <b>M2</b> = Per DIN 50049/En10204 Para 3.1b actual per product as purchased <sup>(4)</sup> <b>M3</b> = Per DIN 50049/En10204 Para 3.1b actual per product as delivered in final condition <sup>(4)</sup> <b>N</b> = Type approval; please specify in text: DNV, ABS or Lloyds <b>P</b> = Corrosion resistant marine grade coating system: sandblast to white metal finish and carbozinc primer with a Marine 812 finish <b>Q</b> = Special paint; please specify <b>S</b> = Limit switch (upper and lower) <sup>(5)</sup> <b>U</b> = Underwound (available only with autodisc brake <b>XX</b> ) <b>V</b> = Press roller <b>W</b> = Witness; please specify <b>X</b> = Special testing; please specify <b>Z</b> = Sandblast and carbozinc primer only <b>-E</b> = Compliance with European Machinery Directive (insert at end of model code) <sup>(5)</sup>
2B = 2500 lbs (1136 kg)	2.5A = 3125 lbs (1420 kg)		<b>1</b> = Standard winch mounted throttle				
2 = 3180 lbs (1445 kg)	<b>2.5</b> = 3180 lbs (1445 kg)		<b>2XX</b> = Remote full flow lever throttle (max 20 ft/6 m)				
5A = 6250 lbs (2841 kg)	5 = 6870 lbs (3111 kg)		<b>3XX</b> = Remote pilot pendent throttle (std = 6 ft/1.8 m; max 66 ft/20 m) <sup>(1)</sup>				
			<b>4XX</b> = Remote pilot lever throttle (std = 6 ft/1.8 m; max 66 ft/20 m) <sup>(1)</sup>				
			<b>5XX</b> = Remote electric over air throttle				
			<b>XX</b> = Specify hose length or pendent cord in feet				

Force Five  
**FA** = Air powered  
**FH** = Hydraulic powered

Notes:  
All Force 5 units come with standard six (6) strand wire rope anchor and winding directions for right hand overwind.

**Option Notes:**

- (1) With remote pilot control option, line speeds will decrease.
- (2) Number designates drum grooving. Number equals wire rope size in sixteenths. The standard will be based on a right hand overwind rotation and spiral grooving for the recommended size of wire rope for the standard length of drum only. Grooving involving longer or shorter drums, or drums equipped with a divider flange will be an engineered item with longer lead time.
- (3) **D** = drum divider flange. The standard will be based on right hand over wind rotation. Two steel flanges are welded to the center of the drum. This provides the motor side of the drum (half) with a rope anchor. Anchor locations must be specified by the customer.
- (4) Documentation, witness testing and material traceability available; must be requested at time of order. Specify options or contact factory or your nearest IR distributor for information.
  - M1** Material traceability certificates according to EN 10204 (Ex DIN 50049) 2.2 on load bearing parts. This conformity document affirms (by the manufacturer) that parts are in compliance with the requirements of the order based on non-specific inspection and testing (i.e. results are typical material properties for these parts.)
  - M2** Material traceability certificates according to EN 10204 (Ex DIN 50049) 3.1b on load bearing parts. These documents affirm (by a department independent of the manufacturing department) that the actual parts used in the product are in compliance with the order based on specific inspection and testing (i.e. results are actual material properties for those parts.)
  - M3** Material traceability certificates according to EN 10204 (Ex DIN 50049) 3.1b on load bearing parts. These documents affirm (by a department independent of the manufacturing department) that the actual parts used in the product are in compliance with the order based on specific inspection and testing (i.e. results are actual material properties for those parts in a finished, as delivered condition.)
- (5) Not available on Third Generation Series

Drum lengths		
FA2B & FA2.5A	in.	mm
S	7	178
M	13 1/2	343
L	20	508
R	24	610
FA5A		
S	12	305
L	24	610

Drum lengths available in. (mm)						
Model	8 (203)	12 (305)	16 (406)	24 (610)	30 (762)	36 (914)
FA150KG	yes*	Std	yes*	yes	yes*	yes*
FA2	yes	yes	yes	Std	yes*	yes*
FA2.5	yes	yes	yes	Std	yes	yes
FA5	no	yes	yes	Std	yes	yes

Contact factory for lengths other than shown.  
\* Special order

- Special optional requirements for offshore compliance are available (see codes above where applicable):
- Material traceability
  - Charpy testing
  - Certificate of compliance
  - Third party witness
  - Customer witness
  - Special documentation
  - Regulatory agency certification
  - Low temperature materials

Man Rider winches have been designed and built to meet the requirements of the Offshore Oil Industry, particularly those specifications of the Norwegian Maritime Directorate, the Norwegian Petroleum Directorate and the UK HSE. They are Type Approved by Lloyds Register of Shipping, Det Norske Veritas (DNV) and the American Bureau of Shipping (ABS). There is no standard covering the use of these Man Riders in other than the offshore environment. It is, therefore, the user's responsibility to determine the suitability of this product for any particular use and to check for compliance with applicable regulations.

# Third Generation "Offshore" Gulf Man Rider™ 2500 lb (1136 kg) capacity



Based on the design of our Force 5 Man Riders and the popular FA2B modular winch, IR is pleased to introduce the FA2B-GMR, the Gulf Man Rider™

When operating in the Gulf of Mexico, the guidelines of certifying bodies may not apply, but common sense and safe operating practices do. The **Gulf Man Rider™** is IR's solution. It meets all the offshore and rating criteria we apply to all Man Riders. We also provide a third party (DNV) witness certificate with performance specifications; this is your assurance of quality and reliability.

### Standard features:

- Dual brakes: auto disc and manual band type. Both are capable of holding 200% of the rated load.
- 8:1 design factor: The recommended wire rope size to maintain this factor is ½ in. (13 mm) extra improved plow steel (EIPS) with independent wire rope core (IWRC).
- Stainless steel and corrosion resistant fasteners
- Standard design temperature of 0° C
- Self closing, dual action throttle handle is offshore tough
- Wedge type rope anchor for easy, "tool-less" installation holds up to 80% of rope breaking strength



FA2B-GMR-LMK1G

- Available in short **S**, medium **M**, long **L** and extra long **R** drum lengths
- Dual rated 8:1 design factor for manrider rating; 5:1 design factor for utility rating

### Options:

- Unlike our other Man Riders, drum guards are optional on Gulf Man Riders. Add suffix **G** for this highly recommended option.
- There is no **-E** European version

### Specifications and performance at 90 psi

Model no.	Ratings at mid layer		Optional design temp	Maximum stall pull		Average air consumption		Pipe inlet	Hose size	Shipping weight	
	Utility lbs	Personnel kg		lbs	kg	scfm	m³/min			in.	mm
FA2B-GMR	4000	1818	2500 1136	-10° or -20°c	6800 3084	380 10.8	1 ¼ 32	1 ½ 38	786 357		

### Rope speed at mid drum at 90 psi

Winch series	at 330 lbs (150 kg)				at personnel rating				at utility rating			
	Up		Down		Up		Down		Up		Down	
	fpm	m/min	fpm	m/min	fpm	m/min	fpm	m/min	fpm	m/min	fpm	m/min
FA2B-GMR	274	90	150	46	164	54	141	43	96	31	260	79

### Dimensions: FA2B-GMR

Model no.	A		B		C		D	
	in.	mm	in.	mm	in.	mm	in.	mm
FA2B-GMR-SMK1	7.0	178	34.3	871	12.3	312	4.8	121
FA2B-GMR-MMK1	13.5	343	40.8	1036	18.8	478	8.0	204
FA2B-GMR-LMK1	20.0	508	47.3	1201	25.3	643	11.3	286
FA2B-GMR-RMK1	24.0	610	51.3	1303	29.3	744	13.3	337

### FA2B-GMR in inches (mm)

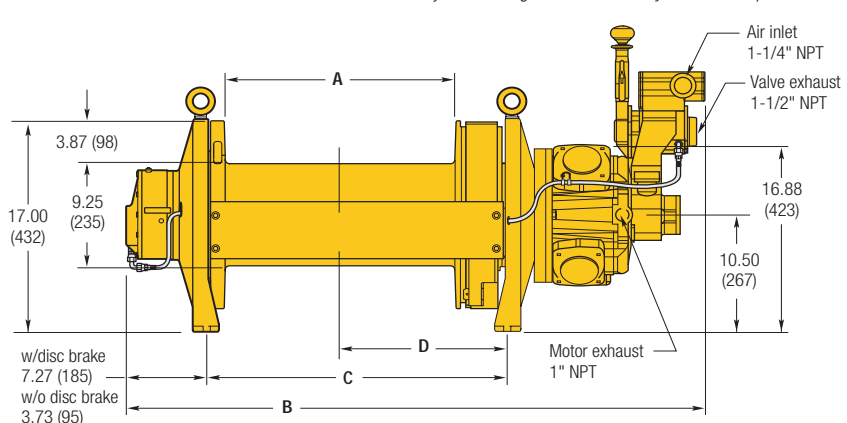
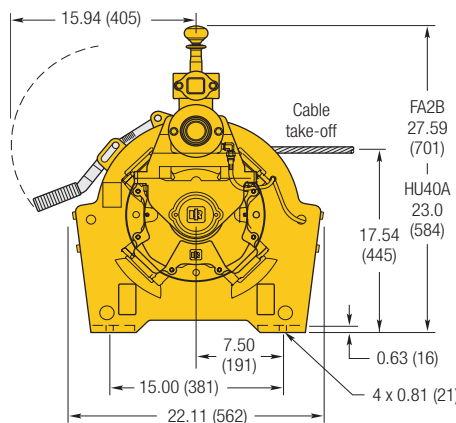

Dimensions are subject to change. Contact factory for certified prints

### Drum storage<sup>(1)</sup>

Model no.	Drum code	Drum length		Rope dia. ½ (13)	
		in.	mm	ft	m
FA2B	S	7	178	300	91
	M	13.5	343	600	183
	L	20	508	900	274
	R	24	610	1085	331

(1) Leaving ½ inch (13 mm) flange clearance

### How to Order:

Specify FA2B-GMR-"X"MK1 and substitute S, M, L or R for the "X" for drum length. Add suffix G for drum guard option. See Third Generation section for additional information and options.

Example: **FA2B-GMR-LMK1G**

## Liftstar "Offshore" Man Rider™ Series 330 to 2200 lb (150 to 1000 kg) capacity



**Designed to the toughest Type Approval standards issued by the classification societies and meets NPD, NMD and UK HSE regulations for personnel lifting operations on offshore installations. The "Liftstar Man Rider" is a dedicated personnel lifting winch offered with Det Norske Veritas (DNV) Type Approval and full traceability.**

### ■ Liftstar 150 kg / Pneumatic:

The LS150RLP...-E models have been specifically designed for personnel lifting applications in which a safety harness or a boatswain's chair is used on fixed installations. They have passed the DNV (Det Norske Veritas) EC testing for these applications, i.e., both the winches and their technical files are in compliance with the requirements of the EC Machinery Directives.

The LS150RLP-DP5M-F model is in compliance with section 28 of the NPD (Norwegian Petroleum Directorate) regulation for manriding applications using a safety harness in petroleum drilling and well activities on mobile/floating installations.

### ■ Pneumatic and hydraulic models— 500 and 1000 kg capacity:

For use with assemblies using a platform, basket, carrier, etc... These models should be considered "part machines," as they are intended for incorporation into an assembly consisting of a platform, a suspension system, etc... Therefore, they are delivered without the CE mark, but with a Declaration of Incorporation. However, since they are equipped with selected safety options, when the user applies for EC compliance of the entire personnel lifting system, the winch "part" will meet the EC requirements.

### ■ Standard features:

#### All models:

- Two independent automatic brakes: an internal oil bath multidisc brake and an external drum band brake. Each can hold 180% of SWL.
- Flange mounted overload protection device
- Direct lever control with fine inching characteristics and automatic return to neutral when brakes are applied
- Main air emergency stop (for air models only)
- High efficiency planetary gearing is inside drum for better protection and minimum overall dimensions
- Hot dip, galvanized drum guard
- Sandblasting, carbozinc primer and offshore paint 290µ
- 3.1b material traceability certificates according to DIN 50049 (EN 10204) for load bearing parts available upon request at time of order
- Stainless steel external brake cylinder and control rods
- All external fasteners larger than 10 mm are stainless steel or electro-zinc plated
- Delivered with skid frame for easy installation



LS1000RLP Man Rider

### The LS150RLP...-E and the LS150RLP-DP5M-F models:

- Upper and lower limit switches
- Slack wire detector
- Assisting spooling device – for better rope winding at no load
- Pre-equipped emergency lowering device (pressurized nitrogen bottle not supplied)

### Additional standard features:

- The LS150RLP...-E includes a CE manual for installation and operation
- The LS150RLP-DP5M-F includes a rope payout system and filter-regulator-lubricator assembly

### ■ Options

#### All models:

- Witness test(s) by a third party (DNV, Lloyd's, ABS, etc)

#### 500 and 1000 kg capacity models

- Upper and lower limit switches
- Assisting spooling device
- Pre-equipped emergency lowering device for air model only (pressurized nitrogen bottle not supplied)
- Slack wire detector (electric on hydraulic models)

#### All models except LS150RLP-DP5M-F:

- PHS remote control piloted pendant allows infinitely variable up and down speeds with complete operator control. Fitted with an emergency stop device which acts directly on the main air flow

# Liftstar "Offshore" Man Rider™ Series

## 330 to 2200 lb (150 to 1000 kg) capacity



### Specifications – pneumatic models at 90 psi (6.3 bar)

Model no.	Rated working load		Hoisting speed <sup>(1)</sup>		Rec'd rope dia		Free air consumption		Motor power		Weight w/o rope	
	lbs	kg	fpm	m/min	in.	mm	scfm	m <sup>3</sup> /min	hp	kw	lbs	kg
LS150RLP-E	330	150	0 to 115	0 to 35	3/8	10	0 to 78	0 to 2.2	2	1.5	250	114
LS500RLP	1100	500	0 to 79	0 to 24	1/2	13	0 to 123	0 to 3.5	3	2.2	300	136
LS1000RLP	2200	1000	0 to 79	0 to 24	1/2	13	0 to 123	0 to 3.5	6	4.5	300	136

### Specifications – hydraulic models

Model no.	Rated working load <sup>(2)</sup>		Maximum speed <sup>(3)</sup>		Rec'd rope dia		Maximum working flow		Working pressure		Weight w/rope	
	lbs	kg	fpm	m/min	in.	mm	gpm	l/min	psi	bar	lbs	kg
LS500HLP	1100	500	98	30	1/2	13	6.3	24	1499	105	638	290
LS1000HLP	2200	1000	98	30	1/2	13	9.8	37	1785	125	638	290

- (1) For hydraulic models: at last (4th) rated layer
- (2) For pneumatic models: at rated load
- (3) For pneumatic models: at mid-drum with rated load

### Performance

13 mm rope at 1499 psi (105 bar) 6.3 gpm (24 l/min)

Model no.	Rated layers	Line pull		Line speed	
		lbs	kg	fpm	m/min
LS500HLP	1	1397	635	77.1	23.5
	2	1283	583	84.3	25.7
	3	1184	538	91.2	27.8
	4	1100	500	98.4	30.0

13 mm rope at 1785 psi (125 bar) 9.8 gpm (37 l/min)

Model no.	Rated layers	Line pull		Line speed	
		lbs	kg	fpm	m/min
LS500HLP	1	2794	1270	77.1	23.5
	2	2565	1166	84.3	25.7
	3	2369	1077	91.2	27.8
	4	2200	1000	98.4	30.0

### Dimensions

LS150RLP pneumatic winch in inches (mm)

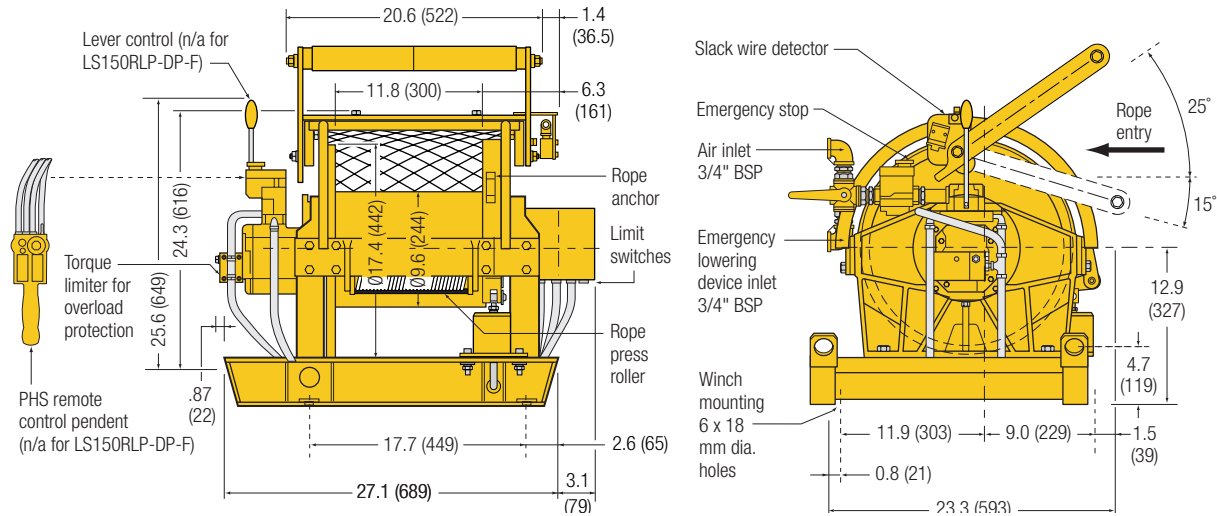

LS500RLP and LS1000RLP pneumatic winches in inches (mm)

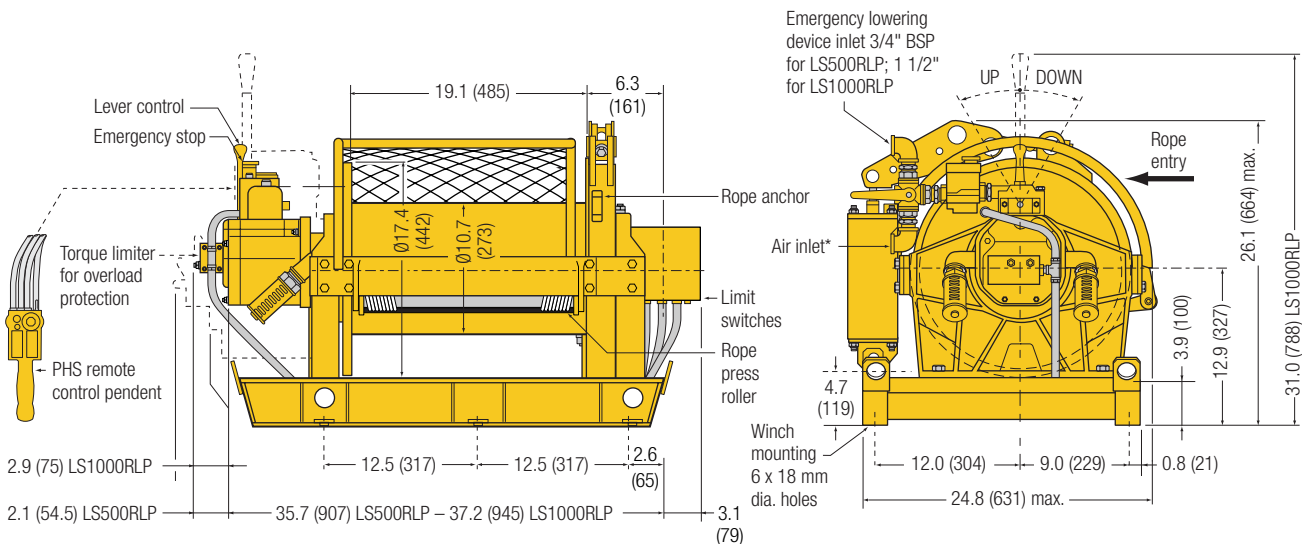

Dimensions are subject to change. Contact factory for certified prints

# Liftstar "Offshore" Man Rider™ Series

## 330 to 2200 lb (150 to 1000 kg) capacity



### Cumulative rope capacity

Model no.	Rec'd rope dia.		Rope capacity according to number of layers <sup>(1)</sup>															
	in.	mm	1		2		3		4		5		6		7		8	
			ft	m	ft	m	ft	m	ft	m	ft	m	ft	m	ft	m	ft	m
<i>Pneumatic models</i>																		
LS150RLP-E	3/8	10	72	22	151	46	233	71	325	99	420	128	522	159	630	192	685	741
LS500RLP	1/2	13	102	31	213	65	335	102	466	142	597	185	754	230	-	-	-	-
LS1000RLP	1/2	13	102	31	213	65	335	102	466	142	597	185	754	230	-	-	-	-
<i>Hydraulic models</i>																		
LS500HLP	1/2	13	102	31	213	65	335	102	466	142	597	185	754	230	-	-	-	-
LS1000HLP	1/2	13	102	31	213	65	335	102	466	142	597	185	754	230	-	-	-	-

(1) Figures in bold type correspond to layers rated for personnel lifting.

### Dimensions

LS500RLP and LS1000RLP hydraulic winches in inches (mm)

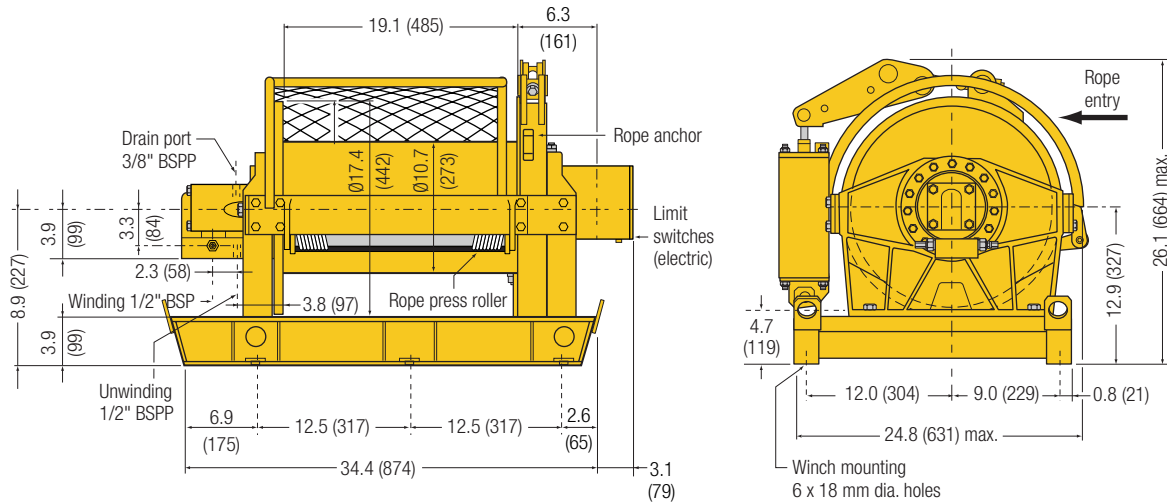

Dimensions are subject to change. Contact factory for certified prints

### How To Order:

Specify complete model code as shown. Specify options in the model code and accessories as a separate line. **Example: LS500RLP-L-S**

Series	Capacity	Power source	Personnel lift	-	Control	Rope take-off	Options
<b>LS</b>	<b>500</b>	<b>R</b>	<b>LP</b>	-	<b>L</b>	<b>L</b>	<b>S</b>
LS = Liftstar winch series	150-E = 150 kg / 330 lbs (Comes standard with European CE package)  500 = 500 kg / 1100 lbs 1000 = 1000 kg / 2200 lbs	R = Air H = Hydraulic (w/o control; brake valve and overload protection flanged as standard)	LP = Includes std features, i.e., second auto brake, skid and drum guard		L = Lever PH = PHS remote pendent (hose length on request; max. length 66 ft / 20 m) DP = Control console with full flow remote control valve (std length 8 ft / 2.5 m)	- = Horizontal B = Vertical (LS150RLP only)	10 = Grooved drum for 10 mm rope 13 = Grooved drum for 13 mm rope E = Emergency lowering system (option for 500 and 1000 kg models; std for all LS150RLP models) R = Press roller S = Upper and lower limit switches (option for 500 and 1000 kg models; std for all LS150RLP models) Y = Slack wire protection (option for 500 and 1000 kg models; std for all LS150RLP models)

**The current design of Force 5 Man Rider air winches has been extended to meet the requirements of the American National Standard, ANSI/ASME A10.22-1990 for “Rope-Guided and Nonguided Worker’s Hoists - Safety Requirements.”**

Man Rider winches, when incorporated into a lifting system as prescribed in the Standard, or by local regulations, are suitable for lifting and lowering people. They are also rated for lifting material without people.

Since this design is to a recognized ANSI / ASME standard, these Man Rider air winches address OSHA requirements where applicable. IR engineering and manufacturing expertise plus third party Type Approval by the American Bureau of Shipping is your assurance of quality, dependability, and conformity.

**■ Standard features**

- All ANSI / ASME Standard Man Riders carry the designation “MRA - Man Rider, ANSI / ASME” in the model code
- Battery powered line speed monitor and payout meter with 120 volt charger
- Display and battery charger enclosures conform to NEMA 13 and JIC standard EGP-1-1967
- Electrical grounding lug
- Dual drum brakes: one automatic and one manual
- Automatic spring return “lift & shift” double action throttle lever prevents accidental starts
- Dual rated at 8:1 design factor for personnel lifting and 5:1 design factor for utility lifting
- Up and down limit switches are easily adjusted and locked to prevent overtravel



FA2MRA24MA1

- Exhaust manifold, ten feet of exhaust hose and muffler are included to keep sound levels below 90 dBA
- Owner’s manual and ANSI / ASME Standard included in weatherproof box attached to winch
- Test certificate verifying performance and required brake holding capacity

**■ Options**

- Different drum lengths
- Remote pilot pendent with overspeed warning light
- Disc brake
- Grooved drum
- Drum guard
- Corrosion resistant marine grade coating system: sandblast to white metal finish and carbozinc primer with a Marine 812 finish
- “Electric-Over-Air” controls for extended remote control operation

**Specifications: performance is based on 90 psi (6.3 bar) air inlet pressure with motor running**

Model no.	Lifting capacity				Stall pull		Required rope size <sup>(1)</sup>		Drum rope storage capacity				Shipping weight	
	Personnel		Utility		lbs	kg	in.	mm	Personnel		Utility		lbs	kg
	lbs	kg	lbs	kg	lbs	kg			ft	m	ft	m	lbs	kg
FA2MRA24MA1	2200	1000	3520	1600	9000	4090	7/16	12	808	246	1000	305	1087	493
FA2.5MRA24MA1	2200	1000	3520	1600	10000	4545	7/16	12	808	246	1000	305	1275	578
FA5MRA24MA1	4400	2000	7040	3200	24000	10909	5/8	16	1024	312	1456	444	2260	1025

(1) Rope construction: Only 6 x 19, 6 x 37 classification, or rotation-resistance ropes, all with IWRC, shall be used.

**Drum speed at third layer (half drum)**

Model no.	At 330 lbs / 136 kg				At personnel rating				At utility rating			
	Up		Down		Up		Down		Up		Down	
	fpm	m/min	fpm	m/min	fpm	m/min	fpm	m/min	fpm	m/min	fpm	m/min
FA2MRA24MA1	95	29.3	52	15.8	91	28	71	22	66	20	120	37
FA2.5MRA24MA1	150	45.7	115	35.1	195	59	136	41	157	48	148	45
FA5MRA24MA1	77	23.5	52	15.8	87	26	69	21	74	22	78	24

All performance specifications are based on rope diameter of 7/16" (11 mm) for FA2MRA and FA2.5MRA and 5/8" (16 mm) diameter for FA5MRA as required to meet ANSI / ASME A10.22 - 1990.



# Force 5™ "Onshore" Man Rider™ Series 2200 and 4400 lb (1000 and 2000 kg) capacity



## Dimensions: ANSI / ASME Man Rider FA2MRA

Drum length		A		B		C		D		E		F	
in.	mm	in.	mm	in.	mm	in.	mm	in.	mm	in.	mm	in.	mm
8.0	203	21.25	540	1.63	41	9.0	229	48.29	1227	9.13	232		
12.0	305	25.25	641	1.38	35	7.5	191	52.29	1328	11.38	289		
16.0	406	29.25	743	1.13	29	9.0	229	56.29	1430	13.63	346		
24.0	610	37.25	945	1.38	35	11.5	292	64.29	1633	17.38	441		
30.0	762	43.25	1099	1.38	35	13.5	343	70.29	1785	20.38	518		

## Dimensions: FA2.5MRA

Drum length		A		B		C		D		E		F	
in.	mm	in.	mm	in.	mm	in.	mm	in.	mm	in.	mm	in.	mm
8.0	203	22.38	568	2.19	56	9.0	229	54.92	1395	8.57	218		
12.0	305	26.38	670	1.68	43	7.5	191	58.92	1497	11.08	281		
16.0	406	30.38	772	1.18	30	9.0	229	62.92	1598	13.68	347		
24.0	610	38.38	975	1.68	43	11.5	292	70.92	1801	17.68	449		
30.0	762	44.38	1127	1.68	43	13.5	343	76.92	1954	20.68	525		

## Wire rope storage capacity <sup>(1), (2)</sup>

Drum length	FA2MRA		FA2.5MRA	
	7/16" ft	12mm m	7/16" ft	12mm m
8	269	82	269	82
12	404	123	404	123
16	539	164	539	164
24	808	246	808	246
30	1010	308	1010	308

- (1) Recommended working capacity is 80% of values shown.
- (2) ANSI / ASME A10.22-1990 requires top layer be 2 in. (50.8 mm) or more below drum flange

Model no.	Sound pressure <sup>(1)</sup>		Avg. air consump.	
	dBa level	scfm	m <sup>3</sup> /min	
FA2MRA	85	335	9.5	
FA2.5MRA	89	700	19.8	
FA5MRA	89	700	19.8	

- (1) Outdoors, at operator, w/exhaust manifold, hose and muffler. Levels can and will vary based on background noise and surroundings.

## FA2MRA in inches (mm)

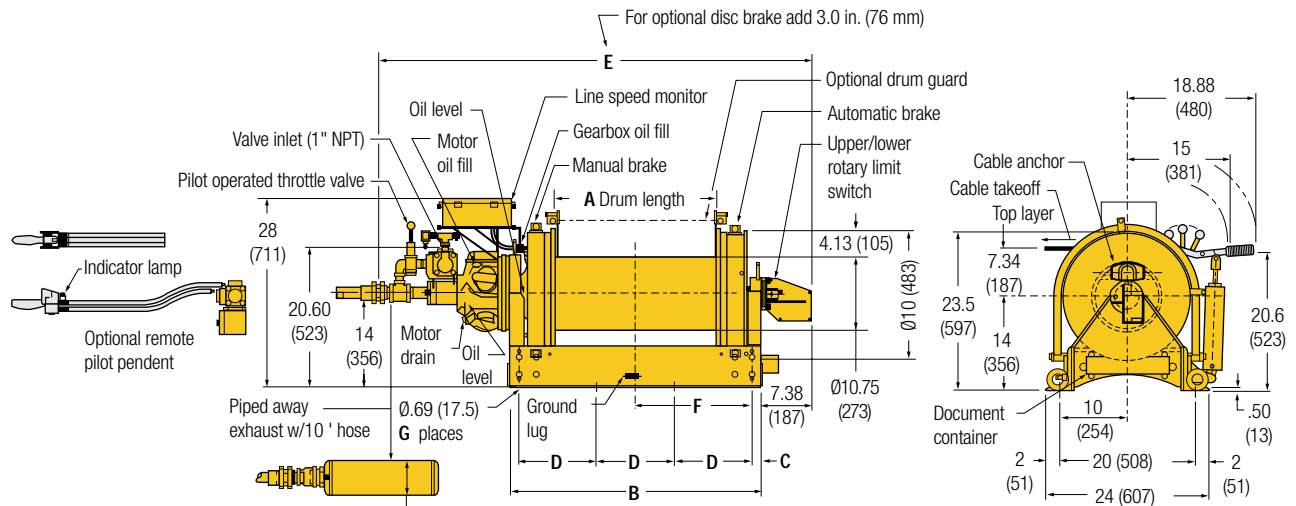

## FA2.5MRA in inches (mm)

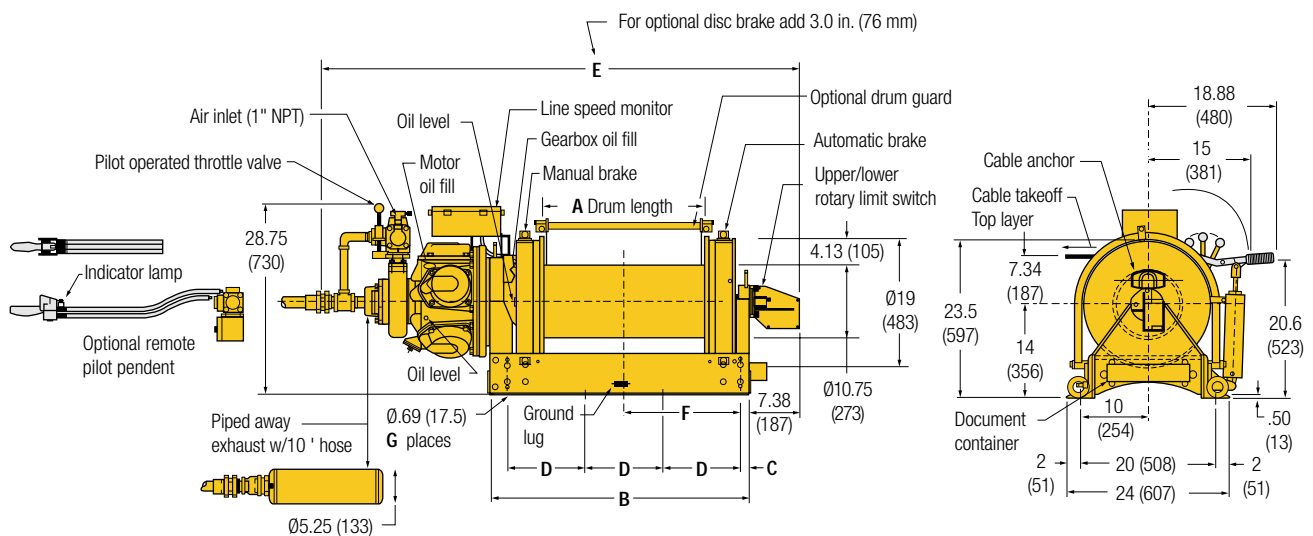

Dimensions are subject to change. Contact factory for certified prints

# Force 5™ "Onshore" Man Rider™ Series 2200 and 4400 lb (1000 and 2000 kg) capacity



## Dimensions: ANSI / ASME Man Rider FA5MRA

Drum length		A		B		C		D		E		F	
in.	mm	in.	mm	in.	mm	in.	mm	in.	mm	in.	mm	in.	mm
8.0	203	26.63	676	1.31	33	8.00	203	50.00	1270	12.00	305		
12.0	305	30.63	778	1.44	37	9.25	235	54.00	1372	13.88	353		
16.0	406	34.63	880	1.56	40	10.50	267	58.00	1473	15.75	400		
24.0	610	42.63	1083	1.81	46	13.50	330	66.00	1676	19.50	495		
30.0	762	48.63	1235	1.31	33	11.50	292	72.00	1829	23.00	584		
36.0	914	54.63	1388	2.31	59	12.50	318	78.00	1981	25.00	635		

## Wire rope storage capacity<sup>(1), (2)</sup>

Series	Drum length		5/8" 16mm	
	in.	mm	ft	m
FA5MRA	8	203	341	104
	12	305	512	156
	16	406	683	208
	24	610	1024	312
	30	762	1280	390
	36	914	1536	468

- (1) Recommended working capacity is 80% of values shown.  
 (2) ANSI / ASME A10.22-1990 requires top layer be 2 in. (50.8 mm) or more below drum flange

## FA5MRA in inches (mm)

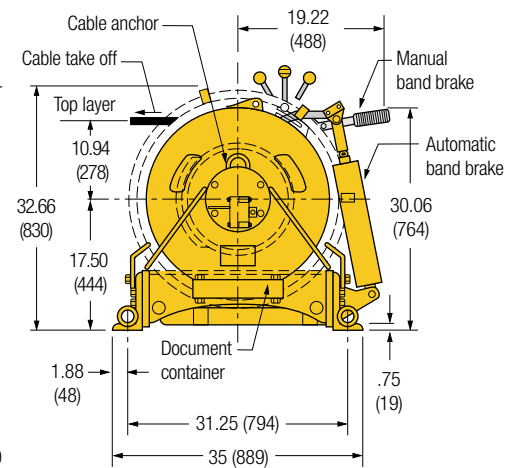
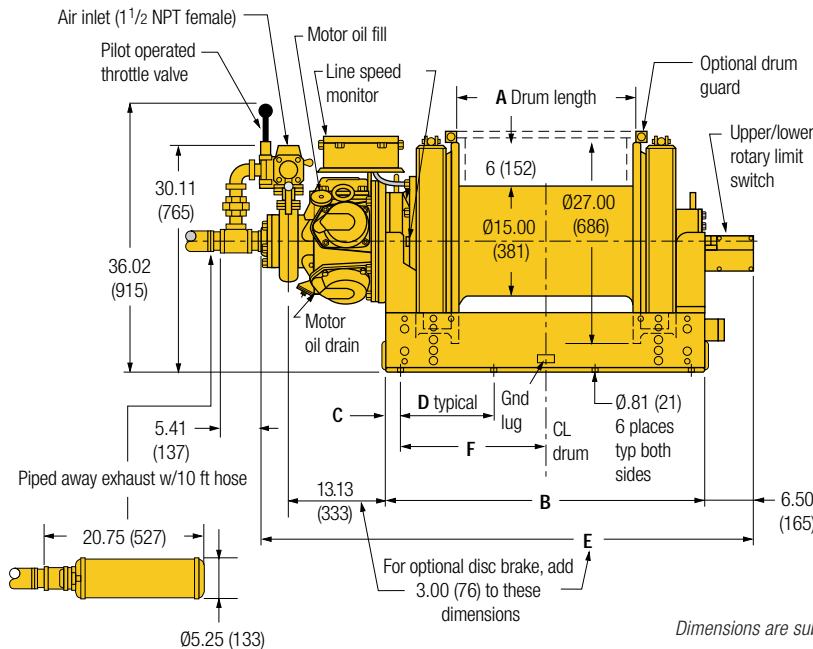

Dimensions are subject to change. Contact factory for certified prints

## How to Order:

Specify winch by complete model number. Man Rider winches will not be sold without standard features. Add options as required. **Example: FA2MRA24MA1G**

Series	Man Rider Capacity	Designation	Drum length	Brakes	Controls	Options
FA	2	MRA	24	MA	1	G
FA	2 = 2200 lbs / 1000 kg 2.5 = 2200 lbs / 1000 kg 5 = 4400 lbs / 2000 kg	MRA = Meets ANSI / ASME A10.22-1990 standard	8 = 8 in. (203mm) 12 = 12 in. (305 mm) 16 = 16 in. (406 mm) 24 = 24 in. (610 mm) (standard) 30 = 30 in. (762 mm) 36 = 36 in. (914 mm)	M = Manual drum (standard) A = Auto drum (standard) K = Auto disc (optional)	1 = Standard winch mounted lever throttle 3XX = Remote pilot pendent throttle w/warning light; 6 ft/2m std. Max 50 ft (15 m). 5XX = Remote electric-over air throttle control XX = Specify hose length in feet	
Force Five	FA = Air powered					
					7 = Drum grooving (no. = wire rope size in sixteenths, e.g. 7/16 in.; 7 for FA2 and FA2.5 only; 10 for FA5 only)	
					G = Drum guard	
					P = Marine 812 finish	
					V = Press roller	
					Z = Sandblast and carbozinc primer	

# Natural Gas Powered Winches

## 1000 to 10000 lb (455 to 4545kg) capacity



**The first natural gas powered winches in the world!**

### Models

BU7A-PR .....	1000 lbs
EU-PR .....	2000 lbs
FA2B-LMX1R .....	4000 lbs
FA5A-LMX1R .....	10000 lbs

### Standard features

- Radial piston motor
- Local throttle
- Manual band brake
- Marine grade, corrosion resistant finish
- Free spool clutches on BU7A-PR and EU-PR
- Rated at 90 psig inlet pressure on gas with less than 4% sulfur content. Gas line filtration is recommended.

### Piped away exhaust

The natural gas exhausting from the winch should be routed away from the operator's work area. To accommodate this, all control valve and motor vents are plumbed together to provide a single port for easy attachment to an exhaust line.

### Gas Smart Redesign provides a "gas tight" winch

Modifications to various components such as the crankshaft and motor case allow the addition of **Viton** lip seals. These seals encapsulate the natural gas within a closed loop system consisting of the control valve, motor and exhaust assembly. This prevents the natural gas from contaminating the local environment.

### Natural gas-resistant Viton seals and gaskets used on:

- |                                    |                           |
|------------------------------------|---------------------------|
| • Piston cover gaskets             | • Exhaust cover gasket    |
| • Rotary valve gasket              | • Motor case gasket       |
| • Reverse valve poppet             | • Reverse valve seal      |
| • Auto disc brake on FA2B and FA5A | • Motor output shaft seal |



BU7A-PR



EU-PR



FA2B-LMX1R

### Specifications

Series	Capacity		Line speed	
	lbs	kg	fpm	m/min
BU7A-PR	1000	455	45	14
EU-PR	2000	909	68	21
FA2B-LMX1R	4000	1818	96	29
FA5A-LMX1R	10000	4545	32	10

**BU7A-PR-E, FA2B-LMX1R-E and FA5A-LMX1R-E are fitted as standard with the following CE package:**

- 1 Drum guard
- 2 Emergency stop valve (main air shutoff)
- 3 Exhaust muffler
- 4 CE documentation

**NEW!**

## Hydraulic Winches

1000 to 100000 lb (455 to 45450 kg) capacity



**The IR line of hydraulic winches incorporates over 150 years of the combined engineering and manufacturing experience of Beebe International and the original Ingersoll-Rand line of products.**

IR's hydraulic winches utilize both the advanced design of our new Fulcrum winches and the time proven engineering of our Force 5 series. A hydraulic motor and hydraulically released brakes replace the standard air components. These winches can be provided with a compact skid-mounted hydraulic power pack which can include gas, diesel or electric motors, variable displacement pumps, oil reservoir, heat exchanger, filters and controls. These models offer improved load control, quick response and energy efficiency resulting in operating cost savings.



FH10 with hydraulic Accu-Spool



FH10 hydraulic winch used for automated drill pipe handling system

### ■ **Optional configurations include:**

- Fixed and variable displacement motors available in vane, piston and gear configurations
- Brake choices include automatic disc and drum type devices
- A wide variety of gear ratios and motor horsepower coupled with variable displacement pumps and motors provide a broad range of line pull and line speed combinations.
- Extensive array of drum lengths and flange heights
- IR offers the expertise to incorporate complete control packages for each solution, from a simple local throttle valve to a completely integrated control system.
- Hydraulic power units are built to industry standards or customer supplied specifications.



FH1BMR-SMK1G Man Rider winch



FH5, 5000 lb decoking winch

**NEW!**

## Hydraulic Winches 1000 to 100000 lb (455 to 45450 kg) capacity



### ■ Power unit:

- Each IR hydraulic power unit is skid mounted incorporating an electric motor, with a fixed or variable displacement pump, an oil reservoir, a heat exchanger, filters and controls.
- IR's hydraulic power units can be built to industry standard specifications or custom built to your specifications.

*Hydraulic power unit incorporating twin 75 hp explosion proof electric motors, each powering its own 68 gpm variable displacement pump with common 210 gallon reservoir*



*50 hp electric motor;  
explosion proof hydraulic  
power unit; 39 gpm; 82  
gallon reservoir*

**IR** excels in providing complete system solutions, from upfront engineering through system installation and testing. IR provides the appropriate technological experience to bring together your lifting, pulling, tensioning, and material handling solutions.

## High Capacity Chain Hoists

*The IR line of high capacity chain hoists incorporates over 75 years of experience in solving the most challenging lifting applications in the world's toughest industries.*

*Why choose a high capacity chain hoist?*

- Space-saving, compact designs can replace manual chain hoists in industrial applications
- Time proven, rugged and reliable construction provides dependable, long-lasting use
- Flexible designs allow these hoists to be modified to meet your most challenging custom applications
- Variable power sources to meet the most demanding industrial applications
- True vertical lifts
- Excellent spotting characteristics for the most critical applications
- Fail-safe disc brakes
- Zinc plated load chain for corrosion resistance



## **Hercu-Link™ Air Chain Hoist** 5 to 100 metric ton lifting capacity



**IR's uniquely modular, compact design Hercu-Link™ air chain hoist brings strength and durability to maintenance and operations, rigging, construction and shipyard applications with enhanced safety, space, and time savings in mind.**

### ■ **Standard features and equipment**

- Compact design can easily replace older manual chain hoists in many industrial applications
- All steel construction
- True vertical lift in all applications
- Radial piston air motor provides superior spotting control
- Limit switches standard on all Frame 2 models
- Automatic, multi-disc oil bath motor brake
- Compact planetary gearing
- Alloy steel hooks with safety latches and roller thrust bearings
- Alloy steel zinc plated load chain
- Stainless steel pins and fasteners; 3/8" (9.5 mm) and smaller
- Corrosion resistant fasteners; 1/2" (13 mm) and larger
- Water drains provided in enclosed bottom load block
- Lifting lugs for easy installation
- Pendant or pull rope control
- All non-oil bath bearings are regreasable
- Muffler

### ■ **Additional standard equipment for trolley models:**

- Self locking worm gear drive
- Rail sweeps (safety lugs)
- 4 push button pendant control
- Trolley bumpers and guide rollers for Frame 2 models
- Zinc plated hand chain/geared trolleys
- Zinc plated trolley shafts/spacers

### ■ **Options:**

- Hook mounted, plain, geared, and motorized trolley suspensions
- Chain containers
- Accu-Trol pendant (see Accu-Trol section for specifications and ordering information)
- Variable lengths of lift
- 60 psi (4 bar) applications packages
- Main air shut-off (emergency stop)
- Pull rope control
- Limit switches, trolley bumpers, and trolley guide rollers for Frame 1 models
- Spark and corrosion resistant packages
- Rubber hull bumpers
- Hydraulic models
- Underwater models
- Trolley drive disc brake – secondary to worm gear braking action



HA2-025M,  
Frame 2

HA2-050H,  
Frame 2

**For BOP handling systems:  
Please refer to brochure  
MHD55148**

**-E = Compliance with the European Machinery Directive. Hercu-link series hoists will be fitted with the following:**

- 1 Overload protection device
- 2 Emergency stop on pendant
- 3 Main air shut-off valve on air inlet
- 4 Exhaust muffler
- 5 Upper and lower limit switches

**Specifications: performance is based on 105 psi (7 bar) air inlet pressure with motor running**

Model no.	Capacity tons	Standard lift		Hoist lift <sup>(1) (2)</sup>		Hoist lower		Hoist	Avg. air cons.		Chain	Std headroom <sup>(3)</sup>		Unit weight		Ship weight	
		ft	m	ft/min	m/min	ft/min	m/min	hp	cfm	m <sup>3</sup> /min	falls	in.	mm	lbs	kg	lbs	kg
<b>Frame 1/hook mounted hoist (16 mm chain)</b>																	
HA1-005H	5	10	3	10	3	15	4.6	3.8	165	4.7	1	27.63	702	520	236	670	304
HA1-010H	10	10	3	5	1.5	7.5	2.3	3.8	165	4.7	2	35.50	902	610	277	760	345
HA1-015H	15	10	3	3.25	1	5	1.5	3.8	165	4.7	3	41.88	1064	875	398	1125	511
HA1-020H	20	10	3	2.5	.76	3.75	1.1	3.8	165	4.7	4	42.50	1080	975	443	1275	580
<b>Frame 2/hook mounted hoist (22 mm chain)</b>																	
HA2-012H	12.5	10	3	8	2.4	12	3.7	9.4	280	8	1	38.50	978	965	439	1215	552
HA2-025H	25	10	3	4	1.2	6	1.8	9.4	280	8	2	51.13	1299	1235	561	1685	766
HA2-037H	37.5	10	3	2.5	.76	3.75	1.1	9.4	280	8	3	66.50	1689	2230	1014	2680	1218
HA2-050H	50	10	3	2	.61	3	0.9	9.4	280	8	4	75.06	1907	2955	1343	3330	1514
<b>Frame 3/hook mounted hoist (32 mm chain)</b>																	
HA3-075H	75	10	3	2.5	0.76	2.5	0.76	25	500	14.3	3	83	2108	7600	3453	8450	3839
HA3-100H	100	10	3	2	0.61	2	0.61	25	500	14.3	4	96	2432	8000	3635	8850	4021
<b>Frame 1/trolley mounted hoist (16 mm chain)</b>																	
HA1-005M (or V)	5	10	3	10	3	15	4.6	3.8	165	4.7	1	23.56	598	905	411	1055	480
HA1-010M (or V)	10	10	3	5	1.5	7.5	2.3	3.8	165	4.7	2	30.50	775	1105	502	1305	593
HA1-015M (or V)	15	10	3	3.25	1	5	1.5	3.8	165	4.7	3	35.25	895	1315	598	1565	711
HA1-020M (or V)	20	10	3	2.5	.76	3.75	1.1	3.8	165	4.7	4	34.96	878	1425	648	1725	784
<b>Frame 2/trolley mounted hoist (22 mm chain)</b>																	
HA2-012M (or V)	12.5	10	3	8	2.4	12	3.7	9.4	280	8	1	24.69	627	1415	643	1665	757
HA2-025M (or V)	25	10	3	4	1.2	6	1.8	9.4	280	8	2	40.94	1040	1660	755	2110	959
HA2-037M (or V)	37.5	10	3	2.5	.76	3.75	1.1	9.4	280	8	3	48.94	1243	3700	1682	4150	1886
HA2-050M (or V)	50	10	3	2	.61	3	0.9	9.4	280	8	4	53.00	1346	4665	2120	5440	2473
<b>Frame 3/trolley mounted hoist (32 mm chain)</b>																	
HA3-075M	75	10	3	2.5	0.76	2.5	0.76	25	500	14.3	3	(4)	(4)	(4)	(4)	(4)	(4)
HA3-100M	100	10	3	2	0.61	2	0.61	25	500	14.3	4	(4)	(4)	(4)	(4)	(4)	(4)

- (1) Chain bucket dimensions vary per length of lift. Contact technical sales for specific requirements.
- (2) Lifting speed will be reduced when 4-bar gearing (option Q) is ordered.
- (3) Headroom for plain and geared trolleys are the same as motorized trolley.
- (4) Contact factory for specific trolley configuration.
- (5) Air Inlet Sizes: Frame 1, 3/4"  
Frame 2, 1"  
Frame 3, 1-1/2"

**Hercu-Link Frame 2 operating data at 105 psi/7 bar (dynamic)**

Series	at rated load				at half load				at no load			
	Up		Down		Up		Down		Up		Down	
	fpm	m/min	fpm	m/min	fpm	m/min	fpm	m/min	fpm	m/min	fpm	m/min
HA2-012H	7	2.1	16	4.9	13	4.0	11.5	3.5	19	5.8	7	2.1
HA2-025H	3.5	1.1	8	2.4	6.5	2.0	5.7	1.7	9.5	2.9	3.5	1.1
HA2-037H	2.3	.07	5.3	1.6	4.3	1.3	3.8	1.2	6.3	1.9	2.3	0.7
HA2-050H	1.7	.05	4	1.2	3.2	1.0	2.9	0.9	4.75	1.4	1.75	0.5

Performance figures are based on 1-1/4 inch (32 mm) I.D. air hose. Air consumption at no load is 280 cfm (7.84 m<sup>3</sup>/min); at half load is 215 cfm (6.02 m<sup>3</sup>/min) and at rated load is 150 cfm (4.2 m<sup>3</sup>/min);



# Hercu-Link™ Air Chain Hoist

5 to 100 metric ton lifting capacity



## Dimensions: hook mounted hoist

Frame 1	A <sup>(1)</sup>		B		C		F		G		H		J <sup>(1)</sup>		K	
	in.	mm	in.	mm	in.	mm	in.	mm	in.	mm	in.	mm	in.	mm	in.	mm
HA1-005H	27.63	702	13.00	330	—	—	1.81	46	19.00	483	14.88	378	31.25	794	7.75	197
HA1-010H	35.50	902	13.00	330	—	—	2.63	67	19.00	483	14.88	378	40.06	1018	7.75	197
HA1-015H	41.88	1064	19.00	483	—	—	3.00	76	19.00	483	14.88	378	47.88	1216	7.75	197
HA1-020H	42.50	1080	13.00	330	—	—	3.63	92	21.25	540	16.75	425	49.75	1264	7.75	197

	L		M		N		P		Y	
HA1-005H	5.00	127	3.50	89	3.50	89	7.88	48	6.50	165
HA1-010H	5.00	127	6.00	152	8.50	216	2.50	64	8.69	221
HA1-015H	5.00	127	5.25	133	10.00	254	3.38	86	11.00	279
HA1-020H	5.00	127	9.38	238	8.50	216	4.00	102	13.63	346

(1) For Frame 1 models w/limit switch option, add approx. 1.5" to dimensions A and J.

Frame 2	A		B		C		F		G		H		J		K	
	in.	mm	in.	mm	in.	mm	in.	mm	in.	mm	in.	mm	in.	mm	in.	mm
HA2-012H	38.50	978	18.75	476	24.50	622	2.63	67	19.50	495	14.25	362	43.75	1111	9.63	244
HA2-025H	51.13	1299	18.75	476	24.50	622	3.63	92	19.50	495	14.25	362	58.38	1482	9.63	244
HA2-037H	66.50	1689	18.75	476	24.50	622	5.06	129	22.50	572	14.25	362	76.63	1946	9.63	244
HA2-050H	75.06	1907	18.75	476	24.50	622	6.69	170	22.50	572	14.25	362	88.44	2246	9.63	244

	L		M		N		P		Y	
HA2-012H	9.88	251	4.50	114	4.50	114	2.50	64	8.69	221
HA2-025H	9.88	251	6.88	175	11.25	286	3.25	83	13.63	346
HA2-037H	9.88	251	11.13	283	11.25	286	4.25	108	15.06	383
HA2-050H	9.88	251	12.63	321	11.25	286	6.50	165	20.63	524

Frame 3	A		B		C		F		G		H		J		K	
	in.	mm	in.	mm	in.	mm	in.	mm	in.	mm	in.	mm	in.	mm	in.	mm
HA3-075H	94.43	2398	26.00	660	29.75	756	6.69	170	36.21	920	28.69	729	107.81	2738	12.68	322
HA3-100H	96.00	2438	26.00	660	29.75	756	6.69	190	36.21	920	28.69	729	110.96	2818	12.68	322

## Hook mounted hoist with optional filter-lubricator

Frame 1: HA1-005H, HA1-010H, HA1-015H, HA1-020H

Frame 2: HA2-012H, HA2-025H, HA2-037H, HA2-050H

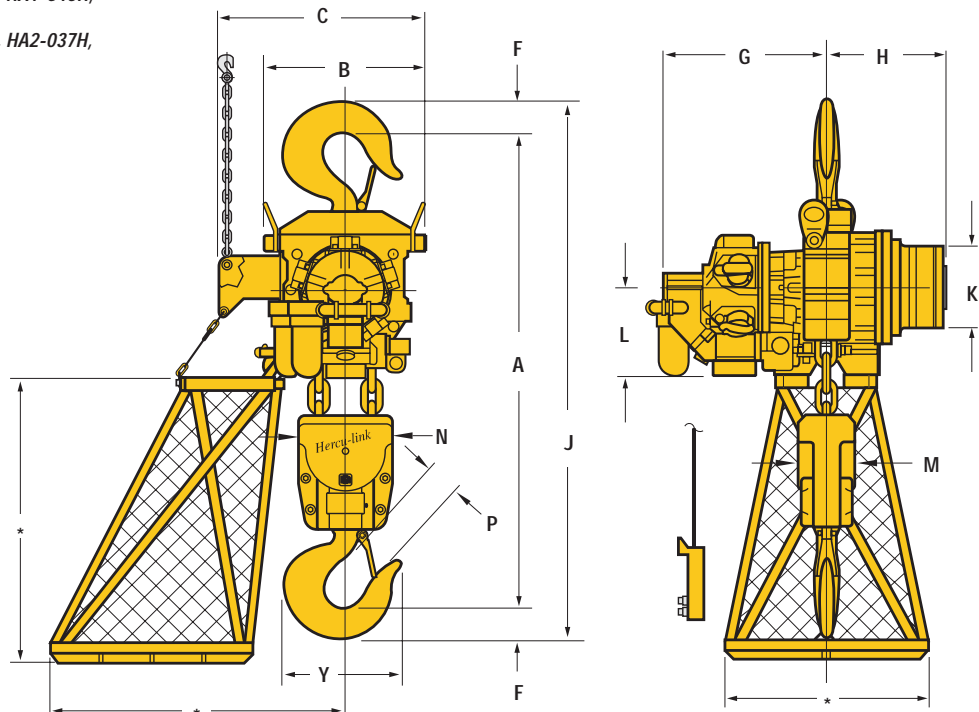

Dimensions are subject to change. Contact factory for certified prints

**Trolley specifications**

Model no.	Capacity tons	Speed		Flange adj		Wheel tread dia		Wheel loading/pair		Min inside curve radius <sup>(1)</sup>		Air cons. <sup>(2)</sup>
		fpm	m/min	in	mm	in.	mm	lbs	kg	in.	mm	cfm m <sup>3</sup> /min
<b>Frame 1 (16 mm chain)</b>												
HA1-005M (or V)	5	40 <sup>4</sup> (20) <sup>5</sup>	12.2 (6.1)	6 – 8	152 – 203	6.13	156	5953	2706	60 <sup>(3)</sup>	1524 <sup>(3)</sup>	See note 2
HA1-010M (or V)	10	40 (20)	12.2 (6.1)	6 – 8	152 – 203	6.13	156	11553	5251	60 <sup>(3)</sup>	1524 <sup>(3)</sup>	See note 2
HA1-015M (or V)	15	40 (20)	12.2 (6.1)	6 – 8	152 – 203	6.88	175	17153	7797	84 <sup>(3)</sup>	2134 <sup>(3)</sup>	See note 2
HA1-020M (or V)	20	40 (20)	12.2 (6.1)	6 – 8	152 – 203	9.00	229	22713	10324	72 <sup>(3)</sup>	1829 <sup>(3)</sup>	See note 2

(1) Minimum curve radius is for frame 1 trolley model without guide rollers. Contact technical sales for trolley with guide rollers.

(2) 180 cfm (5.1 m<sup>3</sup>/min) for vane motor trolley; 75 cfm (2.1 m<sup>3</sup>/min) for piston motor trolley

(3) Without trailing trolley or with articulated trailing trolley

(4) Piston motor trolley

(5) Vane motor trolley

**Dimensions: trolley mounted hoist**

Frame 1	A <sup>(1)</sup>		B		C		D		E		F		G		H	
	in.	mm	in.	mm	in.	mm	in.	mm	in.	mm	in.	mm	in.	mm	in.	mm
HA1-005M	23.56	598	26.44	672	3.88	98	–	–	7.75	197	1.81	46	19.00	483	14.88	378
HA1-010M	30.50	775	26.44	672	3.88	98	–	–	7.75	197	2.59	66	19.00	483	14.88	378
HA1-015M	35.25	895	27.50	699	4.50	114	–	–	9.00	229	3.00	76	19.00	483	14.88	378
HA1-020M	34.56	878	32.00	813	5.88	149	–	–	11.75	298	3.63	92	21.25	540	16.75	425
	J <sup>(1)</sup>		K		L		M		N		O		P		Q	
HA1-005M	36.00	914	7.75	197	5.00	127	3.50	89	3.50	89	10.06	256	1.88	48	6.13	156
HA1-010M	43.75	1111	7.75	197	5.00	127	6.00	152	8.50	216	10.06	256	2.50	64	6.13	156
HA1-015M	48.75	1238	7.75	197	5.00	127	5.25	133	10.00	254	10.75	273	3.38	86	6.13	156
HA1-020M	50.19	1275	7.75	197	5.00	127	9.44	238	8.50	216	12.19	310	4.00	102	9.00	229
	R		S		T		W		X <sup>(2)</sup>		Y		Z			
HA1-005M	7.25	184	2.63	67	1.94	49	19.81	503	8.75	222	6.50	165	–	–		
HA1-010M	7.25	184	2.63	67	1.94	49	19.81	503	8.75	222	8.69	221	–	–		
HA1-015M	8.63	219	3.25	83	2.56	65	20.00	508	8.88	225	11.00	279	–	–		
HA1-020M	11.63	295	3.06	78	2.19	56	19.50	495	6.00	152	13.63	346	–	–		

(1) For Frame 1 models with the limit switch option, add approximately 1.5" to dimensions A and J.

(2) Chain bucket includes trailing trolley on HA1-015M and any other model with 35 feet (10.7 m) of lift or more.

**Important:**  
It is the user's responsibility to specify proper beam size for the maximum wheel loading. Consult with a qualified engineer.

**4-wheel motorized trolley with optional limit switch**  
Frame 1: HA1-005M, HA1-010M, HA1-015M, HA1-020M  
Frame 2: HA2-012M (see following page for Frame 2 dimensions)

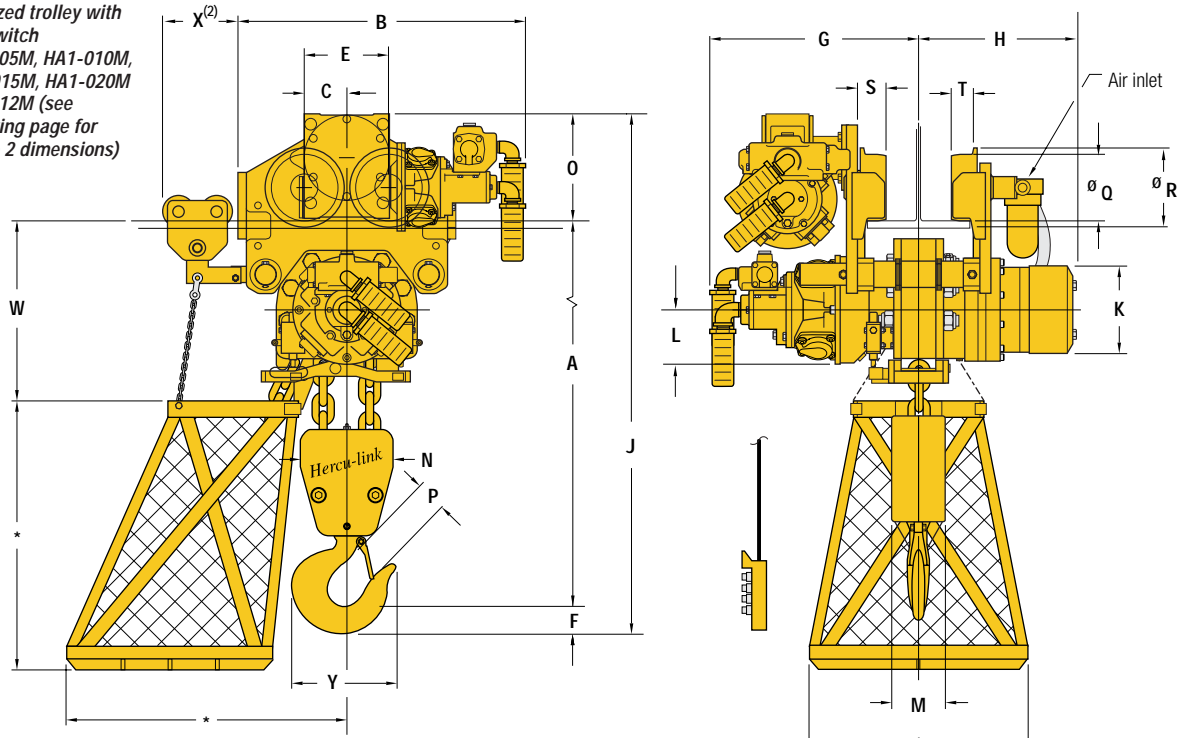

Dimensions are subject to change. Contact factory for certified prints

# Hercu-Link™ Air Chain Hoist

## 5 to 100 metric ton lifting capacity



### Trolley specifications

Model no.	Capacity tons	Speed		Flange adj		Wheel tread dia		Wheel loading/pair		Min inside curve radius		Air cons. (1)	
		fpm	m/min	in	mm	in.	mm	lbs	kg	in.	mm	cfm	m <sup>3</sup> /min
<b>Frame 2 (22 mm chain)</b>													
HA2-012M (or V)	12.5	40 <sup>2</sup> (20) <sup>3</sup>	12.2 (6.1)	6 – 8	152 – 203	6.88	175	14458	6572	72	1829	See note 1	
HA2-025M (or V)	25	40 (20)	12.2 (6.1)	6 – 8	152 – 203	6.88	175	14165	6439	n/a	n/a	See note 1	
HA2-037M (or V)	37.5	40 (20)	12.2 (6.1)	8 – 10	203 – 254	9.00	229	21550	9795	n/a	n/a	See note 1	
HA2-050M (or V)	50	40 (20)	12.2 (6.1)	8 – 10	203 – 254	9.00	229	28666	13030	n/a	n/a	See note 1	

(1) 180 cfm (5.1 m<sup>3</sup>/min) for vane motor trolley; 75 cfm (2.1 m<sup>3</sup>/min) for piston motor trolley

(2) Piston motor trolley

(3) Vane motor trolley

### Dimensions: trolley mounted hoist

Frame 2	A		B		C		D		E		F		G		H	
	in.	mm	in.	mm	in.	mm	in.	mm	in.	mm	in.	mm	in.	mm	in.	mm
HA2-012M	35.88	911	29.50	749	4.50	114	–	–	9.00	229	2.56	65	19.50	495	14.25	362
HA2-025M	40.94	1040	61.75	1568	22.75	578	24.25	616	9.00	229	3.63	92	19.50	495	14.25	362
HA2-037M	48.94	1243	64.88	1648	24.00	610	26.50	673	11.75	298	5.06	129	22.50	572	17.25	438
HA2-050M	53.00	1346	64.88	1648	18.13	460	27.13	689	11.75	298	6.50	165	22.50	572	17.25	438
	J		K		L		M		N		O		P		Q	
HA2-012M	49.25	1251	9.63	244	9.88	251	4.50	114	4.50	114	10.75	273	2.50	64	6.88	175
HA2-025M	56.00	1422	9.63	244	9.88	251	6.88	175	11.25	286	11.44	291	4.00	102	6.88	175
HA2-037M	67.00	1702	9.63	244	9.88	251	11.13	283	11.25	286	13.00	330	4.75	121	9.00	229
HA2-050M	72.50	1842	9.63	244	9.88	251	12.63	321	11.25	286	13.00	330	6.50	165	9.00	229
	R		S		T		W		X (1)		Y		Z			
HA2-012M	8.63	219	3.25	83	2.56	65	24.44	697	8.75	222	8.69	221	–	–		
HA2-025M	8.63	219	3.19	81	2.56	65	19.06	484	–	–	13.63	346	27.50	699		
HA2-037M	11.38	289	3.06	78	2.56	56	19.19	487	–	–	15.44	392	24.50	622		
HA2-050M	11.38	289	3.06	78	2.56	56	19.19	487	–	–	20.63	524	24.50	622		

**Important:**  
It is the user's responsibility to specify proper beam size for the maximum wheel loading. Consult with a qualified engineer.

### Frame 3

HA3-075M

HA3-100M

**Contact Technical Sales for product specifications for 75 and 100 ton models.**

(1) Chain bucket includes trailing trolley on HA2-012M and any other model with 35 feet (10.7 m) of lift or more.

### 8-wheel motorized trolley

Frame 2: HA2-025M,  
HA2-037M,  
HA2-050M

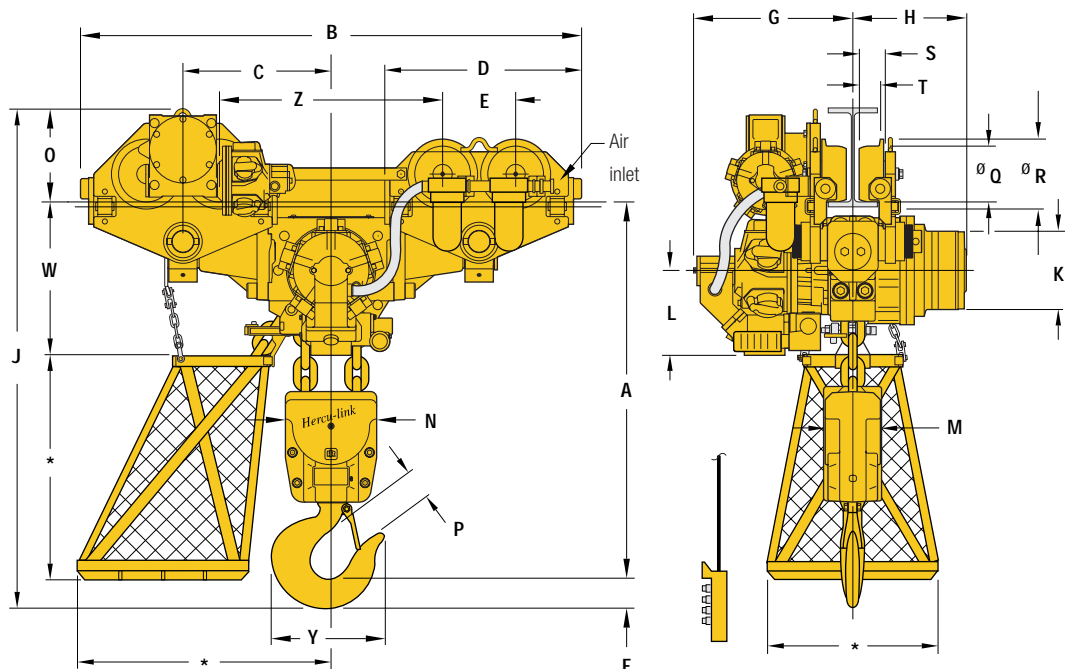

Dimensions are subject to change. Contact factory for certified prints

# Hercu-Link™ Air Chain Hoist

## 5 to 100 metric ton lifting capacity



### How to order standard equipment:

Specify the complete model as shown. Specify beam size, type and flange width. Example: HA1-005MA3-30-27L

Series	Frame size	-	Capacity	Suspension	Trolley flange adj.	Control	-	Lift	-	Control drop	Options																																				
HA	1	-	005	M	A	3	-	30	-	27	L																																				
<p><b>H</b> = Hercu-Link series</p> <p><b>A</b> = Air powered</p> <p><b>H</b> = Hydraulically powered available on request</p> <p>Note: See Electric Hercu-Link section for electric models.</p>			<p><b>H</b> = Hook mount</p> <p><b>C</b> = Clevis mount**</p> <p><b>D</b> = Deck mount**</p> <p><b>P</b> = Plain trolley</p> <p><b>G</b> = Geared trolley</p> <p><b>V</b> = Vane motor trolley</p> <p><b>M</b> = Piston motor trolley</p> <p><b>R</b> = Rack/pinion drive</p> <p>** Mounting information must be supplied.</p>			<p><b>XX</b> = Length of lift</p> <p><b>XX</b> = Control drop pendent (6 ft/2m standard)</p>			<p><b>A</b> = Standard</p> <p><b>B</b> = 2" (50.8 mm) extension</p> <p><b>C</b> = 4" (101.6 mm) extension</p> <p><b>D</b> = 6" (152.4 mm) extension</p> <p><b>M</b> = No trolley used with hook, clevis and deck mount</p>																																						
<table border="1"> <thead> <tr> <th></th> <th>tons</th> <th>lbs.</th> </tr> </thead> <tbody> <tr> <td><b>1 005</b></td> <td>= 5</td> <td>= 11,000</td> </tr> <tr> <td>010</td> <td>= 10</td> <td>= 22,000</td> </tr> <tr> <td>015</td> <td>= 15</td> <td>= 33,000</td> </tr> <tr> <td>020</td> <td>= 20</td> <td>= 44,000</td> </tr> <tr> <td><b>2</b></td> <td></td> <td></td> </tr> <tr> <td>012</td> <td>= 12.5</td> <td>= 27,500</td> </tr> <tr> <td>025</td> <td>= 25</td> <td>= 55,000</td> </tr> <tr> <td>037</td> <td>= 37.5</td> <td>= 82,500</td> </tr> <tr> <td>050</td> <td>= 50</td> <td>= 110,000</td> </tr> <tr> <td><b>3</b></td> <td></td> <td></td> </tr> <tr> <td>075</td> <td>= 75</td> <td>= 165,000</td> </tr> <tr> <td>100</td> <td>= 100</td> <td>= 220,000</td> </tr> </tbody> </table>				tons	lbs.	<b>1 005</b>	= 5	= 11,000	010	= 10	= 22,000	015	= 15	= 33,000	020	= 20	= 44,000	<b>2</b>			012	= 12.5	= 27,500	025	= 25	= 55,000	037	= 37.5	= 82,500	050	= 50	= 110,000	<b>3</b>			075	= 75	= 165,000	100	= 100	= 220,000	<p><b>1</b> = Pull rope</p> <p><b>2</b> = 1 motor pendent (2 button)</p> <p><b>3</b> = 2 motor pendent (4 button)</p> <p><b>4</b> = 3 motor pendent (6 button)</p> <p><b>5</b> = 1 motor pendent with on/off</p> <p><b>6</b> = 2 motor pendent with on/off</p> <p><b>7</b> = 3 motor pendent with on/off</p>			<p><b>A</b> = Accu-Trol pendent</p> <p><b>B</b> = Trolley bumpers (Frame 1 only; standard on Frame 2)</p> <p><b>C</b> = Low temperature; please specify in text: -10° C or -20° C</p> <p><b>D</b> = Trolley drive disc brake</p> <p><b>G</b> = Trolley guide rollers (Frame 1 only; standard on Frame 2)</p> <p><b>L</b> = Upper and lower limit switch (Frame 1 only; standard on Frame 2)</p> <p><b>M1</b> = Per DIN 50049/En10204 Para 2.2 "Typicals"</p> <p><b>M2</b> = Per DIN 50049/En10204 Para 3.1b actual per product as purchased</p> <p><b>M3</b> = Per DIN 50049/En10204 Para 3.1b actual per product as delivered in final condition</p> <p><b>N</b> = Special paint; add code option and specify in text</p> <p><b>P</b> = Marine 812 finish</p> <p><b>Q</b> = 60 psi (4 bar) application package</p> <p><b>R</b> = Copper plate S•COR•E package (see description below)</p> <p><b>S</b> = Solid bronze S•COR•E package (see description below)</p> <p><b>T</b> = Galvanized chain container</p> <p><b>Y</b> = Hull bumper (for hook mounted shipyard hoist)</p> <p><b>Z</b> = Sandblast and carbozinc primer only</p>		
	tons	lbs.																																													
<b>1 005</b>	= 5	= 11,000																																													
010	= 10	= 22,000																																													
015	= 15	= 33,000																																													
020	= 20	= 44,000																																													
<b>2</b>																																															
012	= 12.5	= 27,500																																													
025	= 25	= 55,000																																													
037	= 37.5	= 82,500																																													
050	= 50	= 110,000																																													
<b>3</b>																																															
075	= 75	= 165,000																																													
100	= 100	= 220,000																																													

### Accessories

Series	Air inlet size	Filter	Lubricator	Regulator
HA1	¾ in. (19 mm) NPT	F28-06-SK00	L28-06-LK00	R28-06-F0G0-28
HA2	1 in. (25 mm) NPT	F30-08-000	L30-08-000	R30-08-G00

### ■ S•COR•E (Option codes R and S)

- R** = The product will be equipped with zinc plated load chain, copper plated load hook(s) and trolley wheels. Zinc plated hand chain if applicable.
- S** = Up to 20 ton units will be equipped with zinc plated load chain, solid bronze load hook(s) and trolley wheels. Zinc plated hand chain if applicable.

## Liftchain LCA Lube Free Air Hoist Series 1.5 to 100 metric ton lifting capacity



**The Liftchain LCA series is the latest in gear motor air chain hoist design. Setting new standards by offering a modular and compact design, the Liftchain LCA series is intended for tough industrial applications, offshore oil rigs, shipyard construction, petrochemical, refineries, foundries, steel mills, mining, etc....**

The Liftchain LCA series offers standard features that reduce maintenance, increase safety, and provide rugged reliability, enhanced control and superior performance.

The Liftchain LCA is designed in conformance with the requirements set by the FEM standard (classification 1Bm or ISOM3), ISO, and ANSI/ASME B30.16. The CE versions include all the safety features required by the European Machinery Directive.

### Standard features:

- Lube free gear type air motor provides long life, low maintenance and no environmental pollution (not effected by dust and humidity)
- Automatic fail safe, multi-disc oil bath disc brake (no adjustment required)
- Excellent spotting characteristics with the PHS progressive remote pilot pendant or pull rope control (6.5 ft/2 meter control is standard)
- Built in overload protection and main air shut off valve (CE models only) means no loss of headroom. Efficiency and accuracy of the system are excellent
- Emergency stop and reset button on pendant (CE models only) (as per EN 418 standard)
- Top and bottom limit switches are integrated into the hoist body for a more compact design
- All steel/cast iron construction
- Zinc plated load chain for corrosion resistance (10 ft/3 meters standard)
- 5:1 design factor at rated load
- Bottom hook mounted on bearing with external lubrication point
- Integrated exhaust muffler for quieter operation
- Built in retractable handles for easy handling
- Working pressure range of 60 – 100 psi (4 to 7 bar)
- Low air consumption/low maintenance
- Inherently flame and explosion proof design
- Available in hook, plain, geared and motorized trolleys (also lube free) with automatic disc brake

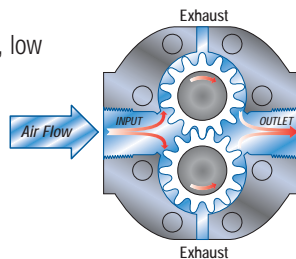

### Options and accessories:

- |   |                              |
|---|------------------------------|
| • Variable lengths of lift and control      | • Chain containers           |
| • Spark and corrosion resistant packages    | • Marine paint               |
| • Articulated trolley for BOP handling      | • Offshore paint (290 μ DFT) |
| • Special mining models                     | • Sandblast and primer       |
| • "Flex" units allow for easy customization | • Hydraulic versions         |

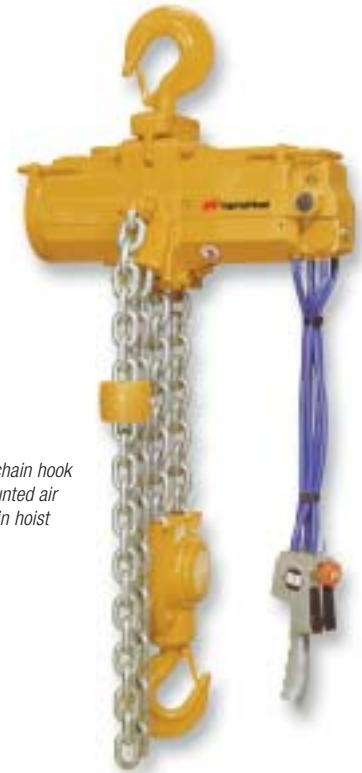

Liftchain hook mounted air chain hoist



Liftchain trolley mounted air chain hoist

# Liftchain LCA Lube Free Air Hoist Series

## 1.5 to 100 metric ton lifting capacity



### Hook mounted hoist specifications at 90 psi (6.3 bar) air inlet pressure with motor running

Model no. (1) (Hoist only)	Cap. metric tons	Chain falls	Lifting speed at rated load		Lifting speed at no load		Lowering speed at rated load		Average air consumption		Standard headroom		Net weight (2)		Wt of chain per m of lift	
			fpm	m/min	fpm	m/min	fpm	m/min	scfm	m <sup>3</sup> /min	in.	mm	lbs	kg	lbs	kg
LCA015SIP or SIC	1.5	1	13.12	4.0	24.6	7.5	21.3	6.5	74	2.1	17.56	446	110	50	3.3	1.5
LCA030DIP or DIC	3	2	6.56	2.0	12.0	3.7	10.5	3.2	74	2.1	23.19	589	132	60	6.6	3.0
LCA030SIP or SIC	3	1	10.5	3.2	19.7	6.0	23.0	7.0	124	3.5	22.80	579	176	80	8.4	3.8
LCA060DIP or DIC	6	2	5.2	1.6	9.8	3.0	11.5	3.5	124	3.5	29.33	745	220	100	16.7	7.6
LCA060SIP or SIC	6	1	5.9	1.8	11.8	3.6	9.8	3.0	124	3.5	29.60	752	286	130	12.5	5.7
LCA120DIP or DIC	12	2	2.95	0.9	5.9	1.8	4.9	1.5	124	3.5	39.02	991	396	180	25.3	11.4
LCA180TIP or TIC	18	3	1.64	0.5	3.28	1.0	3.28	1.0	124	3.5	42.64	1083	484	220	38.0	17.1
LCA250QIP or QIC	25	4	1.31	0.4	2.62	0.8	2.46	0.75	124	3.5	46.46	1180	506	230	50.6	23.0
LCA750TIP or TIC	75															
LCA1000QIP or QIC	100															

Contact Technical Sales for product specifications for 75 and 100 ton models.

(1) SIP = hoist with pendent control; for hook mounted or trolley mounted models. SIC = hoist with pull cord control; for hook mounted models only.  
 (2) Net weights are given with standard lift of 10 ft (3 m) and standard control length of 6.6 ft (2 m).

### Dimensions: hook mounted hoist

LCA015S (1.5 metric ton) in inches (mm)

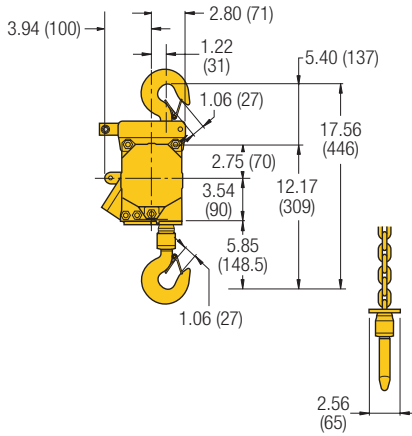

LCA030D (3 metric ton) in inches (mm)

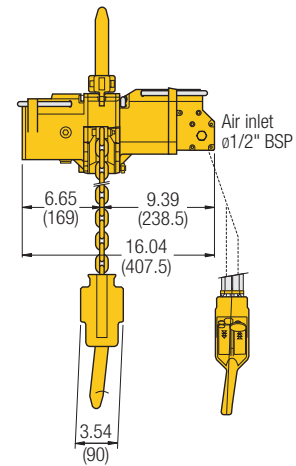
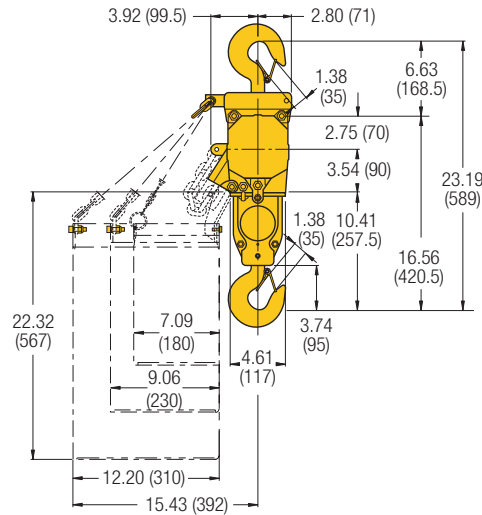

LCA030S (3 metric ton) in inches (mm)

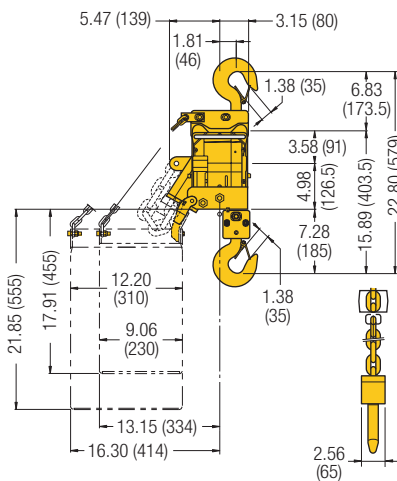

LCA060D (6 metric ton) in inches (mm)

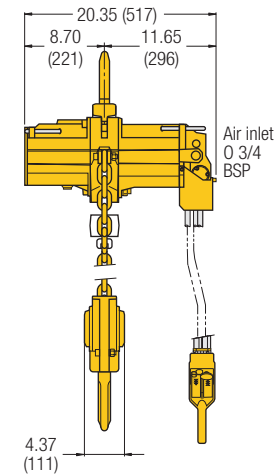
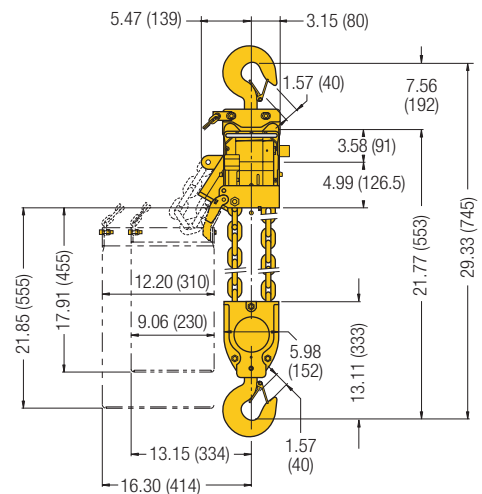

Dimensions are subject to change. Contact factory for certified prints

# Liftchain LCA Lube Free Air Hoist Series

## 1.5 to 100 metric ton lifting capacity



### Dimensions: hook mounted hoist

LCA060S (6 metric ton) and LCA120D (12 metric ton) in inches (mm)

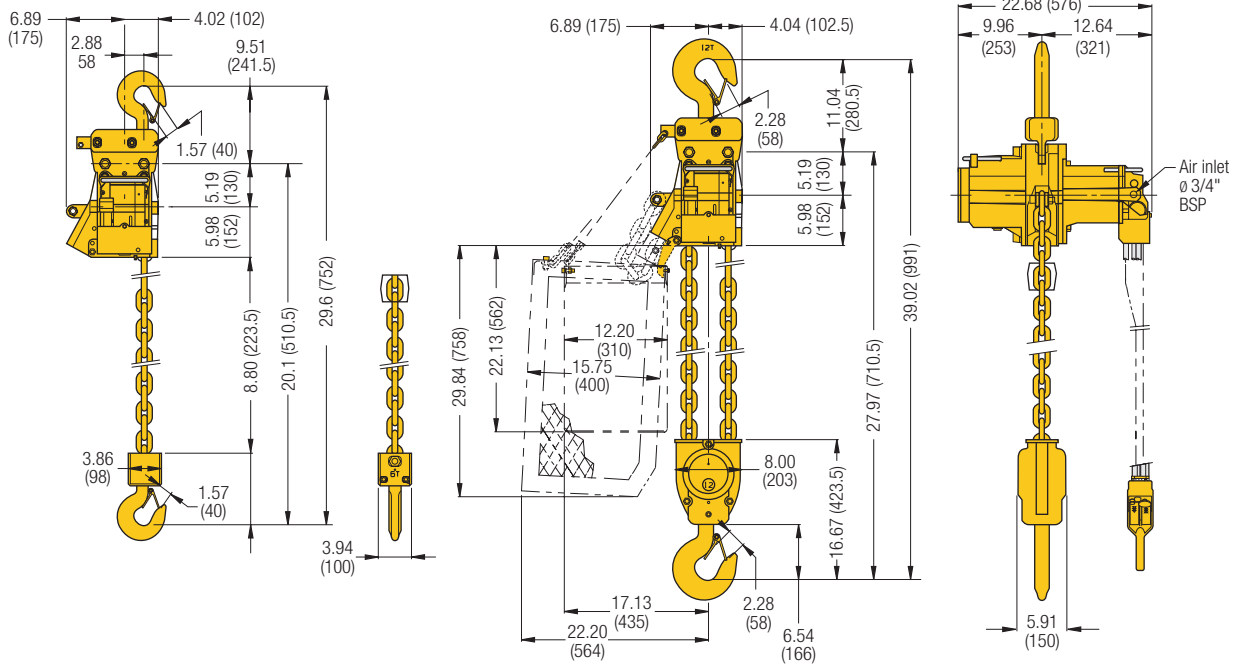

LCA180T (18 metric ton) and LCA250Q (25 metric ton) in inches (mm)

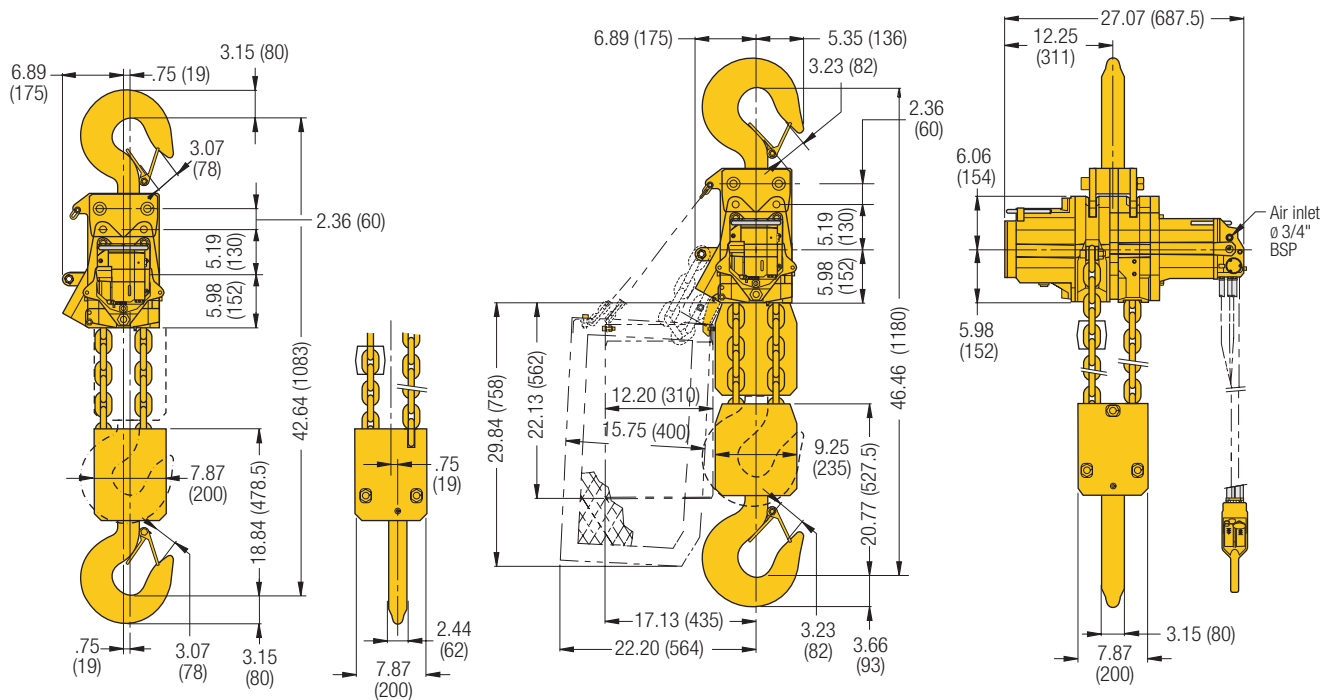

Dimensions are subject to change. Contact factory for certified prints

**Liftchain LCA Lube Free Air Hoist Series**  
**1.5 to 100 metric ton lifting capacity**



**Trolley mounted hoist specifications at 90 psi (6.3 bar) air inlet pressure with motor running**

Model no. (hoist with trolley)	Trolley type	Cap. metric tons	Flange adjustment		Standard headroom		Min. inside curve radius		Max. traverse speed				Average air consumption		Total weight w/std hoist	
			in.	mm	in.	mm	ft	m	with load fpm	no load m/min	with load fpm	no load m/min	scfm	m <sup>3</sup> /min	lbs	kg
LCA015SIP2P	Plain	1.5	3.2-7.9	82-200	17.95	456	3.28	1	-	-	-	-	-	-	187	85
LCA015SIP2G	G geared	1.5	3.2-7.9	82-200	17.95	456	3.28	1	-	-	-	-	-	-	191	87
LCA015SIP2R	Motor	1.5	3.2-7.9	82-200	17.95	456	3.28	1	59.0	18	75.4	23	46	1.3	198	90
LCA030DIP2P	Plain	3	3.2-12.2	82-310	24.7	627.5	6.56	2	-	-	-	-	-	-	253	115
LCA030DIP2G	G geared	3	3.2-12.2	82-310	24.7	627.5	6.56	2	-	-	-	-	-	-	257	117
LCA030DIP2R	Motor	3	3.2-12.2	82-310	24.7	627.5	6.56	2	56.0	17	69.0	21	46	1.3	264	120
LCA030SIP2P	Plain	3	3.2-12.2	82-310	24.15	613.5	6.56	2	-	-	-	-	-	-	341	155
LCA030SIP2G	G geared	3	3.2-12.2	82-310	24.15	613.5	6.56	2	-	-	-	-	-	-	345	157
LCA030SIP2R	Motor	3	3.2-12.2	82-310	24.15	613.5	6.56	2	56.0	17	69.0	21	46	1.3	352	160
LCA060DIP2P	Plain	6	3.7-12.2	98-310	31.08	789.9	9.84	3	-	-	-	-	-	-	446	203
LCA060DIP2G	G geared	6	3.7-12.2	98-310	31.08	789.9	9.84	3	-	-	-	-	-	-	462	210
LCA060DIP2R	Motor	6	3.7-12.2	98-310	31.08	789.9	9.84	3	39.4	12	49.2	15	67	1.9	484	220
LCA060SIP2P	Plain	6	3.7-12.2	98-310	35.1	891.5	9.84	3	-	-	-	-	-	-	557	253
LCA060SIP2G	G geared	6	3.7-12.2	98-310	35.1	891.5	9.84	3	-	-	-	-	-	-	572	260
LCA060SIP2R	Motor	6	3.7-12.2	98-310	35.1	891.5	9.84	3	39.4	12	49.2	15	67	1.9	594	270
LCA120DIP2P	Plain	12	5.1-12.2	131-310	39.51	1003.5	9.84	3	-	-	-	-	-	-	741	337
LCA120DIP2G	G geared	12	5.1-12.2	131-310	39.51	1003.5	9.84	3	-	-	-	-	-	-	759	345
LCA120DIP2R	Motor	12	5.1-12.2	131-310	39.51	1003.5	9.84	3	39.4	12	49.2	15	67	1.9	779	354
LCA180TIP2P	Plain	18	5.6-12.2	143-310	48.78	1239	16.4	5	-	-	-	-	-	-	920	418
LCA180TIP2R	Motor	18	5.6-12.2	143-310	48.78	1239	16.4	5	39.4	12	49.2	15	67	1.9	957	435
LCA250QIP2P	Plain	25	5.6-12.2	143-310	50.69	1287.5	16.4	5	-	-	-	-	-	-	953	433
LCA250QIP2R	Motor	25	5.6-12.2	143-310	50.69	1287.5	16.4	5	39.4	12	49.2	15	67	1.9	990	450

**Dimensions: trolley mounted hoist**

LCA015S (1.5 metric ton) in inches (mm)

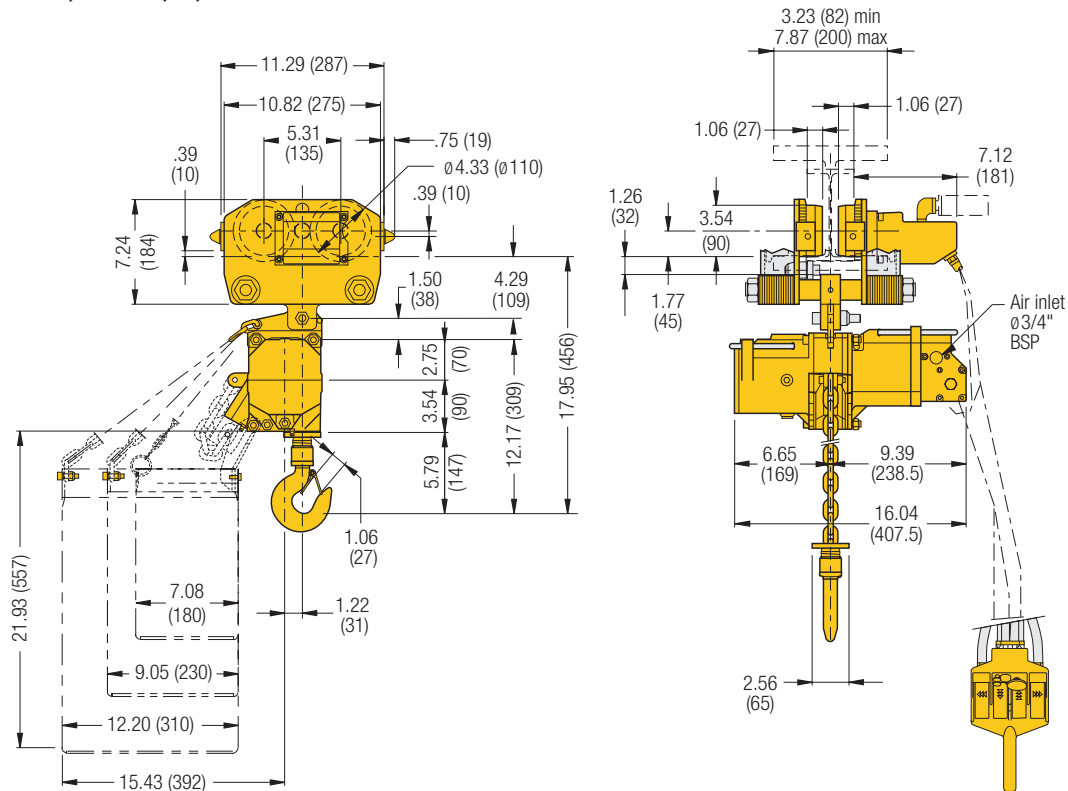

Dimensions are subject to change. Contact factory for certified prints



# Liftchain LCA Lube Free Air Hoist Series

## 1.5 to 100 metric ton lifting capacity



### Dimensions: trolley mounted hoist

LCA030D (3 metric ton) in inches (mm)

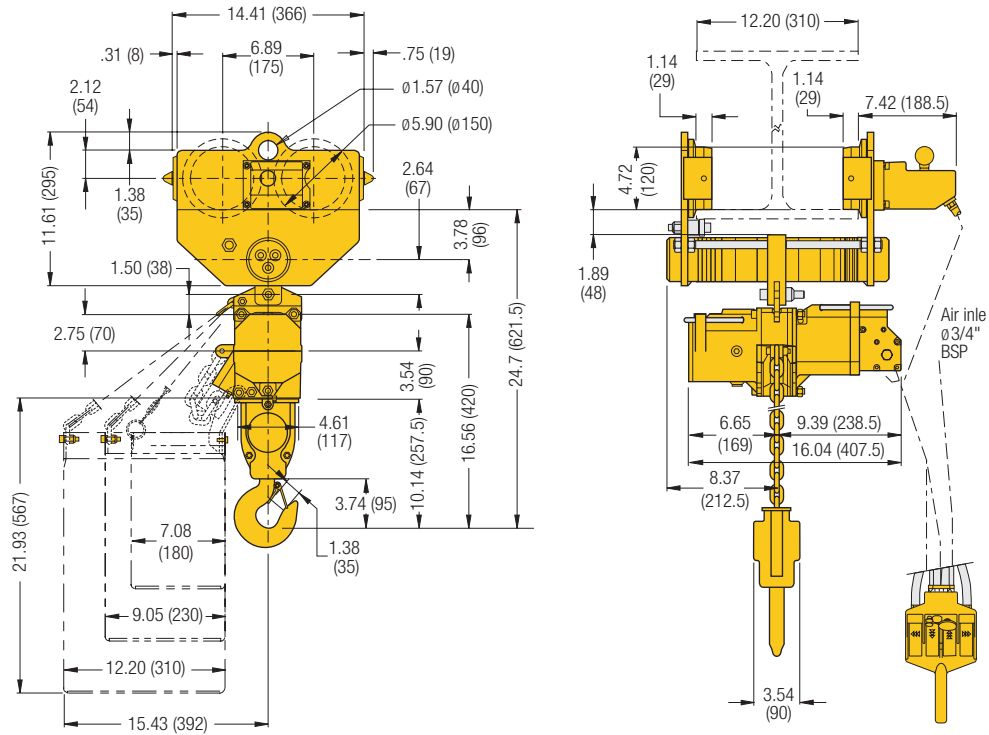

LCA030S (3 metric ton) in inches (mm)

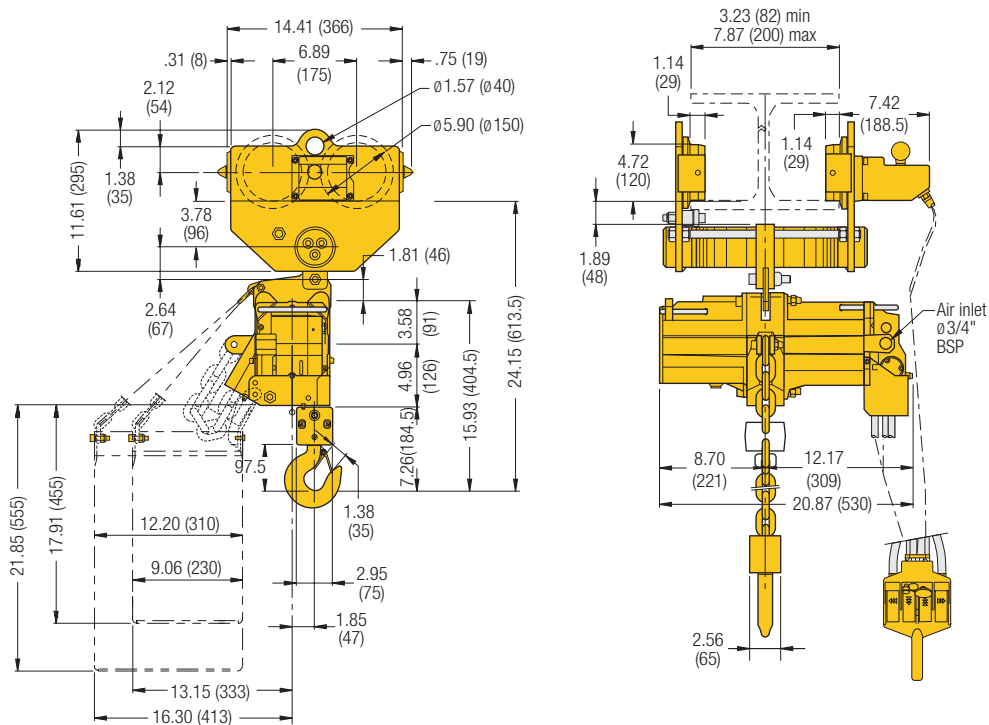

Dimensions are subject to change. Contact factory for certified prints

# Liftchain LCA Lube Free Air Hoist Series

## 1.5 to 100 metric ton lifting capacity



### Dimensions: trolley mounted hoist

LCA060D (6 metric ton) in inches (mm)

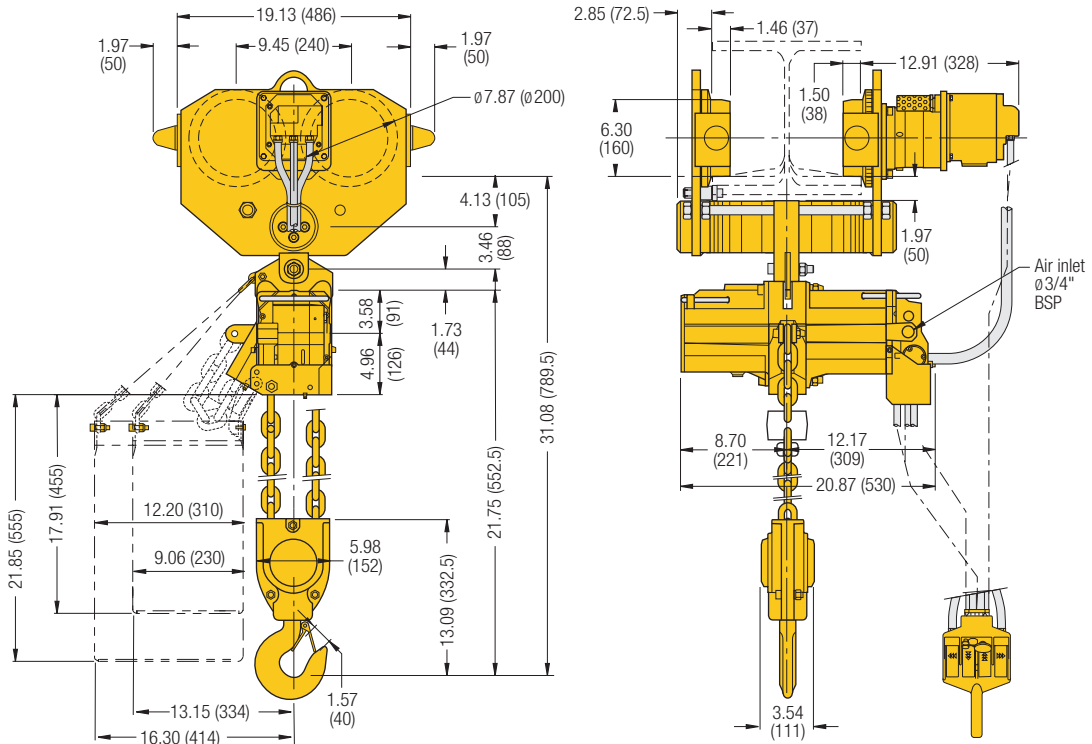

### LCA060S (6 metric ton) in inches (mm)

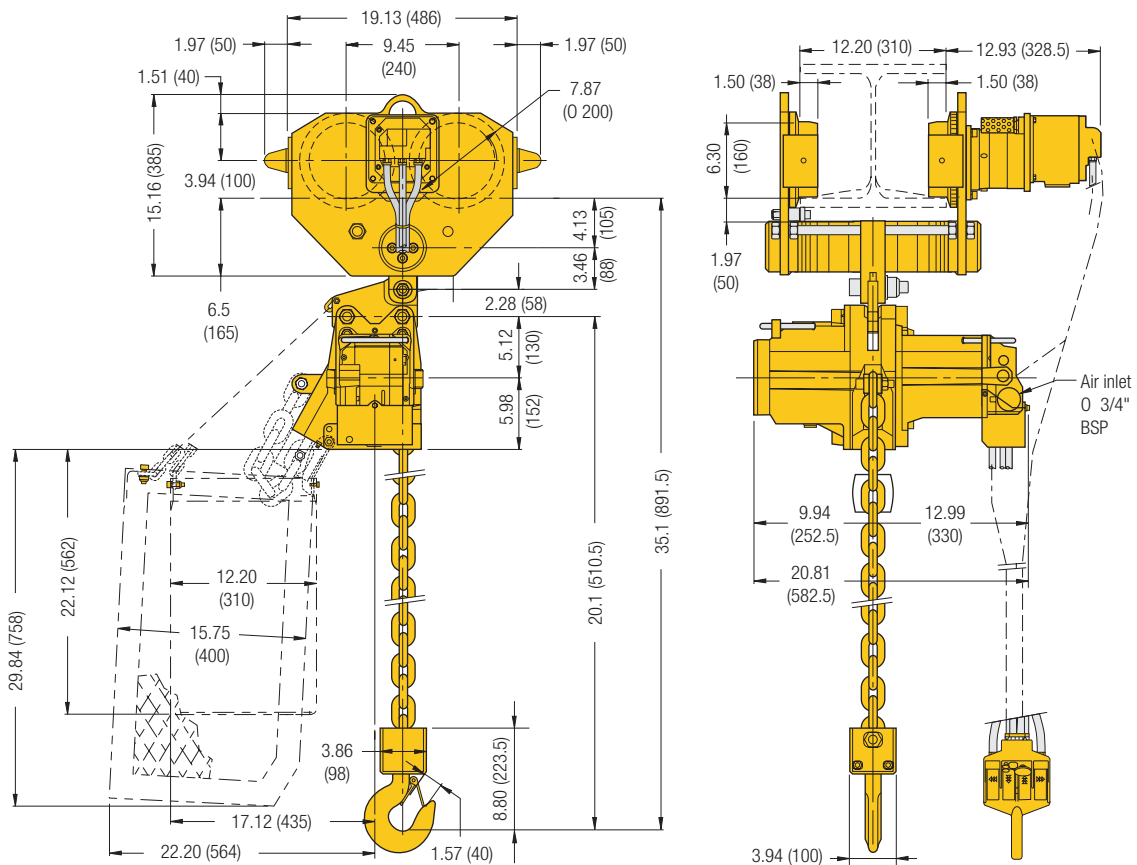

Dimensions are subject to change. Contact factory for certified prints

# Liftchain LCA Lube Free Air Hoist Series

## 1.5 to 100 metric ton lifting capacity



### Dimensions: trolley mounted hoist

LCA120D (12 metric ton) in inches (mm)

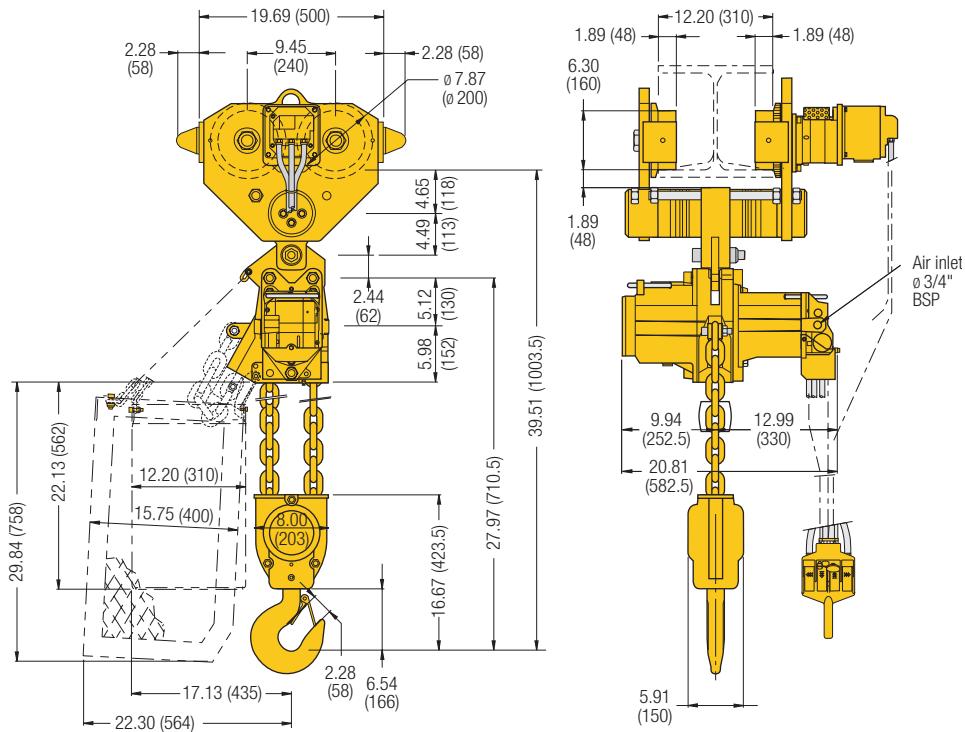

LCA180T (18 metric ton) in inches (mm)

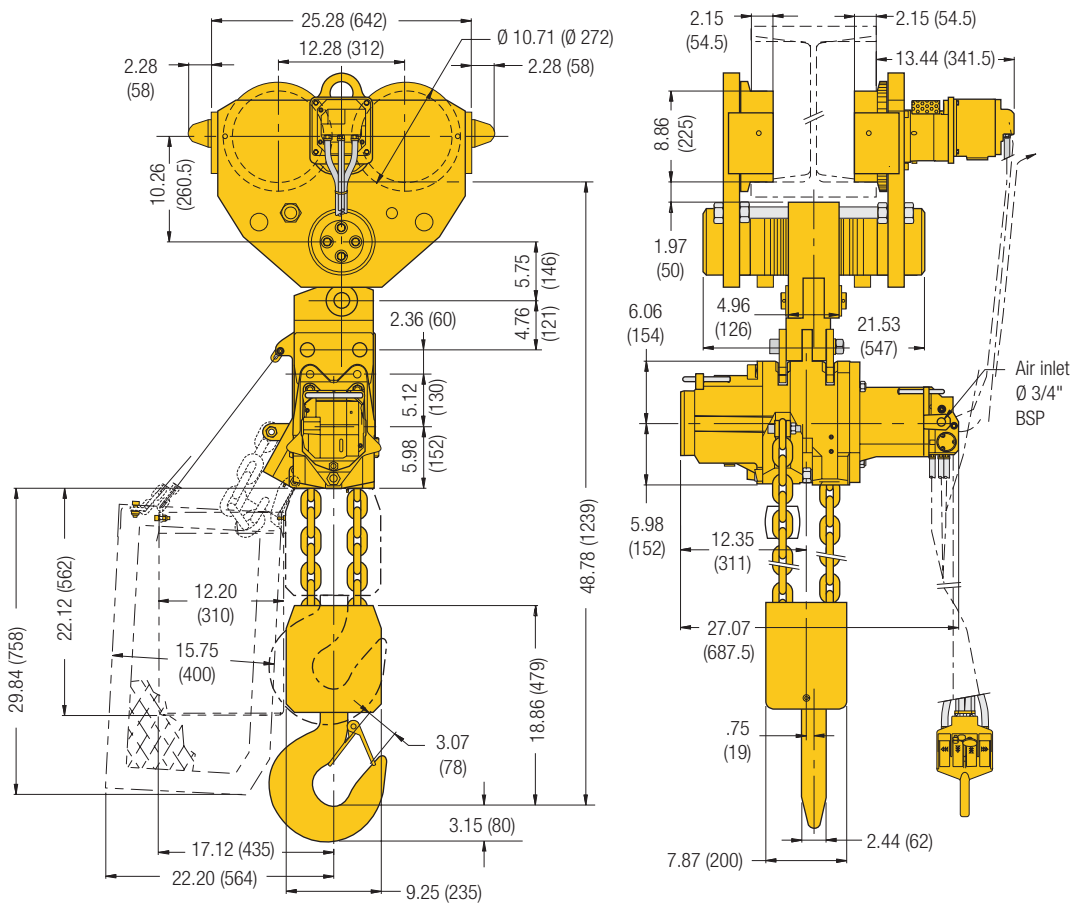

Dimensions are subject to change. Contact factory for certified prints

# Liftchain LCA Lube Free Air Hoist Series

## 1.5 to 100 metric ton lifting capacity



### Dimensions: trolley mounted hoist

LCA250Q (25 metric ton) in inches (mm)

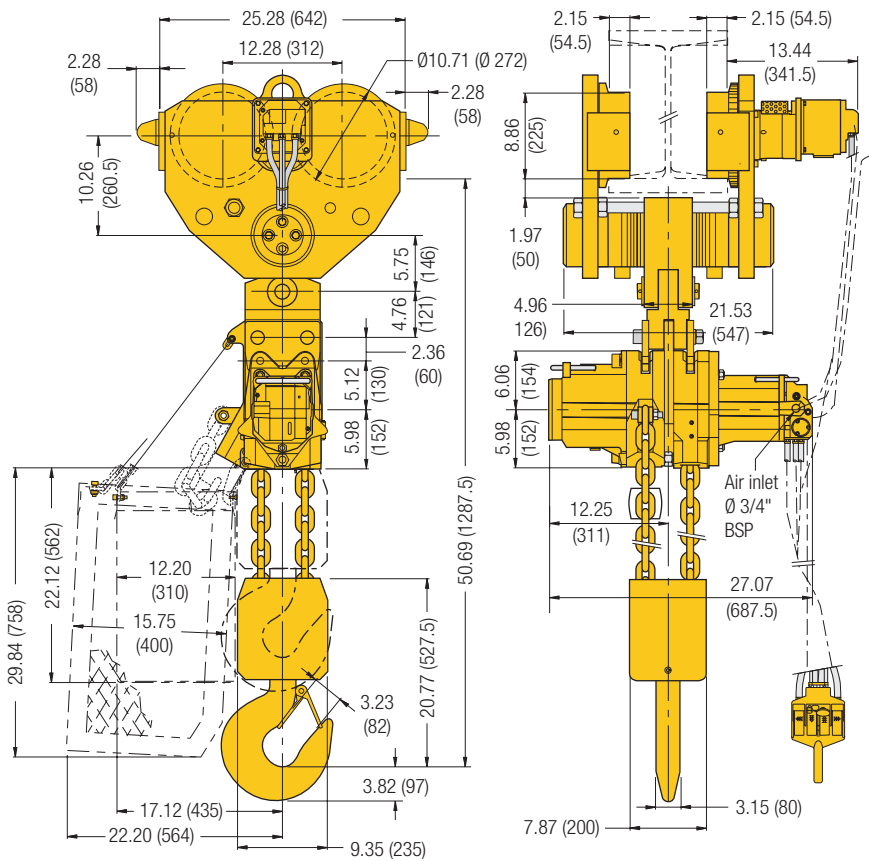

### Pendent handles

Type	Part no.	Dimensions (BSP air inlet)				
		A	B	C	D	E
Single mtr	PHS2E	1/4"	1/4"	-	-	-
Two mtrs	PHS4E	1/4"	1/4"	-	-	1/4"
Single mtr	PHS2E-U	1/4"	1/4"	1/4"	1/4"	-
Two mtrs	PHS4E-U	1/4"	1/4"	1/4"	1/4"	1/4"

Hoist series	Air inlet size
LCA015S & LCA030D	1/2" BSP
LCA030S, 060D, 060S	3/4" BSP
120D, 180T & 250Q	

### PHS2D-U

Single motor pendent handle

Addition of the shaded area is for the  
**PHS4D-U**  
Two motor pendent handle

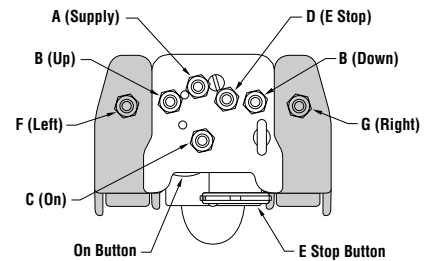

### Chain buckets

Hoist series	Option code/ material	Capacity		Corresponding height of lift				Bucket part no.
		ft	m	ft	m	ft	m	
LCA015S } LCA030D }	A/canvas	39.4	12	39.4	12	19.7	6	CB030D-12M
	B/canvas	98.4	30	98.4	30	49.2	15	CB030D-30M
	C/canvas	196.8	60	196.8	60	98.4	30	CB030D-60M
LCA030S } LCA060D }	A/canvas	39.4	12	39.4	12	19.7	6	CB060D-12M
	B/canvas	98.4	25	82.0	25	41.0	12.5	CB060D-25M
LCA060S } LCA120D }	A/canvas	39.4	12	39.4	12	19.7	6	CB120D-12M
	B/metal	85.3	26	85.3	26	42.6	13	CB120D-26M
LCA180T } LCA250Q }	A/canvas	39.4	12	13.1	4	9.8	3	CB120D-12M
	B/metal	85.3	26	27.9	8.5	21.3	6.5	CB120D-26M

### Link load chain / zinc plated

Hoist series	Bulk part no.	Chain size		Weight per lineal meter	
		dia/pitch in.	mm	lbs	kg
LCA015S LCA030D	LC824-G8ZP	.3x.9	8x24	3.3	1.5
LCA030S LCA060D	LC1336-G8ZP	.5x1.4	13x36	8.47	3.85
LCA060S LCA120D LCA180T LCA250Q	17671	.63x1.8	16x45	12.65	5.75

Dimensions are subject to change.  
Contact factory for certified prints

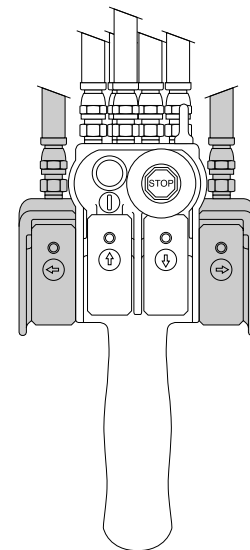

# Liftchain LCA Lube Free Air Hoist Series

## 1.5 to 100 metric ton lifting capacity



### How to order standard equipment

Specify the complete model number as shown. Specify beam size, type and flange width. Note: that 0 (zero) is a number, not a letter in model part numbers.

Example: LCA030DIP3RU3M2A

Series	Power type	Capacity	Range	Body control type	Control type	Suspension	Lift	Control	Options	-E
<b>LC</b>	<b>A</b>	<b>030D</b>	<b>I</b>	<b>P</b>	<b>3</b>	<b>RU</b>	<b>3M</b>	<b>2</b>	<b>A</b>	<b>-E</b>
LC = Liftchain series	A = Air H = Hydraulic (available upon request)	015S = 1.5t single fall 030S = 3t single fall <b>030D</b> = 3t double fall 060S = 6t single fall 060D = 6t double fall 120D = 12t double fall 180T = 18t triple fall 250Q = 25t quadruple fall	I = Industrial M = Mining (available upon request)	P = Pendent C = Pull cord	1 = cord control 2 = 1 motor pendent 3 = 2 motor pendent	3M = 3 m standard XX = Specify length in meters OM = No lift; for flex units <sup>(2)</sup>	2 = 2 m standard XX = Specify length in meters 0 = No control; for flex units <sup>(2)</sup>	A = Standard chain bucket B = Large chain bucket C = Extra large chain bucket K = Cast iron pendent P = Marine paint, 150 μ Q = Offshore paint, 150 μ Z = Sandblast and primer M1 = Per DIN 50049/EN10204 Para 2.2 "Typicals" <sup>(3)</sup> M2 = Per DIN 50049/EN10204 Para 3.1b actual per product as purchased <sup>(3)</sup>	-E = Compliance with the European Machinery Directive (includes overhead and E-Stop as standard)	
			A = fixed lug C = Swivel top hook PU = Plain rigid universal trolley (flat or tapered beam) 1500 to 6000 kg PE = Plain rigid trolley (flat beam) 12000 to 25000 kg PN = Plain rigid trolley (tapered beam) 12000 to 25000 kg GU = Geared rigid universal trolley (flat beam) 1500 to 6000 kg GE = Geared rigid trolley (flat beam) 12000 kg only GN = Geared rigid trolley (tapered beam) 12000 kg only RU <sup>(1)</sup> = Motorized rigid universal trolley (flat or tapered beam) 1500 to 6000 kg RE <sup>(1)</sup> = Motorized rigid trolley (flat beam) 12000 to 25000 kg RN <sup>(1)</sup> = Motorized rigid trolley (tapered beam) 12000 to 25000 kg							

PHS4D-U

Two motor pendent handle

#### Notes:

- Add the letter "A" for articulated trolley (e.g. RUA)
- Flex units are hook mounted hoists with pendent valve chest and pendent handle (P2) or pull cord valve chest and pull cord handle kit (C1) less load chain and control lines. The load chain, control hoses or cords and related hardware are listed below. These models allow us maximum flexibility in meeting customer requirements.

#### Pull cord

Part no.	Description
75790102	Pull cord valve chest
40004-00	Handle kit with warning tag
51777	Nylon cord

#### Pendent

Part no.	Description
PHS2E	2 lever pendent with fittings
PHS4E	4 lever pendent with fittings
50923	Control hose
54798	Strain relief cable 3/32" diameter
DCTK-1	Thimble kit for strain relief cable with warning tag
20417	Quick exhaust valve

#### Bulk chain

Part no.	Description
HCCF005ZP	Zinc plated hand chain

- Lineal length required = lift x (number of falls) + 0.5 meters.  
e.g. For 30 feet of lift on an LCA030DIP:
- 30 feet divided by 3.28 ft/meter = 9.15 meters.
  - LCA030DIP is two falls of LCA1336-G8ZP chain.
  - Lineal length in meters = 9.15 x (2) + 0.5 = 18.8 lineal meters or about 61.7 feet.

- M1** Material traceability certificates according to EN 10204 (Ex DIN 50049) 2.2 on load bearing parts. This conformity document affirms (by the manufacturer) that parts are in compliance with the requirements of the order based on non-specific inspection and testing (i.e. results are typical material properties for these parts).  
**M2** Material traceability certificates according to EN 10204b(Ex DIN 50049) 3.1b on load bearing parts. These documents affirm (by a department independent of the manufacturing department) that the actual parts used in the product are in compliance with the order based on specific inspection and testing (i.e. results are actual material properties for these parts).

- S•COR•E Option R includes the following:**

#### For the hoist:

- Stainless steel pins and fasteners 10 mm and smaller
- 20 μ zinc plated fasteners 11 mm and larger
- Zinc plated top and bottom hook assemblies
- Zinc plated bottom hook sprocket wheel

#### For the trolley:

- Stainless steel pins and fasteners 10 mm and smaller
- 20 μ zinc plated fasteners 11 mm and larger
- Solid bronze wheels
- Rubber bumpers

- S•COR•E Option T includes the following:**

#### For the hoist:

- Stainless steel pins and fasteners 10 mm and smaller
- 20 μ zinc plated fasteners 11 mm and larger
- Cast iron pendent
- Bronze coated central part, driving sprocket wheels, chain release arm
- Bronze coated top and bottom hook assemblies
- Bronze coated bottom hook sprocket wheel

#### For the trolley:

- Stainless steel pins and fasteners 10 mm and smaller
- 20 μ zinc plated fasteners 11 mm and larger
- Cast iron pendent
- Solid bronze wheels
- Rubber bumpers

# Hercu-Link™ Electric Chain Hoist

## 5 to 50 metric ton capacity



### Standard features

- Space saving, low headroom, compact design; approximately one third the “envelope” size of comparable wire rope hoists
- True vertical lift
- Continuous duty hoist and trolley motor
- IEEE45 marine grade motors
- Thermal overload protection
- 110 volt control circuit with fused and grounded transformer
- Class ‘F’ insulation on hoist motor
- All popular voltages available; 460-3-60 standard
- Upper and lower limit switches
- NEMA 4 weather resistant control enclosure
- 16mm and 22mm alloy zinc plated load chain. Heat treated and calibrated, 10ft (3 m) of lift standard
- Chain guides
- Alloy steel hooks with safety latches and roller thrust bearings
- Planetary gearing
- Lifting lugs for easy installation
- Automatic multiple disc motor brake
- Manual brake release (for lowering load in event of power loss)
- Trolley rail sweeps (safety lugs)
- Trolley guide rollers are standard on Frame 2 motorized trolley models
- All non-oil bath bearings are regreasable



HE1-020M motorized trolley mount

### Options:

- Dual speed motors
- 208, 230, 380, 400, 415, 575 motor voltages
- Longer lifts
- Longer pushbutton cord
- Longer power supply cables
- Galvanized expanded metal chain containers
- Plain, geared, motorized trolley units
- Corrosion resistant marine grade coating system: sandblast to white metal finish and carbozinc primer with a Marine 812 finish
- Trolley bumpers and guide rollers (standard on Frame 2 models)
- Sandblast carbozinc primer
- Electronic overload protection

### Hercu-Link specifications

Model no.	Capacity		Head room		Hoist lift speed/min		Hoist lower speed/min		Hoist hp	Chain falls	Trolley speed		Trolley hp	no. of wheels	Wheel loading per wheel		Ship weight	
	lbs	kg	in.	mm	ft	m	ft	m			ft/min	m/min			lbs	kg	lbs	kg
<b>Frame 1 (16 mm chain)</b>																		
HE1-005H	11000	5000	34.44	875	17	5.2	19.1	5.8	7.5	1	–	–	–	–	–	–	685	311
HE1-005M	11000	5000	30.50	775	17	5.2	19.1	5.8	7.5	1	18	5.5	1.5	4	2968	1349	905	411
HE1-010H	22000	10000	41.81	1062	8.5	2.6	9.6	2.9	7.5	2	–	–	–	–	–	–	765	348
HE1-010M	22000	10000	36.94	938	8.5	2.6	9.6	2.9	7.5	2	18	5.5	1.5	4	5755	2616	1105	502
HE1-015H	33000	15000	48.13	1222	5.6	1.7	6.3	1.9	7.5	3	–	–	–	–	–	–	875	398
HE1-015M	33000	15000	41.63	1057	5.6	1.7	6.3	1.9	7.5	3	18	5.5	1.5	4	8558	3890	1315	598
HE1-020H	44000	20000	49.50	1257	4.3	1.3	4.8	1.5	7.5	4	–	–	–	–	–	–	975	443
HE1-020M	44000	20000	41.44	1053	4.3	1.3	4.8	1.5	7.5	4	18	5.5	1.5	4	11332	5151	1425	648
<b>Frame 2 (22 mm chain)</b>																		
HE2-012H	26400	12000	43.88	1114	15	4.6	16	4.9	15	1	–	–	–	–	–	–	965	439
HE2-012M	26400	12000	41.13	1045	15	4.6	16	4.9	15	1	18	5.5	1.5	4	7209	3277	1415	643
HE2-025H	55000	25000	56.50	1435	7.5	2.3	8	2.4	15	2	–	–	–	–	–	–	1235	561
HE2-025M	55000	25000	47.44	1205	7.5	2.3	8	2.4	15	2	18	5.5	1.5	8	14135	6425	1835	834
HE2-037H	81400	37000	71.88	1826	5	1.5	5.5	1.7	15	3	–	–	–	–	–	–	2230	1014
HE2-037M	81400	37000	54.19	1376	5	1.5	5.5	1.7	15	3	18	5.5	1.5	8	10751	4887	3700	1682
HE2-050H	110000	50000	80.44	2043	3.7	1.1	4.3	1.3	15	4	–	–	–	–	–	–	2995	1361
HE2-050M	110000	50000	58.25	1480	3.7	1.1	4.3	1.3	15	4	18	5.5	1.5	8	14304	6502	4665	2120

# Hercu-Link™ Electric Chain Hoist

## 5 to 50 metric ton capacity



### Dimensions: hook mounted hoist

Frame 1	A		B		B <sup>1</sup>		C		F		G		H	
	in.	mm	in.	mm	in.	mm	in.	mm	in.	mm	in.	mm	in.	mm
HE1-005H	34.44	875	13.00	330	21.75	552	25.44	646	1.81	46	22.75	578	21.50	546
HE1-010H	41.81	1062	13.00	330	21.75	552	25.44	646	2.63	67	22.75	578	21.50	546
HE1-015H	48.13	1222	13.00	330	27.94	710	31.44	799	3.00	76	22.75	578	21.50	546
HE1-020H	49.50	1257	13.63	346	22.25	565	25.44	646	3.63	92	25 1/4	641	23.50	597
	J		K		L		M		N		P		Y	
HE1-005H	37.00	940	9.50	241	10.50	267	3.50	89	3.50	89	1.88	48	6.50	165
HE1-010H	45.81	1167	9.50	241	10.50	267	6.00	152	8.50	216	2.50	64	8.69	221
HE1-015H	53.63	1362	9.50	241	10.50	267	5.25	133	10.00	254	3.38	86	11.00	279
HE1-020H	55.50	1409	9.50	241	10.50	267	9.38	238	8.50	216	4.00	102	13.63	346
Frame 2	A		B		B <sup>1</sup>		C		F		G		H	
	in.	mm	in.	mm	in.	mm	in.	mm	in.	mm	in.	mm	in.	mm
HE2-012H	43.00	1092	19.63	498	28.75	730	33.00	838	2.63	67	28.13	714	21.00	533
HE2-025H	58.63	1489	19.63	498	28.75	730	33.00	838	3.63	92	28.13	714	21.00	533
HE2-037H	71.88	1826	20.75	527	28.75	730	33.00	838	5.06	129	31.13	791	24.00	610
HE2-050H	80.44	2043	20.75	527	28.75	730	33.00	838	6.69	170	31.13	791	24.00	610
	J		K		L		M		N		P		Y	
HE2-012H	48.13	1222	9.69	246	10.88	276	4.50	114	4.50	114	2.25	57	8.69	221
HE2-025H	66.00	1676	9.69	246	10.88	276	6.88	175	11.13	286	3.25	83	13.63	346
HE2-037H	82.00	2083	9.69	246	10.88	276	11.13	283	11.13	286	4.25	108	15.44	392
HE2-050H	93.81	2383	9.69	246	10.88	276	12.63	321	11.13	286	6.50	165	20.63	524

Frame 1 uses 16 mm chain; frame 2 uses 22 mm chain.

Chain bucket includes trailing trolley on HE1-015M and any other 4 wheel trolley model with 35 feet (10.7 m) of lift or more.

### Hook mounted hoist

Frame 1: HE1-005H, HE1-010H,  
HE1-015H, HE1-020H

Frame 2: HE2-012H, HE2-025H,  
HE2-037H, HE2-050H

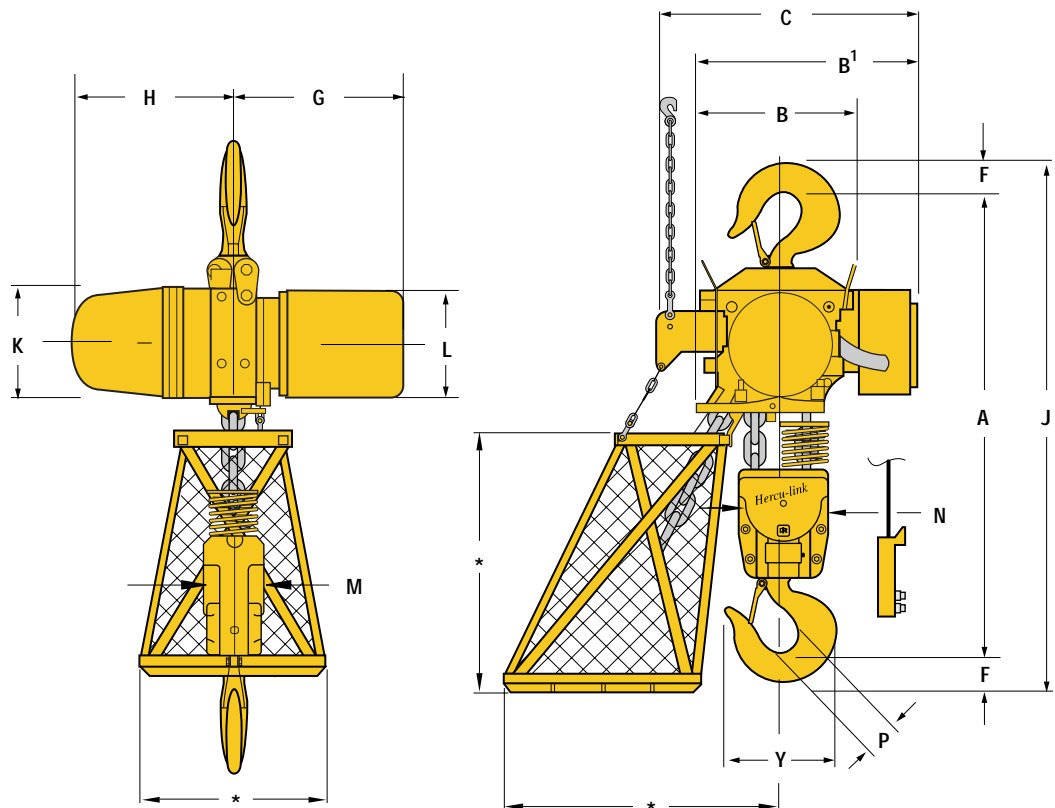

Dimensions are subject to change. Contact factory for certified prints

# Hercu-Link™ Electric Chain Hoist

5 to 50 metric ton capacity



## Dimensions: trolley mounted hoist; frame 1 with 16 mm chain

Frame 1	A		B		C		D		E		F		G		H	
	in.	mm	in.	mm	in.	mm	in.	mm	in.	mm	in.	mm	in.	mm	in.	mm
HE1-005M	30.50	775	27.31	694	3.88	98	—	—	7.75	197	1.81	46	22.75	578	21.50	546
HE1-010M	36.94	938	27.31	694	3.88	98	—	—	7.75	197	2.59	66	22.75	578	21.50	546
HE1-015M	41.63	1051	30.56	776	4.50	114	—	—	9.00	229	3.00	76	22.75	578	21.50	546
HE1-020M	41.44	1053	32.00	813	5.88	149	—	—	11.75	298	3.63	92	25.25	641	23.50	597
	J		K		L		M		N		O		P		Q	
HE1-005M	41.44	1064	9.50	241	10.50	267	3.50	89	3.50	89	10.06	256	1.88	48	6.13	156
HE1-010M	49.63	1260	9.50	241	10.50	267	6.00	152	8.50	216	10.06	256	2.50	64	6.13	156
HE1-015M	56.63	1387	9.50	241	10.50	267	5.25	133	10.00	254	10.75	273	3.38	86	6.88	175
HE1-020M	56.06	1424	9.50	241	10.50	267	9.44	240	8.50	216	12.19	310	4.00	102	9.00	229
	R		S		T		W		X		Y		Z			
HE1-005M	7.25	184	2.63	67	1.94	49	19.81	503	5.00	127	6.50	165	—	—		
HE1-010M	7.25	184	2.63	67	1.94	49	19.81	503	5.00	127	8.69	221	—	—		
HE1-015M	8.63	219	3.25	83	2.56	65	20.00	508	8.88	225	11.00	279	—	—		
HE1-020M	11.38	289	3.06	78	2 3/16	56	19.50	495	6.00	152	13.63	346	—	—		

**Important:**  
It is the user's responsibility to specify proper beam size for the maximum wheel loading. Consult w/a qualified engineer.

Chain bucket includes trailing trolley on HE1-015M and any other 4 wheel trolley model with 35 feet (10.7 m) of lift or more.

**4-wheel motorized trolley**  
**Frame 1:** HE1-005M, HE1-010M, HE1-015M, HE1-020M  
**Frame 2:** HE2-012M  
 (see Frame 2 dimensions on following page)

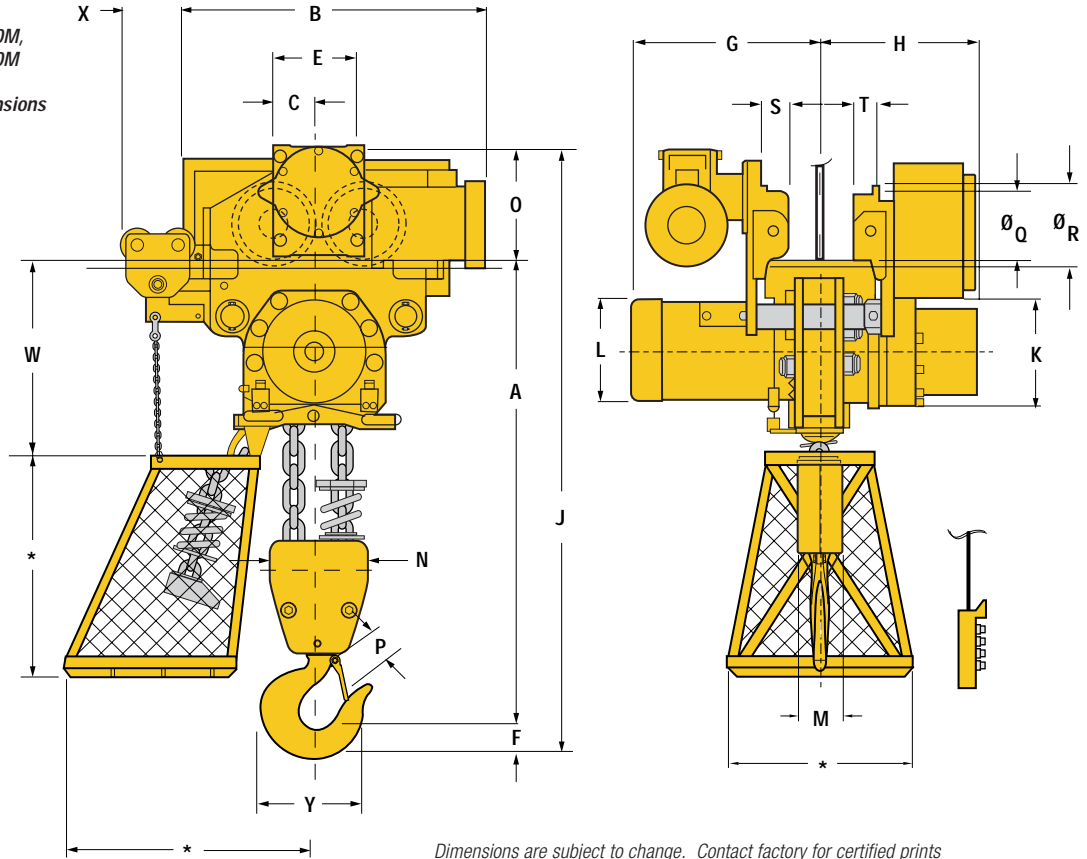

Dimensions are subject to change. Contact factory for certified prints



# Hercu-Link™ Electric Chain Hoist

## 5 to 50 metric ton capacity



### Dimensions: trolley mounted hoist with 22 mm chain

Frame 2	A		B		C		D		E		F		G		H	
	in.	mm	in.	mm	in.	mm	in.	mm	in.	mm	in.	mm	in.	mm	in.	mm
HE2-012M	41.13	1045	32.81	833	4.50	114	—	—	9.00	229	2.56	65	28.13	714	21.00	533
HE2-025M	47.44	1205	62.13	1578	19.00	483	24.50	622	9.00	229	3.63	92	28.13	714	21.00	533
HE2-037M	54.19	1376	64.88	1648	24.00	610	26.50	673	11.75	298	5.06	129	31.13	791	24.00	610
HE2-050M	58.25	1480	64.88	1648	24.00	610	26.50	673	11.75	298	6.69	170	31.13	791	24.00	610
	J		K		L		M		N		O		P		Q	
HE2-012M	54.50	1384	9.69	246	10.88	276	4.50	114	4.50	114	10.75	273	2.25	57	6.88	175
HE2-025M	62.81	1595	9.69	246	10.88	276	6.88	175	11.25	286	11.56	294	4.00	102	6.88	175
HE2-037M	72.25	1835	9.69	246	10.88	276	11 1/8	283	11.25	286	13.00	330	4.75	121	9.00	229
HE2-050M	77.94	1980	9.69	246	10.88	276	12.63	321	11.25	286	13.00	330	6.50	165	9.00	229
	R		S		T		W		X		Y		Z			
HE2-012M	8.63	219	3.25	83	2.56	65	24.44	621	8.88	225	8.69	221	—	—		
HE2-025M	8.63	219	3.19	81	2.56	65	18.50	470	—	—	13.63	346	21.50	546		
HE2-037M	11.38	289	3.19	81	2.25	57	19.19	487	—	—	15.44	392	24.50	622		
HE2-050M	11.38	289	3.19	81	2.25	57	19.19	487	—	—	20.63	524	24.50	622		

**Important:**  
It is the user's responsibility to specify proper beam size for the maximum wheel loading. Consult w/a qualified engineer.

8-wheel  
motorized trolley  
Frame 2:  
(HE2-025M,  
HE2-037M,  
HE2-050M)

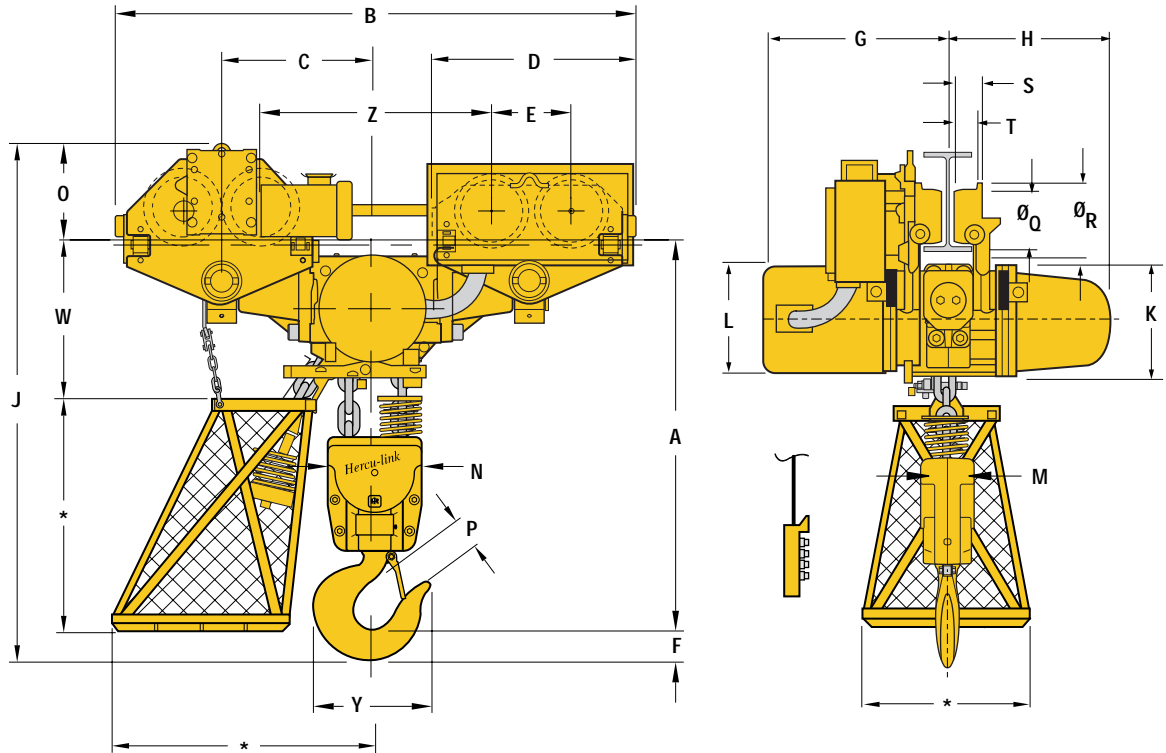

Dimensions are subject to change. Contact factory for certified prints

# Hercu-Link™ Electric Chain Hoist

## 5 to 50 metric ton capacity



### How to Order:

Specify the complete model as shown. Specify beam size, type and flange width. **Example: HE1-005MA3-30-27-4P**

Series	Frame size	Capacity	Suspension	Trolley flange adj.	Control	Lift	Control drop	Voltage	Options																											
<b>HE</b>	<b>1</b>	<b>- 005</b>	<b>M</b>	<b>A</b>	<b>3</b>	<b>- 30 -</b>	<b>27</b>	<b>4</b>	<b>P</b>																											
<p><b>H</b> = Hercu-Link series</p> <p><b>A</b> = Electrically powered</p> <p>Note: See Air Hercu-Link section for air and hydraulic models.</p>			<p><b>H</b> = Top hook mount</p> <p><b>C</b> = Clevis mount<sup>(1)</sup></p> <p><b>D</b> = Deck mount<sup>(1)</sup></p> <p><b>P</b> = Plain trolley</p> <p><b>G</b> = Geared trolley</p> <p><b>M</b> = Electric motor trolley</p>			<p><b>XX</b> = Length of lift</p> <p><b>XX</b> = Control drop pendent (6 ft/2m standard)</p>		<p>1 = 208-3-60</p> <p>2 = 230-3-60</p> <p>3 = 380-3-50</p> <p><b>4</b> = 460-3-60</p> <p>5 = 575-3-60</p> <p>6 = 415-3-50</p> <p>7 = 400-3-50</p>																												
<table border="0"> <tr> <td></td> <td>tons</td> <td>lbs.</td> </tr> <tr> <td><b>1</b></td> <td><b>005</b></td> <td>= 5 = 11,000</td> </tr> <tr> <td></td> <td>010</td> <td>= 10 = 22,000</td> </tr> <tr> <td></td> <td>015</td> <td>= 15 = 33,000</td> </tr> <tr> <td></td> <td>020</td> <td>= 20 = 44,000</td> </tr> <tr> <td><b>2</b></td> <td>012</td> <td>= 12.5 = 27,500</td> </tr> <tr> <td></td> <td>025</td> <td>= 25 = 55,000</td> </tr> <tr> <td></td> <td>037</td> <td>= 37.5 = 82,500</td> </tr> <tr> <td></td> <td>050</td> <td>= 50 = 110,000</td> </tr> </table>				tons	lbs.	<b>1</b>	<b>005</b>	= 5 = 11,000		010	= 10 = 22,000		015	= 15 = 33,000		020	= 20 = 44,000	<b>2</b>	012	= 12.5 = 27,500		025	= 25 = 55,000		037	= 37.5 = 82,500		050	= 50 = 110,000	<p><b>A</b> = Standard</p> <p><b>B</b> = 2" (50.8 mm) extension</p> <p><b>C</b> = 4" (101.6 mm) extension</p> <p><b>D</b> = 6" (152.4 mm) extension</p> <p><b>M</b> = No trolley; used with hook, clevis and deck mount</p>			<p>2 = 1 motor pendent (2 button)</p> <p><b>3</b> = 2 motor pendent (4 button)</p> <p>4 = 3 motor pendent (6 button)</p> <p>5 = 1 motor pendent with mainline disconnect</p> <p>6 = 2 motor pendent with mainline disconnect</p> <p>7 = 3 motor pendent with mainline disconnect</p>		<p><b>Hoist</b></p> <p><b>D</b> = Dual speed</p> <p><b>L</b> = Electronic overload protection</p> <p><b>P</b> = Marine 812 finish</p> <p><b>Q</b> = Special paint; specify</p> <p><b>T</b> = Galvanized chain container</p> <p><b>Y</b> = Hull bumpers</p> <p><b>Z</b> = Sandblast &amp; carbozinc primer</p>	
	tons	lbs.																																		
<b>1</b>	<b>005</b>	= 5 = 11,000																																		
	010	= 10 = 22,000																																		
	015	= 15 = 33,000																																		
	020	= 20 = 44,000																																		
<b>2</b>	012	= 12.5 = 27,500																																		
	025	= 25 = 55,000																																		
	037	= 37.5 = 82,500																																		
	050	= 50 = 110,000																																		
						<p><b>Trolley</b></p> <p><b>B</b> = Trolley bumpers<sup>(2)</sup></p> <p><b>G</b> = Trolley guide rollers<sup>(2)</sup></p> <p><b>K</b> = Clevis in lieu of bottom hook<sup>(1)</sup></p> <p><b>R</b> = Copper plated S•COR•E pkg (see description below)</p> <p><b>S</b> = Solid bronze S•COR•E pkg (see description below)</p>																														

(1) P.O.A. Contact Technical Sales.  
 (2) Standard on Frame 2 models

#### ■ S•COR•E (Option codes R and S)

- R** = The product will be equipped with zinc plated load chain, copper plated load hook(s) and trolley wheels. Zinc plated hand chain if applicable.
- S** = Up to 20 ton units will be equipped with zinc plated load chain, solid bronze load hook(s) and trolley wheels. Zinc plated hand chain if applicable.

# Trolleys and Accessories

Over 70 years of experience in the Material Handling Industry is reflected in IR's plain, brake and piston motor driven trolleys.

Whether performing routine maintenance tasks or a complete bridge retrofit, IR trolleys and our new Man Rider™ rated trolleys keep your project rolling.



**NEW!**

# Trolleys

Man Rider™, Plain and Brake



These 3 and 6 metric ton trolleys are designed specifically for the bridge retrofit and new construction market. These rugged and durable manual trolleys are offered with both utility and Man Rider ratings to fit a variety of bridge and scaffolding applications.

**Standard features**

- Incredibly tough, long-lasting cast iron wheels are through hardened for wear resistance. Tapered tread wheels are standard.
- Rail sweeps (safety lugs) standard.
- Axles and bearings have grease fittings for maximum life and corrosion resistance.
- Air activated “parking brake” on BT/M2-3 and 6 models.



BTP Trolley



BTM Trolley

**Options**

- Flat tread wheels
- Special paint coatings
- Suspension shafts to fit a variety of beam types and widths

**Specifications: BT/M2-3, BT/M2-6 and BTP-MR3/6 series**

Base model	Utility load lbs (kg)	Design factor at utility load	Man-Rider load lbs (kg)	Design factor at M-R load	Flange adjustment in. (mm)	Inlet hose in.	Operating pressure psig (bar)	Parking brake (PB)		Min. beam curve radius in. (mm)		
								Type	Material		Horiz. hold cap.	min. hold-off pressure
BT/M2-3	6600 (3000)	5:1	3300 (1500)	10:1	3.80 – 4.20 (97–107)	1/4	85–125 (6–8.75)	Air release/spring set	non-asbestos	600 lbs (273 kg)	70 psig (4.9 bar)	48 (1219)
BT/M2-6	13200 (6000)	5:1	6600 (3000)	10:1	4.00–5.00 (102–127)	1/4	85–125 (6–8.75)	Air release/spring set	non-asbestos	600 lbs (273 kg)	70 psig (4.9 bar)	60 (1524)
BTP-MR3/6	13200 (6000)	5:1	6600 (3000)	10:1	4.00–5.00 (102–127)	na	na	na	na	na	na	60 (1524)

**Dimensions**

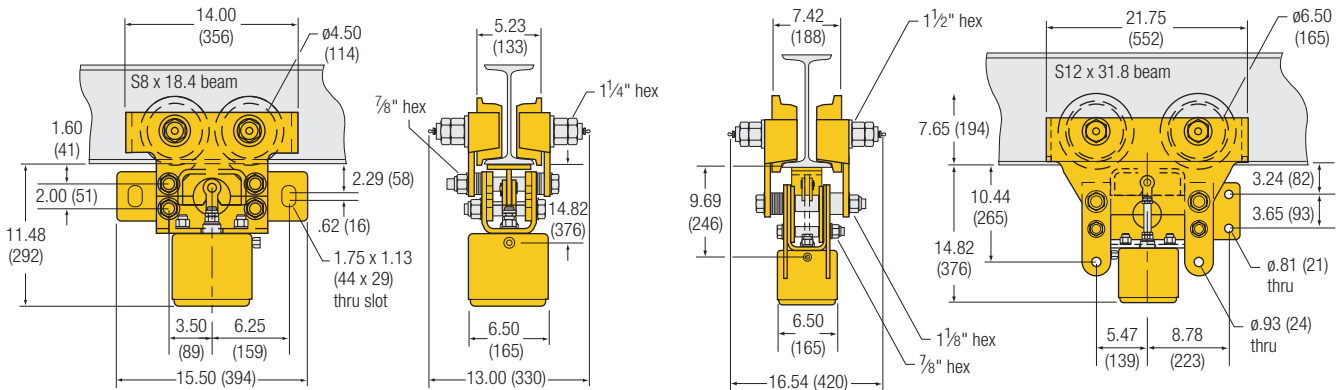

BT/M2-3

BT/M2-6

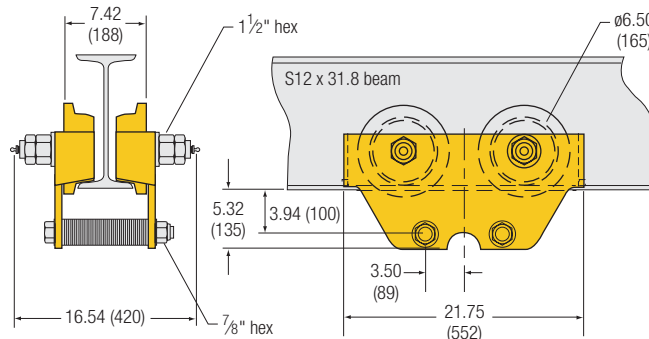

BTP/M3-6

Dimensions are subject to change. Contact factory for certified prints

**NEW!**

# Trolleys

Man Rider™, Piston Motor Driven and 4-wheel drive



■ **ATC and ATE features and benefits:**

- Reintroduced by popular demand
- **Available with Man Rider™ rating** for scaffolds per ANSI / ASME B30.23.
- Reversible radial piston motor allows unmatched speed and load control.
- Drop forged connecting rods and crank pins add to the legendary IR durability.
- 4 wheel drive provides maximum traction and pulling power.
- Pendant control valve chest with proportional flow "live air" for precision control.
- Incredibly tough, long-lasting cast iron or steel wheels are through hardened. Tapered or flat tread available.
- Ductile iron side plates
- Rail sweeps (safety lugs) standard.
- Axles and bearings have grease fittings for maximum life and corrosion protection.



ATC Trolley

**Specifications: ATC and ATE series @ 90 psi (6.3 bar)**

Base model	Capacity metric tons	Control type	Tractive force lbs (kg)	Trolley speed @ loads in metric tons fpm (m/min)							Min. turn radius ft (mm)	Avg air consump cfm (m3/min)	Ship weight lbs (kg)
				1/4	1/2	1	2	3	5	6			
ATC	.25 – 3	Pendent	450 (205)	180 (55)	180 (55)	180 (55)	160 (49)	140 (43)	–	–	6 (1829)	63 (1.8)	245 (111)
ATC-MR15/3	1.5 Man Rider 3.0 Utility	Pendent	450 (205)	180 (55)	180 (55)	180 (55)	160 (49)	140 (43)	–	–	6 (1829)	63 (1.8)	245 (111)
ATE	4.5 – 6	Pendent	600 (273)	–	–	139 (42)	123 (38)	107 (33)	75 (23)	60 (18)	6 (1829)	63 (1.8)	254 (115)
ATE-MR3/6	3 Man Rider 6 Utility	Pendent	600 (273)	–	–	139 (42)	123 (38)	107 (33)	75 (23)	60 (18)	6 (1829)	63 (1.8)	254 (115)

**Dimensions**

Hoist capacity metric tons	Fits beam flange width in. (mm)	A in. (mm)	B in. (mm)	C in. (mm)	D in. (mm)	E in. (mm)	F in. (mm)	G in. (mm)	H in. (mm)	J in. (mm)	K in. (mm)	L in. (mm)
.25 – 3	3.25 – 7.25 (83 – 184)	4.56 (116)	4.75 (121)	10.25 (260)	16.13 (410)	4.88 (124)	1.63 (41)	8.5 (216)	9.06 (230)	7 (178)	4.75 (121)	0.88 (22)
4.5 – 6	3.25 – 7.25 (83 – 184)	4.63 (111)	6.25 (159)	13 (330)	16.38 (416)	5.19 (132)	1.5 (38)	9 (229)	10.13 (257)	8.13 (206)	7 (178)	1.13 (29)

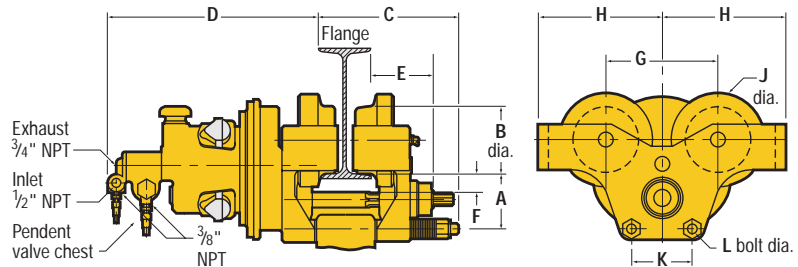
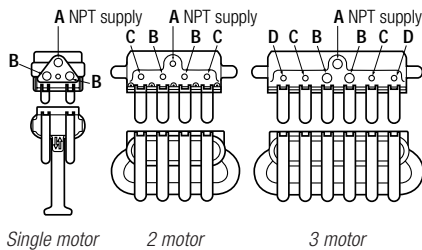

**Pendent handles**

Type	Part no.	Dimensions (in.) (NPT air inlet)			
		A	B	C	D
Single motor	MR-269C	3/8	3/8	-	-
Two motor	MR-A122C	3/8	3/8	-	-
	C6H20A-A122B	1/2	1/2	3/8	-
Three motor	MR-A132C	3/8	3/8	3/8	3/8
	C6H20A-A132B	1/2	1/2	3/8	3/8

Choose the 2 or 3 motor pendent handle based on the air consumption requirements of the machine(s) being run.

**Approximate air flow**

NPT air inlet	scfm	m³/min
3/8 inch	100	2.83
1/2 inch	200	5.66

**How to Order:**

Dimensions are subject to change. Contact factory for certified prints

Specify trolley by complete model number as illustrated. This model includes: Base model, Wheel type, Manrider rating, Control, Control length, and Options. **Example:** ATC-MR15/3-210B = 1/4 - 3 ton trolley with tapered wheels, 3 ton utility and 1.5 ton Manrider rating, one motor pendent, 10 ft of control length and bumpers.

Base model	Wheel	Manrider	Controls	Control length	Options
ATC	-	MR15/3	2	10	B
ATC = 1/4 - 3 ton	-	Utility model std. (no option code req'd). Insert model code below for Man Rider option	0 = No pendent 2 = MR-K269C (std 1 mtr) 3 = C6H20A-A169B (1 mtr) 4 = MR-A122C (2 mtr) 5 = C6H20A-A122B (2 mtr) 6 = MR-A132C (3 mtr) 7 = C6H20A-A132B (3 mtr)	XX = Control drop; specify length in feet. 7 feet (2.1 m) is std.	B = Bumpers H = Hook-on adapter Q = Special paint; please specify P = Marine 812 finish Z = Sandblast and carbozinc primer
ATE = 4 1/2 - 6 ton	-	MR15/3: Utility rating, 3 ton; Man Rider, 1.5 ton MR3/6: Utility rating, 6 ton; Man Rider, 3 ton			
- = Tapered T = Flat tread					

**NEW**

## Accessories Winch Construction Cages



**IR's construction cages make using, moving, storing, and protecting IR air winches easier than ever. Designed to meet ANSI/ASME 5:1 structural design codes for lifting, they are a welcome relief from the liability risk of homemade units.**

■ **Construction cages are:**

- Made by certified welders from either 2 ½ by ¼ or 3 by ⅜ inch steel bar for maximum protection.
- Their own perfect shipping containers. No wooden skids or pallets required.
- Designed with generously sized cutouts in the base for easy fork lift access.
- Standard with welded pins in the uprights so they can be stacked up to three high, saving valuable floor or yard space.
- Mounted on a steel base that allows easy bolting or welding to the deck.
- Equipped with lifting eyes to allow a balanced two point pick from overhead. The lifting eyes accept large hooks and are designed to handle the cage and the winch with a full drum of wire rope.
- Wide open in the front for cable take off from the winch at an angle.
- Hot dip galvanized for maximum protection from corrosion.

**How to Order:**

**Examples:** order *BU7AE* or *FA5A-LMX1E* for a winch in the cage, or order *CC -BU7A* or *CC -FA5A-LMX1* for the cage only. Custom inquiries welcome. Please send a dimensional drawing of the winch to our engineering department.



FA2B-RMX1HE



FA5A-LMX1HE



FA7-24XK1E



BU7A-E



FA10-40XK1E

**Setting new standards in pneumatic control systems.**

■ **Standard features:**

- Fully enclosed impact resistant frame
- Watertight enclosure with corrosion proof features suitable for offshore, petrochemical and other severe environments
- No working parts exposed to the atmosphere
- Integral dump valves bleed excess air to eliminate “control lag”
- Color coded air hose for functional identification
- Pinpoint spotting for exceptional load control
- Readily adaptable for IR Hercu-Links and Force-5 air winches
- May be installed on any pilot air operated crane control system
- Safety guards around push buttons help eliminate accidental control actuation
- Up to three functions (six motions)

■ **Options**

- Longer lengths of control hose in 10 foot (3 m) sections
- Two, four and six button models
- Additional dump valves
- Emergency stop/start control

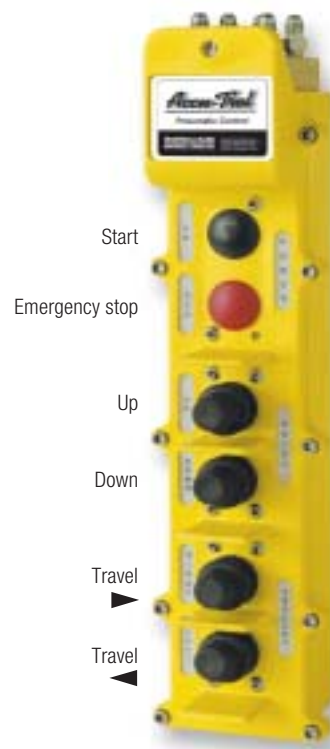

A2-4Y Accu-Trol, 4 button with ON-OFF

**Specifications**

Model	Configuration	Pressure range psi (bar)		Port dia. NPT
A1-4N	2 button only	50 – 125	(3.5 – 8.75)	1/8 inch (3 mm)
A2-4N	4 button only	50 – 125	(3.5 – 8.75)	1/8 inch (3 mm)
A2-4Y	4 button with ON - OFF	50 – 125	(3.5 – 8.75)	1/8 inch (3 mm)
A3-6N	6 button only	50 – 125	(3.5 – 8.75)	1/8 inch (3 mm)
A3-6Y	6 button with ON - OFF	50 – 125	(3.5 – 8.75)	1/8 inch (3 mm)

**How to Order:**

Accu-Trol model code: Accu-Trol (A) with three (3) functions, six (6) buttons, emergency shut-off and 30 feet of pendent hose. **Example: A3-6Y30**

Accu-Trol hose manifold	Pushbutton kits	-	Common parts	On/off emergency cut-off switch	Hose kit (length of pendent drop) <sup>1</sup>
A	3	-	6	Y	30
A = Accu-Trol	1 = 1 kit (hoist) 2 = 2 kits (hoist and trolley) 3 = 3 kits (hoist, trolley and bridge)	-	4 = 2 or 4 button pendent box 6 = 6 button pendent box	N = No, not included Y = Yes, included	0 = 0 (use to specify pendent handle only; e.g. A1-4N0) 10 = 10 feet/3 meters 20 = 20 feet/6 meters 30 = 30 feet/9 meters 40 = 40 feet/12 meters 50 = 50 feet/15.25 meters xx = Specify length

**Hose bundle assembly with strain relief**

(Used on series: Palair Plus, Palair CP, Accu-Trol, FA, Liftstar, Hercu-Link, ULA)

Length		without Emergency Stop			with Emergency Stop		
ft	m	2 button Part no.	4 button Part no.	6 button Part no.	2 button Part no.	4 button Part no.	6 button Part no.
10	3.0	21653-15	21654-15	21655-15	21656-15	21657-15	21658-15
15	4.5	21653-15	21654-15	21655-15	21656-15	21657-15	21658-15
20	6.0	21653-20	21654-20	21655-20	21656-20	21657-20	21658-20
25	7.6	21653-25	21654-25	21655-25	21656-25	21657-25	21658-25
30	9.0	21653-30	21654-30	21655-30	21656-30	21657-30	21658-30
35	10.7	21653-35	21654-35	21655-35	21656-35	21657-35	21658-35
40	12.0	21653-40	21654-40	21655-40	21656-40	21657-40	21658-40
45	13.7	21653-45	21654-45	21655-45	21656-45	21657-45	21658-45
50	15.25	21653-50	21654-50	21655-50	21656-50	21657-50	21658-50

1. 1/4 inch (6 mm) hose with working pressure of 250 psi (17.5 bar)  
 2. Dump valves included on lengths of 10 feet (3 meters) and longer to provide quick exhaust and improve control response.  
 3. For hose bundle lengths over 50 feet (15.25 meters) contact Technical Support for control acceptability.

## Accessories

### Electric-Over-Air Pendent Control System



***This updated remote control allows unlimited distance between the operator and winch or hoist without the excessive pressure drops, quick exhaust valves and resultant delays found in air control lines. On pendent controls, dialing-in an electrical setting determines the speed. Push buttons provide pay-in or pay-out. For variable speed control, the control buttons are depressed and the dial-in knob provides proportional control. The joystick lever control provides traditional winch style variable speed in a hand held or wall mounted control box.***

#### ■ Standard Features

- Portable, easy to hold control pendent
- NEMA 4 control box and pendent
- Holding down the control button and turning the Dial-In control provides variable speed
- Automatic return-to-center when joystick is released
- Emergency stop button on control enclosure
- Unlimited control length
- Requires pilot control valve chest for field retrofit
- Adaptable to most winch models and Hercu-Link hoists

#### ■ Product availability

The Electric Over Air remote control system is available for all Hercu-Link air hoists and Force 5 air winches. Contact Technical Sales for information regarding suitability with other air powered products or for spark and corrosion resistant or explosion proof applications. The overspeed indicator is currently available as an option only on FA2MRA, FA2.5MRA and FA5MRA.

#### How to Order

To order with a complete unit, use appropriate control option in that unit's model driver, and specify control type (pendent **P** or lever **L**).

To order separately, specify complete model number as shown. This model code includes: Series, Control type, Control length, and Options. **Example: E/A-PCS20L**

Series	Control type	Control length	Options
<b>E/A</b>	<b>PCS</b>	<b>20</b>	<b>L</b>
<b>E/A</b> = Electric-Over-Air	<b>LCS</b> = Lever control <b>PCS</b> = Pendent control	<b>20</b> = 20 feet standard <b>XX</b> = Specify length in feet	<b>L</b> = Overspeed indicator

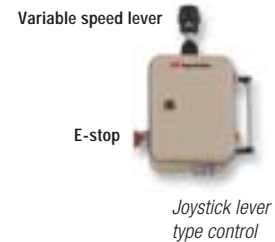



**Air line accessories**

Model	Air inlet size	FRL size	Filter	Regulator	Lubricator	FRL combo	Liquidator	Strainer	Muffler / NPT size <sup>(1)</sup>
BU7A	0.5 NPT	0.75 NPT	F30-06-000	R28-06-F0G0-28	L30-06-000	C31-06-G00	8846-W1-090	EU-A267	52104 / .75
FA150KGMR	0.5 NPT	0.75 NPT	F30-06-000	R28-06-F0G0-28	L30-06-000	C31-06-G00	8846-W1-090	EU-A267	52104 / .75
EU/EUL	0.75 NPT	1.0 NPT	F30-08-000	R38-08-F0G0-28	L30-08-000	C31-08-G00	8848-W1-150	HU-A267AT	50592 / 1.0
FA2 <sup>(2)</sup>	1.25 NPT	1.5 NPT	F35-0B-C28	R40-0B-G00	L40-0B-G00	–	8834-W1-000	HU-A267AT	52465 / 1.25
FA2B <sup>(2)</sup>	1.25 NPT	1.5 NPT	F35-0B-C28	R40-0B-G00	L40-0B-G00	–	8834-W1-000	K4U-A267AT	50592 / 1.0
HU40A	1.25 NPT	1.5 NPT	F35-0B-C28	R40-0B-G00	L40-0B-G00	–	8834-W1-000	K4U-A267AT	50592 / 1.0
FA2.5 <sup>(2)</sup>	1.25 NPT	1.5 NPT	F35-0B-C28	R40-0B-G00	L40-0B-G00	–	8834-W1-000	K4U-A267AT	50594 / 2.0
FA2.5A <sup>(2)</sup>	1.25 NPT	1.5 NPT	F35-0B-C28	R40-0B-G00	L40-0B-G00	–	8834-W1-000	–	50594 / 2.0
FA5 <sup>(2)</sup>	1.25 NPT	1.5 NPT	F35-0B-C28	R40-0B-G00	L40-0B-G00	–	8834-W1-000	K4U-A267AT	50594 / 2.0
FA5A <sup>(2)</sup>	1.25 NPT	1.5 NPT	F35-0B-C28	R40-0B-G00	L40-0B-G00	–	8834-W1-000	–	50594 / 2.0
FA7 <sup>(2)</sup>	1.25 NPT	1.5 NPT	F35-0B-C28	R40-0B-G00	L40-0B-G00	–	8834-W1-000	K4U-A267AT	50594 / 2.0
FA10 <sup>(2)</sup>	1.25 NPT	1.5 NPT	F35-0B-C28	R40-0B-G00	L40-0B-G00	–	8834-W1-000	K4U-A267AT	50594 / 2.0
LS150R	0.5 BSP	0.75 NPT	F30-06-000	R30-06-000	L30-06-000	C31-06-G00	8846-W1-090	EU-A267	Built-in, internal muffling system
LS300R	0.5 BSP	0.75 NPT	F30-06-000	R30-06-000	L30-06-000	C31-06-G00	8846-W1-090	EU-A267	
LS600R	0.5 BSP	0.75 NPT	F30-06-000	R30-06-000	L30-06-000	C31-06-G00	8846-W1-090	EU-A267	
LS1500R	0.75 BSP	1.0 NPT	F30-08-000	R30-08-000	L30-08-000	C31-08-G00	8848-W1-150	EU-A267	
LS2000R	1.25 BSP	1.5 NPT	F35-0B-C28	R40-0B-G00	L40-0B-G00	–	8834-W1-000	K4U-A267AT	
LS5000R	1.25 BSP	1.5 NPT	F35-0B-C28	R40-0B-G00	L40-0B-G00	–	8834-W1-000	K4U-A267AT	
PS1000R	0.5 BSP	0.75 NPT	F30-06-000	R30-06-000	L30-06-000	C31-06-G00	8846-W1-090	EU-A267	
PS2400R	0.75 BSP	1.0 NPT	F30-08-000	R30-08-000	L30-08-000	C31-08-G00	8848-W1-150	EU-A267	
PS4000R	1.25 NPT	1.5 NPT	F35-0B-C28	R40-0B-G00	L40-0B-G00	–	8834-W1-000	K4U-A267AT	
PS10000R	1.25 NPT	1.5 NPT	F35-0B-C28	R40-0B-G00	L40-0B-G00	–	8834-W1-000	K4U-A267AT	
HA1 <sup>(2)</sup>	0.75 NPT	0.75 NPT	F28-06-SL00-28	R28-06-F0G0-28	L28-06-LK00-28	–	8846-W1-090	EU-A267	52104 / .75
HA2 <sup>(2)</sup>	1.0 NPT	1.0 NPT	F30-08-000	R30-08-000	L30-08-000	C31-08-G00	8848-W1-150	HU-A267AT	50592 / 1.25
LCA015S	0.5 BSP	0.75 NPT	F30-06-000	R30-06-000	L30-06-000	C31-06-G00	8846-W1-090	EU-A267	Built-in, internal muffling system
LCA030S	0.5 BSP	0.75 NPT	F30-06-000	R30-06-000	L30-06-000	C31-06-G00	8846-W1-090	EU-A267	
LCA060S/D	0.75 BSP	1.0 NPT	F30-08-000	R30-08-000	L30-08-000	C31-08-G00	8848-W1-150	EU-A267	
LCA120D	0.75 BSP	1.0 NPT	F30-08-000	R30-08-000	L30-08-000	C31-08-G00	8848-W1-150	EU-A267	
LCA180T	0.75 BSP	1.0 NPT	F30-08-000	R30-08-000	L30-08-000	C31-08-G00	8848-W1-150	EU-A267	
LCA250Q	0.75 BSP	1.0 NPT	F30-08-000	R30-08-000	L30-08-000	C31-08-G00	8848-W1-150	EU-A267	

1 Primary muffler for motor exhaust

2 Secondary muffler for valve exhaust:

FA2, FA2B, FA2.5, FA2.5A, FA5, FA5A, FA7 and FA10: Part number 52472 / 1.5 NPT

HA1 and HA2: Part number 52104 / 0.75 NPT

# Tech Tips

Technical support is an integral part of the Total System Solution philosophy that IR is dedicated to providing. The following pages contain useful technical information to assist in the selection of high capacity hoists and winches.

For regular updates and additions, please see our website at [www.airwinch.com](http://www.airwinch.com) for:

- *Drum Capacity Estimator* program: Plug in your numbers to determine the amount of wire rope a given size drum can hold.
- *Horizontal Load Reversing Capacity Estimator*: Calculates length of drum required to move a load a given distance.
- *Uplinks*: Technical discussions on various topics
- *Winch and hoist options*: Detailed descriptions and benefits of various options for IR hoists and winches
- *Seattle Specials*: Overviews and photos of engineered custom products not found in this catalog

### IR Drum Capacity Estimator

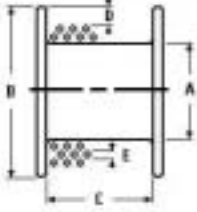

A Barrel diameter:  in

B Flange diameter:  in

C Drum length:  in

D **Freeboard:**  in

E Cable diameter:  English  Metric = inches

Unit of Measure  English  Metric     Drum surface  Smooth  Grooved

<a href="#">Total Drum Capacity:</a>	<input type="text"/> in
<a href="#">Total Working Drum Capacity:</a>	<input type="text"/> in
<a href="#">Recommended Working Capacity:</a>	<input type="text"/> in
<a href="#">D / d ratio:</a>	<input type="text"/>
<a href="#">Minimum distance to lead sheave:</a>	<input type="text"/> in
<a href="#">Maximum distance to lead sheave:</a>	<input type="text"/> in

[Wire Rope chart](#)  
[Definitions](#)

### IR Horizontal Load Reversing Capacity Estimator

Enter your choices for Barrel Diameter and Cable Size plus a value for either Drum Width or 1st Layer Travel, then click the Calculate button to determine the unknown value:

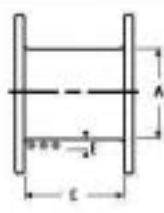

A Barrel diameter:  in

E Cable diameter:  English  Metric = inches

Unit of Measure  English  Metric

C Drum length:  in     Enter the value for one of these unknowns and click Calculate to generate the other value

[1st Layer Travel:](#)  in

[D / d ratio:](#)

[Minimum distance to lead sheave:](#)  in

[Wire Rope chart](#)  
[Dead Wraps](#)  
[What is HLR?](#)

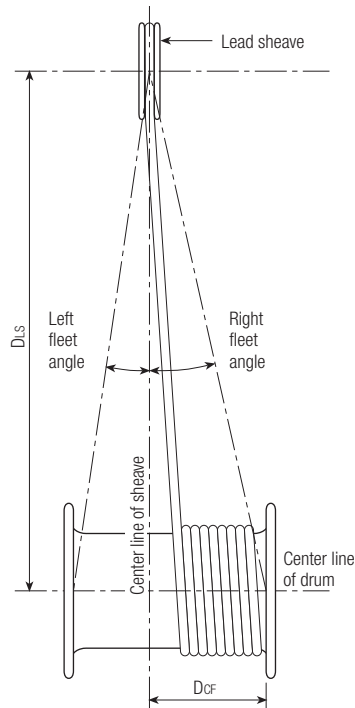

**The importance of fleet angle**

If a wire rope leads over a sheave and on to a drum, the rope will not remain in alignment with the sheave groove. Instead, it will deviate to either side depending upon the width of the drum and its distance from the fixed sheave, often called the lead sheave. The angle between the center line through the lead sheave and the centerline of the rope leading to the drum is called the fleet angle.

Experience has shown that the best wire rope service is obtained when the maximum fleet angle is not more than 1 1/2° for smooth drums, and 2° for grooved drums. Fleet angles of 1 1/2° and 2° are the equivalents of approximately 38 feet and 29 feet, respectively, of lead for each foot of drum width either side of the center line of the lead sheave.

Courtesy of Broderick & Bascom Rope Co.

Based on the above information, the correct distance (D<sub>LS</sub>) a lead sheave should be located from the winch drum may be derived by using the following formula:

$$D_{LS} \text{ for } 1\frac{1}{2}^\circ \text{ fleet angle} = D_{CF} \text{ (in feet)} \times 38 \quad D_{LS} \text{ for } 2^\circ \text{ fleet angle} = D_{CF} \text{ (in feet)} \times 29$$

**Example:** For a winch with a smooth drum thus requiring a 1 1/2° fleet angle:

If D<sub>CF</sub> = 20 inches (1.66 ft) then D<sub>LS</sub> = 1.66 x 38 = approximately 63 feet, the distance that the lead sheave should be positioned away from the drum.

**Determining stall and line pull**

Air pressure psi	bar	Stall factor	Rope speed factor
60	4.2	0.67	0.58
70	4.9	0.78	0.72
80	5.6	0.89	0.86
90	6.3	1.00	1.00
100	7.0	1.11	1.14

To obtain performances of the winches in this catalog at operating pressures other than 90 psi, select the load or speed rating required from the applicable curve and multiply that value by the factor corresponding to the operating pressure from the table.

**Example:** Model BU7A with 1000 lbs (455 kg) line pull, 70 psi (4.9 bar), drum half full. Determine speed.

From performance curve at 90 psi (6.3 bar): 22 fpm (6.7 m/min) x 0.72 (rope speed factor from chart above) = 16 fpm (4.9 m/min)

**Wire rope selection**

Rope size		Breaking strength		Weight		Rec'd safe working loads			
in.	mm	lbs	kg	lbs/ft	kg/m	3.5:1		5.:1	
						lbs	kg	lbs	kg
1/4	6	6800	3091	0.12	.17	1943	883	1360	618
5/16	8	10540	4791	0.18	.27	3011	1369	2108	958
3/8	9	15100	6864	0.26	.39	4314	1961	3020	1373
7/16	12	20400	9273	0.35	.52	5829	2649	4080	1855
1/2	13	26600	12091	0.46	.69	7600	3455	5320	2418
5/8	15	41200	18727	0.72	1.07	11771	5351	8240	3745
3/4	19	58800	26727	1.04	1.55	16800	7636	11760	5345
7/8	22	79600	36182	1.42	2.12	22743	10338	15920	7236
1	25	103400	47000	1.85	2.76	29543	13429	20680	9400
1 1/8	28	130000	59091	2.34	3.49	37143	16883	26000	11818
1 1/4	28	159800	72636	2.89	4.31	45657	20753	31960	14527
1 3/8	28	192000	87273	3.50	5.22	54857	24935	38400	17455

Ingersoll-Rand recommends that either 6 x 19 or 6 x 37 Extra Improved Plow Steel (EIPS) with independent wire rope core (IWRC) be used. This is a higher strength rope than Improved Plow Steel (IPS) offering, on average, approximately a 15% increase in breaking strength. We recommend it, as it is readily available and offers better value overall.

**Spark and corrosion resistant equipment: The S•COR•E series product line is intended to provide improved levels of corrosion and spark-resistant protection for manual, pneumatic and electric powered hoists and trolleys, with capacities available from 1/2 to 50 tons.**

The S•COR•E series of options provides for improved protection, durability and performance for hoist operations in corrosive or harsh environments.

It is generally accepted that rusty, and/or corroded steel is more likely to generate sparks than if free from corrosion or rust. Therefore, any improvement in corrosion or rust-resistance results in improved spark-resistance.

A spark of sufficient heat to ignite the surrounding atmosphere generally is unlikely in mechanical hoisting equipment, but it may potentially be generated by friction during operation or unintentional impact of a hoist or trolley with other metal components. In order to provide the user with corrosion and spark-resistance protection,

IR offers different levels of protection from which you can select to fit your particular needs.

**The user is cautioned to check carefully the local and/or national standards, codes, etc. which may affect the selection and use of equipment in the intended environment.**

**Nickel diffused load chain<sup>(1)</sup> – designed specifically for corrosive and potentially harsh environments.**

The manufacturer of the nickel-diffused chain advises us that compared with steel, stainless steel, alloy steel, and copper steel, (under like test conditions) ND chain produced fewer sparks. ND chain is our selection for use on S•COR•E products in the sizes available versus stainless steel, because the ND chain does not lose strength

during the nickel-diffusing process. Additionally, the ND chain has a harder surface and greater corrosion and flaking resistance than the softer chains.

Eventually, both ND chain and most stainless steel chains will have corrosion and, perhaps, some rust. The user should therefore regularly examine the load chain for the appearance of corrosion and rust, which indicates the termination of its spark resistant life, and the chain should be replaced immediately.

**Copper plating, zinc plating, solid bronze**

Various institutes and standards organizations have studied the corrosion and spark-resistant nature of metals. Most manufacturers, including IR, will offer products that are resistant to corrosion and sparking, but are not to be considered spark-proof. This is essentially because most metals, including zinc, bronze, and stainless steel, will spark from the application of sufficient striking force and energy.

S•COR•E series products use plated or solid, non-ferrous metals to provide "spark-resistance" by reducing the likelihood of corrosion and sparking, and also the temperature of the spark, if one should occur.

Ultimately, the selection of the correct corrosion and spark-resistant features is the responsibility of the customer.

**Plated and "solid bronze" hoist and trolley components**

Third party research provides overwhelming evidence that non-ferrous metals and substances offer excellent anti-sparking characteristics. Their use meets or exceeds all known requirements for protection against spark generation in a hydrocarbon environment.

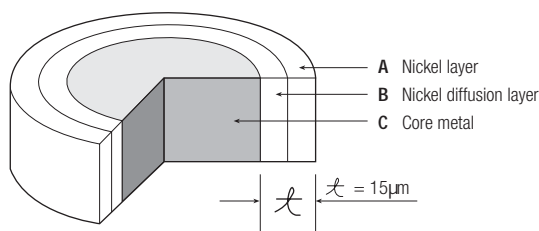

Nickel diffused load chain

Please note: National Electric Code [NEC] and the National Electrical Manufacturers Association [NEMA] have established classes and divisions of hazardous environments for electrical components and equipment. The NEC and NEMA standards do not apply to the mechanical properties of equipment that electric motors may be mounted on.)

**Warning:** Before installation see maintenance and operations manual for additional warnings and precautions. This equipment is not to be used for lifting, supporting or transporting people, or lifting or supporting loads over people.

(1) Nickel diffused load chain is only available on Ingersoll-Rand manual chain hoist products.

The following table shows the standard size (H dimension), flange widths (W dimensions) and weights for both American Standard I-beams and Wide Flange H-beams. I-beams designated with an asterisk (\*) denote New Series applications which conform to ASTM A6 standards, effective September 1, 1978.

Wide Flange									American Standard		
H in.	W in.	Weight per ft/lbs	H in.	W in.	Weight per ft/lbs	H in.	W in.	Weight per ft/lbs	H in.	W in.	Weight per ft/lbs
6	3.940	8.5	10	10.117	66.0	16*	6.985	36	4	2.663	7.7
6*	4.0	9.0	10*	10.130	68.0	16	7.0	40	4	2.796	9.5
6	4.0	12.0	10	10.170	72.0	16*	6.995	40	5	3.004	10.0
6*	4.0	12.0	10	10.190	77.0	16	7.039	45	5	3.284	14.75
6	4.030	16.0	10*	10.190	77.0	16*	7.035	45	6	3.332	12.5
6*	4.030	16.0	10*	10.625	88.0	16	7.073	50	6	3.565	17.25
6*	5.990	15.0	10	10.275	89.0	16*	7.070	50	7	3.662	15.3
6	5.995	15.5	10	10.340	100.0	16*	7.120	57	7	3.860	20.0
6	6.020	20.0	10*	10.340	100.0	16	8.464	58	8	4.001	18.4
6*	6.018	20.0	10	10.415	112.0	16*	10.235	67	8	4.171	23.0
6	6.080	25.0	10*	10.415	112.0	16*	10.295	77	10	4.661	25.4
6*	6.080	25.0	12	3.968	14.0	16*	10.365	89	10	4.944	35.0
8	3.940	10.0	12*	3.970	14.0	16*	10.425	100	12	5.0	31.8
8*	3.940	10.0	12*	3.990	16.0	16	11.502	88	12	5.078	35.0
8	4.0	13.0	12	4.0	16.5	16	11.5	96	12	5.252	40.8
8*	4.0	13.0	12	4.005	19.0	18	6.0	35	12	5.477	50.0
8	4.015	15.0	12*	4.007	19.0	18*	6.0	35	15	5.501	42.9
8*	4.015	15.0	12	4.030	22.0	18	6.015	40	15	5.640	50.0
8	5.250	17.0	12*	4.030	22.0	18*	6.015	40	18	6.001	54.7
8*	5.250	18.0	12*	6.490	26.0	18*	6.060	46	18	6.251	70.0
8	5.268	20.0	12	6.497	27.0	18	7.477	45	20	6.25	65.4
8*	5.270	21.0	12*	6.520	30.0	18	7.5	50	20	6.385	75.0
8	6.495	24.0	12	6.525	31.0	18*	7.5	50	20	7.060	86.0
8*	6.5	24.0	12*	6.560	35.0	18	7.532	55	20	7.200	96.0
8	6.535	28.0	12	6.565	36.0	18*	7.530	55	24	7.001	79.9
8*	6.535	28.0	12	8.0	40.0	18	7.558	60	24	7.125	90.0
8	7.995	31.0	12*	8.005	40.0	18*	7.555	60	24	7.245	100.0
8*	7.995	31.0	12	8.042	45.0	18*	7.635	71	24	7.875	105.9
8	8.020	35.0	12*	8.045	45.0	18	8.715	64	24	8.050	121.0
8*	8.020	35.0	12	8.077	50.0	18	8.75	70			
8	8.070	40.0	12*	8.080	50.0	18	8.787	77			
8*	8.070	40.0	12	10.0	53.0	18*	11.035	76			
8	8.110	48.0	12*	9.995	53.0	18*	11.090	86			
8*	8.110	48.0	12	10.014	58.0	18*	11.145	97			
8	8.220	58.0	12*	10.010	58.0	18*	11.200	106			
8*	8.220	58.0	14	5.0	22.0	18*	11.265	119			
8	8.280	67.0	14*	5.0	22.0	18	11.75	96			
8*	8.280	67.0	14	5.025	26.0	21	6.5	44			
10	3.950	11.5	14*	5.025	26.0	21*	6.5	44			
10*	3.960	12.0	14	6.730	30.0	21*	6.530	50			
10	4.0	15.0	14*	6.730	30.0	21*	6.555	57			
10*	4.0	15.0	14	6.75	34.0	21	8.215	55			
10	4.010	17.0	14*	6.745	34.0	21	8.240	62			
10*	4.010	17.0	14	6.770	38.0	21*	8.240	62			
10	4.020	19.0	14*	6.770	38.0	21	8.270	68			
10*	4.020	19.0	14	8.0	43.0	21*	8.270	68			
10	5.75	21.0	14*	7.995	43.0	21	8.295	73			
10*	5.75	22.0	14	8.031	48.0	21*	8.295	73			
10	5.762	25.0	14*	8.030	48.0	21*	8.355	83			
10*	5.770	26.0	14	8.062	53.0	21*	8.420	93			
10	5.799	29.0	14*	8.060	53.0	21	8.962	82			
10*	5.810	30.0	14	10.0	61.0	24	7.005	55			
10	7.960	33.0	14*	9.995	61.0	24*	7.005	55			
10*	7.960	33.0	14	10.035	68.0	24*	7.040	62			
10	7.985	39.0	14	10.035	68.0	24	8.961	68			
10*	7.985	39.0	14	10.072	74.0	24*	8.965	68			
10	8.020	45.0	14*	10.070	74.0	24	8.965	76			
10*	8.020	45.0	14	12.0	78.0	24*	8.990	76			
10	10.0	49.0	14	14.5	87.0	24	9.015	84			
10*	10.0	49.0	14*	10.130	82.0	24*	9.020	84			
10	10.030	54.0	16	5.5	26.0	24	9.065	94			
10*	10.030	54.0	16	5.525	31.0	24*	9.065	94			
10	10.080	60.0	16*	5.525	31.0	-	-	-			
10*	10.080	60.0	16	6.692	36.0	-	-	-			

American Standard

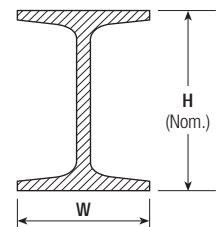

Tapered "I" Beam

Wide Flange

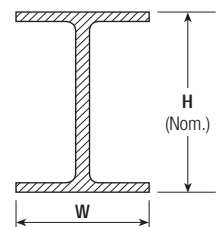

Flat "H" Beam

### Explanation of metric units

The kilogram (kg) is a unit of mass. Mass is the property of matter which determines its inertia. The mass of a body never varies and is independent of gravitational force.

The newton (N) is a unit of force. The first law of motion, force is equal to mass times acceleration, defines the newton in terms of base units.  $1 \text{ N} = 1 \text{ kg} \cdot \text{m/s}^2$

The joule (J) is a unit of energy and is the work done when a force of one newton is displaced a distance of one meter in the direction of the force.  $1 \text{ J} = \text{N} \cdot \text{m}$

The watt (W) is a unit of power which produces energy at the rate of one joule per second.  $1 \text{ W} = \text{J/s}$

The pascal (Pa) is a unit for pressure or stress of one newton per square meter.  $1 \text{ Pa} = 1 \text{ N/m}^2$

The kelvin (K) is the unit for Thermodynamic Temperature and is the preferred unit to express temperature and temperature intervals. However, it is permissible to use the Celsius scale where considered necessary. The temperature interval one degree Celsius equals one kelvin exactly.

### Length

To convert US measure	multiply by	to obtain metric measure
Inches (in.)	25.4	millimeters (mm)
Inches (in.)	2.54	centimeters (cm)
Inches (in.)	0.0254	meters (m)
Feet (ft)	304.8	millimeters (mm)
Feet (ft)	30.48	centimeters (cm)
Feet (ft)	0.3048	meters (m)
Yards (yd)	0.9144	meters (m)

### Area

Square inches (in <sup>2</sup> )	645.16	square millimeters (mm <sup>2</sup> )
Square inches (in <sup>2</sup> )	6.4516	square centimeters (cm <sup>2</sup> )
Square feet (ft <sup>2</sup> )	929.03	square centimeters (cm <sup>2</sup> )
Square yards (yd <sup>2</sup> )	0.836	square meters (m <sup>2</sup> )

### Volume

Cubic inches (in <sup>3</sup> )	16.39	cubic centimeters (cm <sup>3</sup> )
Cubic feet (ft <sup>3</sup> )	0.02832	cubic meters (m <sup>3</sup> )
Cubic yards (yd <sup>3</sup> )	0.7646	cubic meters (m <sup>3</sup> )
Fluid ounces (fl oz)	29.57	milliliters (mL)
US quarts (qt)	0.946	liters (L)
US gallons (gal)	3.785	liters (L)
US gallons (gal)	0.003785	cubic meters (m <sup>3</sup> )

### Mass

Ounces (oz)	28.35	grams (g)
Pounds (lbs)	453.6	grams (g)
Pounds (lbs)	0.4536	kilograms (kg)
Pounds (lbs)	0.00045	metric tons (t)
US tons (T)	907.18	kilograms (kg)
US tons (T)	0.9072	metric tons (t)

### Force

Pounds (lbs)	4.4448	Newtons (N)
Pounds (lbs)	0.0044	kilonewtons (kN)
Foot pounds (ft-lbs)	1.3557	Newton meters (Nm)

### Flow rate

To convert US measure	multiply by	to obtain metric measure
Cubic feet per minute (cfm)	0.02832	cubic meters per minute (m <sup>3</sup> /min)
Cubic feet per minute (cfm)	1.699	cubic meters per hour (m <sup>3</sup> /h)
Cubic feet per hour (cfh)	0.02832	cubic meters per hour (m <sup>3</sup> /h)
Feet per minute (fpm)	0.3048	meters per minute (m/min)
Pounds per minute (lb/m)	0.4536	kilograms per minute (kg/min)

### Pressure stress

Pounds per square inch (psi)	6.895	kilopascals (kPa)
Pounds per square inch (psi)	0.0007	kilograms per square millimeter (kg/mm <sup>2</sup> )
Pounds per square inch (psi)	0.07	bar
Foot pounds per square inch (lbf/in <sup>2</sup> )	0.006895	megapascals (mPa)
Bars	100	kilopascals (kPa)

### Energy work

Foot pounds per foot	1.356	joules (J)
Calories	4.187	joules (J)
Btus	1.055	kilojoules (kJ)
Kilowatt hours	3.6	megajoules (MJ)

### Power

Btus per hour (Btu/h)	0.2931	watts (W)
Btus per second (Btu/s)	1.055	kilowatts (kW)
Ft lbs per ft/min (ft lbf/min)	0.0226	watts (W)
Horsepower (hp)	0.7457	kilowatts (kW)

### Temperature

Degrees Fahrenheit	$1.8 + 32$	degrees Celsius
Degrees Kelvin	degrees Celsius + 273.15	

# IR Winch Check List

Fax to the FASTeam, Seattle at 206-624-6265; call 206-624-0466 or email to: FASTeam@irco.com

This form should accompany all winch inquiries. Use of this check list will help minimize changes after the order has been entered.

Distributor \_\_\_\_\_ End user \_\_\_\_\_

Contact name \_\_\_\_\_ Contact name \_\_\_\_\_

Fax/phone no. \_\_\_\_\_ Fax/phone no. \_\_\_\_\_

Reference no. (order/inquiry/bid) \_\_\_\_\_ Reference no. (order/inquiry/bid) \_\_\_\_\_

General description/model or application requirements (please describe in detail the application and provide a sketch or drawing if possible). \_\_\_\_\_  
\_\_\_\_\_  
\_\_\_\_\_

Quantity \_\_\_\_\_

### Power source:

Manual \_\_\_\_\_

Air (pressure, flow) \_\_\_\_\_

Electric (cycles, phase, voltage) \_\_\_\_\_

Hydraulic (pressure, flow) \_\_\_\_\_

Lifting or pulling application \_\_\_\_\_ How far/how high \_\_\_\_\_

Selected winch capacity \_\_\_\_\_ Winch speed? \_\_\_\_\_ fpm

Speed at mid-drum, top or first wrap layer? \_\_\_\_\_ fpm

Drum storage \_\_\_\_\_ Rope diameter \_\_\_\_\_ in./min

Duty cycle (if known) \_\_\_\_\_ Environment \_\_\_\_\_

Time required to complete lift or pull (speed) \_\_\_\_\_ fpm

Control type (local, remote, electrical voltage. Include maximum distance.) \_\_\_\_\_

Special standards or documents required? \_\_\_\_\_ Name/no. \_\_\_\_\_

Special paint/color/coating? \_\_\_\_\_ Details \_\_\_\_\_

Special manufacturing requirements? \_\_\_\_\_ QA/QC \_\_\_\_\_

### Options:

Brakes Manual \_\_\_\_\_ Auto \_\_\_\_\_ Band \_\_\_\_\_

Disc \_\_\_\_\_ Special \_\_\_\_\_

Drum Standard \_\_\_\_\_ Other length \_\_\_\_\_ Flange \_\_\_\_\_

Grooving \_\_\_\_\_ Divider flange \_\_\_\_\_

Drum guard \_\_\_\_\_ (fixed/movable)

Air line equipment (FRL's, muffler, tension manifold) \_\_\_\_\_

Other options \_\_\_\_\_  
\_\_\_\_\_  
\_\_\_\_\_

Attach additional sheets if required and sketches if possible

# IR Hoist Check List

Fax to the FASTeam, Seattle at 206-624-6265; call 206-624-0466 or email to: FASTeam@irco.com

This form should accompany all hoist inquiries. Use of this check list will help minimize changes after the order has been entered.

Distributor \_\_\_\_\_ End user \_\_\_\_\_  
Contact name \_\_\_\_\_ Contact name \_\_\_\_\_  
Fax/phone no. \_\_\_\_\_ Fax/phone no. \_\_\_\_\_  
Reference no. (order/inquiry/bid) \_\_\_\_\_ Reference no. (order/inquiry/bid) \_\_\_\_\_

General description/model or application requirements (please describe in detail the application and provide a sketch or drawing if possible). \_\_\_\_\_  
\_\_\_\_\_  
\_\_\_\_\_

Quantity \_\_\_\_\_

### Power source:

- Manual \_\_\_\_\_
- Air (pressure, flow) \_\_\_\_\_
- Electric (cycles, phase, voltage) \_\_\_\_\_
- Hydraulic (pressure, flow) \_\_\_\_\_

Capacity \_\_\_\_\_ Headroom requirements \_\_\_\_\_

Lift \_\_\_\_\_ feet (This is the distance the hook must travel.)

Hoist lifting speed \_\_\_\_\_ fpm Special chain \_\_\_\_\_

Control length \_\_\_\_\_ feet Chain bucket?  yes  no

For air pendent, standard or pilot? \_\_\_\_\_ Or Accu-trol? \_\_\_\_\_

Duty cycle (if known) \_\_\_\_\_ Electrical protection \_\_\_\_\_

Environment \_\_\_\_\_ Overload device \_\_\_\_\_

Type and number of brakes \_\_\_\_\_

Suspension (lug, trolley, hook, other) \_\_\_\_\_

Beam size/type, flange width \_\_\_\_\_ If power trolley – speed required \_\_\_\_\_ fpm

For power trolley, power cord length \_\_\_\_\_ feet

Does control need to be combined with hoist control? \_\_\_\_\_

Special standards or documents required? \_\_\_\_\_ Name/no. \_\_\_\_\_

Special paint/color/coating? \_\_\_\_\_ Details \_\_\_\_\_

Special manufacturing requirements? \_\_\_\_\_ QA/QC \_\_\_\_\_

Accessories (limit switches, FRL's, Travel-Air, hoses, etc.) \_\_\_\_\_  
\_\_\_\_\_  
\_\_\_\_\_  
\_\_\_\_\_  
\_\_\_\_\_

Attach additional sheets if required and sketches if possible







## ***Winch and High Capacity Hoist Limited Warranty***



IR warrants to the original user its Winches and High Capacity Hoists (Products) to be free of defects in material and workmanship for a period of one year from the date of purchase. IR will repair, without cost, any Product found to be defective, including parts and labor charges, or at its option, will replace such Products or refund the purchase price less a reasonable allowance for depreciation, in exchange for the Product. Repairs or replacements are warranted for the remainder of the original warranty period.

If any Product proves defective within its original one year warranty period, it should be returned to any Authorized Hoist and Winch Service Distributor, transportation prepaid with proof of purchase or warranty card.

This warranty does not apply to Products which IR has determined to have been misused or abused, improperly maintained by the purchaser; or where the malfunction or defect can be attributed to the use of non-genuine IR parts.

IR makes no other warranty, and all implied warranties including any warranty of merchantability or fitness for a particular purpose are limited to the duration of the expressed warranty period as set forth above. IR's maximum liability is limited to the purchase price of the Product and in no event shall IR be liable for any consequential, indirect, incidental, or special damages of any nature arising from the sale or use of the Product, whether based on contract, tort, or otherwise.

Note: Some states do not allow limitations on incidental or consequential damages or how long an implied warranty lasts so that the above limitations may not apply to you. This warranty gives you specific legal rights and you may also have other rights which may vary from state to state.

Office and distributors in principal cities throughout the world. Contact the nearest Ingersoll-Rand office for the name and address of the distributor in your country or write to: Ingersoll-Rand, P.O. Box 24046 Seattle, WA 98124-0046 USA

### United States Regional Sales Offices

#### For Order Entry and Order Status:

##### Ingersoll-Rand Distribution Center

510 Hester Drive, P.O. Box 618, White House, TN 37188  
Phone: (615) 672-0321 Fax: (615) 672-0801

#### For Technical Support:

##### Ingersoll-Rand Material Handling FasTeam

2724 Sixth Avenue South, P.O. Box 24046, Seattle, WA 98124  
Phone: (206) 624-0466 Fax: (206) 624-6265  
Toll Free: (866) 273-3278  
Email: FASTeam@irco.com

### International

#### National Sales Office Regional Warehouse Toronto, Ontario

51 Worcester Road, Rexdale, Ontario M9W 4K2  
Phone: (416) 213-4500 Fax: (416) 213-4510  
Order Desk – Fax: (416) 213-4506

#### Ingersoll-Rand SEA Pte. Ltd.

42 Benoi Road, Jurong, Singapore 629903  
Phone: (65) 6861 1555 Fax: (65) 6862 1373

#### Canadian Regional Sales Offices

##### British Columbia

1200 Cliveden Avenue, Delta B.C. V3M 6G4  
Phone: (604) 523-0803 Fax: (604) 523-0801

##### Montreal, Quebec

3501 St. Charles Blvd., Suite 104, Kirkland, Quebec H9H 4S3  
Phone: (514) 695-9040 Fax: (514) 695-0963

#### Russia Ingersoll-Rand Co.

Presnensky Val, 19, Moscow, Russia 123557  
Phone: (7) 095-933-03-24 Fax: (7) 095-737-01-48  
Phone: (7) 095-933-03-21

#### Australia Ingersoll-Rand Ltd.

Landmark Corporate Centre  
Level 2, 454-472 Nepean Highway, Frankston, Vic. Australia 3199  
Phone: (61) 3 8781 1600 Fax: (61) 3 8781 1611

#### Latin America Operations

##### Ingersoll-Rand Production Equipment Group

730 N.W. 107 Avenue, Suite 300, Miami, Florida 33172-3107  
Phone: (305) 559-0500 Fax: (305) 222-0864

#### Europe, Middle East and Africa

##### Ingersoll-Rand Material Handling – Douai Operations

111, avenue Roger Salengro, 59450 SIN LE NOBLE, France  
Phone: (33) 3-27-93-08-08 Fax: (33) 3-27-93-08-00



**WARNING:** This equipment is not designed for transporting people or lifting loads over people. It is the user's responsibility to determine the suitability of this product for any particular use and to check compliance with applicable regulations. Before installation, see maintenance and operations manual for additional warnings and precautions.

Call 1-800-IR HOIST (474-6478) for the distributor nearest you.

Visit our web site at: [www.airwinch.com](http://www.airwinch.com)

© 2003 Ingersoll-Rand Company

Form No. MHD55199/010103 Printed in U.S.A./30M



FM 53539

